

## IPT-HD 50/70/95mm<sup>2</sup> ISO CABLE

### APPLICATION SPECIFICATION

(High current screwed connector sealed)

### IPT-HD 50/70/95mm<sup>2</sup> ISO 线缆产品应用规范书



				PR: K.SI DATE:23Marth2022	 TE Connectivity Shanghai, China		
B2	Revise	H.W	23APR2023				
B	Revise	C.Z	02JUN2023	CHK: J.LI DATE: 23Marth2022			
A1	Revise	C.C	22MAY2022				
A	Initial Released	K.SI	14MAR2022	APP: Z.W. ZHOU DATE: 23Marth2022	Document No.: 114-160263	LOC: ES	REV:B2
LTR	REVISION RECORD	PR	DATE				



## CONTENT 目录

1. SCOPE 适用范围 .....	3
1.1 Content 内容 .....	3
1.2 Processing notes 加工说明 .....	3
2. APPLICABLE DOCUMENTS 适用文件 .....	3
2.1 TE Connectivity Documents 泰科电子文件 .....	3
2.1.1 Customer drawings 客户图纸 .....	3
2.1.2 Specifications 规范 .....	4
2.2 General Documentation 通用文档 .....	4
2.2.1 Cable Specification 线缆规格 .....	4
3. CONDITION OF DELIVERY AND PACKAGING 交货和包装状态 .....	5
3.1 Components 零部件 .....	5
3.2 Packaging and Storage 包装和贮存 .....	7
4. APPLICATION TOOLS 应用工装 .....	7
4.1 Ring tongue application tool 端子应用工装 .....	8
4.2 Shielding crimp 屏蔽压接 .....	8
5. ASSEMBLY INSTRUCTIONS 组装说明 .....	8
5.1 Overview of all parts should be assembled 全部部件总览图 .....	9
5.2 Shielding Wire assembly process 屏蔽组装制程 .....	10
5.3 Mounting instructions for the IPT-HD 安装说明 .....	14
5.4 Mounting Dimension illustration 安装尺寸说明 .....	15
5.5 Dismounting instructions for the IPT-HD 产品拆卸说明 .....	16
6. FINAL EXAMINATION 终检 .....	16
6.1 Visual Examination 外观检查 .....	16
6.2 Electrical Tests 电气测试 .....	16
6.2.1 On-line electrical test 在线测试 .....	17
7. APPENDIX 附录 .....	17
7.1 ISO HUBER SUHNER 50/70/95mm <sup>2</sup> .....	17



- ◆ This connector is intended for use in high-voltage applications. Special care must be applied to ensure that the connector functions as intended.
- ◆ If you suspect that the connector has been modified, damaged, contaminated or other wise compromised, please discontinue its use immediately.
- ◆ This connector should only be serviced by a trained and qualified technician.

## 1. SCOPE 适用范围

### 1.1 Content 内容

This specification covers the requirements for application of the sealed IPT-HD 50/70/95 mm<sup>2</sup> High Voltage connector. The IPT-HD connector system is designed to meet LV215-2 specifications. The connector incorporates conductive EMI shielding to reduce radiated emissions in the application. The housings are molded in orange to denote a high voltage system.

该规范涵盖了密封IPT-HD 50/70/95 mm<sup>2</sup> 高压连接器的应用要求。IPT-HD连接器系统的设计符合LV215-2规范。该连接器采用导电EMI屏蔽，以减少应用中的辐射。外壳采用橙色模制，表示高压系统。

### 1.2 Processing notes 加工说明

The processor is responsible for ensuring the quality of the manufacturing process and the proper function of the system. The warranty and liability is excluded, if quality deficiency or damages occurs by failing compliance to this specification or using not specified, not released tools or not released connector components.

加工者负责确保制造过程的质量和系统的正常功能。如果由于未遵守本规范或使用未定义的、未发布的工装或未发布的连接器组件而导致质量异常或损坏，则不承担保修和责任。

## 2. APPLICABLE DOCUMENTS 适用文件

The following mentioned documents are part of this specification. If there is a conflict between the information contained in the documents and this specification or with any other technical documentation supplied, the last valid customer drawings takes preference.

以下提到的文件是本说明书的一部分。如果文档中包含的信息与本规范或提供的任何其他技术文档之间存在冲突，则最新有效的客户图纸优先。

### 2.1 TE Connectivity Documents 泰科电子文件

This Application Specification based on the latest valid customer drawings.  
本应用规范基于最新的有效客户图纸。

#### 2.1.1 Customer drawings 客户图纸



Drawing No./ Component Description List	
C-2371019	1pos Ring Tongue, Housing, Assy, Sealed
C-2371017	2pos Ring Tongue, Housing, Assy, Sealed
C-2355146	3pos Ring Tongue, Housing, Assy, Sealed
C-2355153	Protective cover
C-2355148	Shielding sleeve
C-2355150	Shielding
C-2355151	Single wire seal
C-2177380	50mm <sup>2</sup> wire Ring tongue
C-2365737	70 mm <sup>2</sup> & 95mm <sup>2</sup> wire Ring tongue

Table 1: Customer drawings

### 2.1.2 Specifications 规范

Specifications	Description
108-160480	IPT HD 50/70/95mm <sup>2</sup> ISO CABLE SPECIFICATION
114-160263	IPT HD 50/70/95mm <sup>2</sup> ISO CABLE APPLICATION SPECIFICATION

Table 2: TE-specifications

## 2.2 General Documentation 通用文档

### 2.2.1 Cable Specification 线缆规格

Cable specifications of tested high voltage (HV)cables, shielded

Supplier: ISO Huber Suhner (Part No.: 84096257 /50mm<sup>2</sup> )

Cross-section: 50mm<sup>2</sup>

Core diameter: Max. 9.4mm

Outer diameter: 14.9+/-0.3

Supplier: ISO Huber Suhner (Part No.: 84100298 /70mm<sup>2</sup>)  
 Cross-section: 70mm<sup>2</sup>  
 Core diameter: Max. 11.6mm  
 Outer diameter: 17.0+/-0.3

Supplier: ISO Huber Suhner (Part No.: 84100299 /95mm<sup>2</sup>)  
 Cross-section: 95mm<sup>2</sup>  
 Core diameter: Max. 13.5mm  
 Outer diameter: 19.9+/-0.4

If the wires listed cannot meet your requirements, please contact with the responsible TE Connectivity employees.  
 如果上面列出的线缆不能满足你的需求，请联系TE的负责人员。

### 3. CONDITION OF DELIVERY AND PACKAGING 交货和包装状态

#### 3.1 Components 零部件







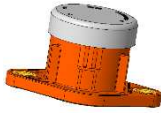

Description 描述	Picture for ref. 图片	Usage 用量	PN for 95mm <sup>2</sup> 95 平方线部件号	PN for 70mm <sup>2</sup> 70 平方线部件号	PN for 50mm <sup>2</sup> 50 平方线部件号
1pos Ring Tongue, Housing Assy with dust cover		1	2371019-1		
1pos Ring Tongue, Housing Assy		1	2371019-2		
Protective cover		1	2355153-6	2355153-3	2355153-4
Shielding sleeve		1	2355148-5	2355148-1	2355148-3
Shielding		1	2355150-8 plating Sn	2355150-2 plating Sn	2355150-4 plating Sn
Single wire seal		1	2355151-3	2355151-1	2355151-2
Ring tongue		1	2365737-2	2365737-1	3-2177380-1
heat-shrinkable tubing		N/A	5039254029		

Table 3: required components for assembly of IPT-HD 1POS

Description 描述	Picture for ref. 图片	Usage 用量	PN for 95mm <sup>2</sup> 95 平方线部件号	PN for 70mm <sup>2</sup> 70 平方线部件号	PN for 50mm <sup>2</sup> 50 平方线部件号
2pos Ring Tongue, Housing Assy with dust cover		1	2371017-1		
2pos Ring Tongue, Housing Assy		1	2371017-2		
Protective cover		2	2355153-6	2355153-3	2355153-4
Shielding sleeve		2	2355148-5	2355148-1	2355148-3
Shielding		2	2355150-8 plating Sn	2355150-2 plating Sn	2355150-4 plating Sn
Single wire seal		2	2355151-3	2355151-1	2355151-2
Ring tongue		2	2365737-2	2365737-1	3-2177380-1
heat-shrinkable tubing		N/A	5039254029		

Table 4: required components for assembly of IPT-HD 2POS

Description 描述	Picture for ref. 图片	Usage 用量	PN for 95mm <sup>2</sup> 95 平方线部件号	PN for 70mm <sup>2</sup> 70 平方线部件号	PN for 50mm <sup>2</sup> 50 平方线部件号
3pos Ring Tongue, Housing Assy with dust cover		1	2355146-1		
3pos Ring Tongue, Housing Assy		1	2355146-2		
Protective cover		3	2355153-6	2355153-3	2355153-4
Shielding sleeve		3	2355148-5	2355148-1	2355148-3
Shielding		3	2355150-8 plating Sn	2355150-2 plating Sn	2355150-4 plating Sn
Single wire seal		3	2355151-3	2355151-1	2355151-2
Ring tongue		3	2365737-2	2365737-1	3-2177380-1
heat-shrinkable tubing		N/A	5039254029		

Table 5: required components for assembly of IPT-HD 3POS

### 3.2 Packaging and Storage 包装和贮存

The products should be used on a “first in, first out” basis to avoid storage contamination, please refer to the latest valid customer drawings.

为避免存储污染，产品应以“先进先出”的原则使用，请参见最新的有效客户图纸。

### 4. APPLICATION TOOLS 应用工装

The Application tools are only valid for the specified cables at appendix. More tooling information can be obtained through a local TE Representative, or calling the product information Center after purchase.

应用工装仅对附录中的指定电缆有效。可通过当地TE代表获取更多工装信息，或者在购买后，拨打产品信息中心电话。

#### 4.1 ring tongue application tools 端子应用工装

<b>Application tools / 应用工装</b>	
2359763-1	Ring Tongue, IPT-HD 70mm <sup>2</sup> crimp tool
528041-7	Ring Tongue, IPT-HD 50mm <sup>2</sup> crimp tool
2383674-1	Ring Tongue, IPT-HD 95mm <sup>2</sup> crimp tool

Table 6: application tools contact crimp

#### 4.2 Shielding crimp 屏蔽压接

The following table contains the required order numbers for application tools.  
下表包含所需应用工装的订货号。

<b>Application tools / 应用工装</b>	
2410072-1	Shield crimp tool for 70mm <sup>2</sup> ISO cable
2410071-1	Shield crimp tool for 50mm <sup>2</sup> ISO cable
2396869-1	Shield crimp tool for 95mm <sup>2</sup> ISO cable

Table 7: Application tools

### 5. ASSEMBLY INSTRUCTIONS 组装说明

The following procedures show the details of the cable assembly and insertion instructions of the cable assembly into the plug housing subassembly. The processing is only valid for the specified cable at appendix and only these combinations have been validated by TE. Alternative cables may be used after ensuring performance through validation testing.

下述步骤显示了线缆组件的细节和线缆组件插入母端壳体子组件的插入说明。该制程仅对附录中的指定线缆有效，并且仅这样的组合通过TE验证。在通过验证测试性能之后，可以使用替代电缆。



## 5.1 Overview of all parts should be assembled 全部部件总览图

Component of IPT-HD 1P 50mm<sup>2</sup> &70mm<sup>2</sup> &95 mm<sup>2</sup> review

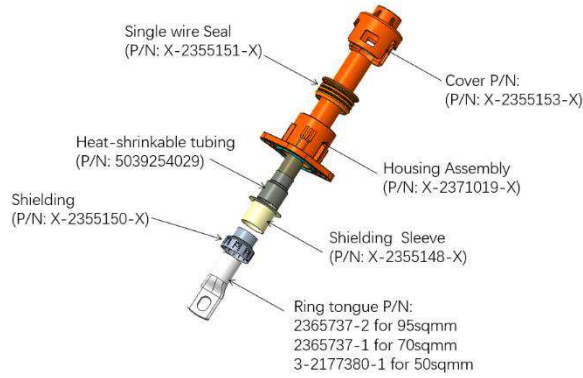

Figure 1: explosion view

Component of IPT-HD 2P 50mm<sup>2</sup> &70mm<sup>2</sup> &95 mm<sup>2</sup> review

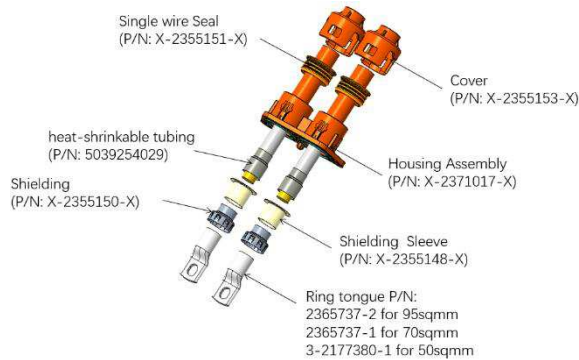

Figure 2: explosion view

Component of IPT-HD 3P 50mm<sup>2</sup> &70mm<sup>2</sup> &95 mm<sup>2</sup> review

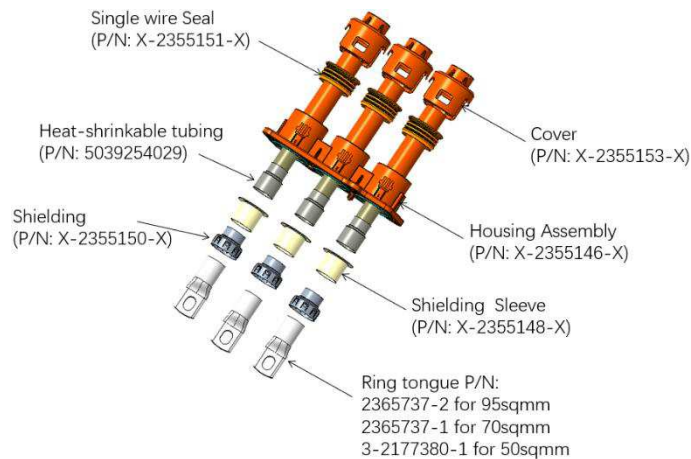

Figure 3: explosion view

## 5.2 Shielding Wire assembly process 屏蔽组装制程

Safety alerts, continus or repeated contact with conductor and shielding is not allowed, protective gloves should be worn if necessary.

安全提醒，请勿长时间或重复与导体或屏蔽接触，必要时请穿戴防护手套。

Step 1/步骤一 In the order shown in figure 4, slide cover, single wire seal and shield sleeve onto cable sheath, keeping them out of crimping area.

按照图4所示的顺序，滑动保护盖，线缆密封圈和屏蔽套管到电缆护套上，使它们不在压接区域。

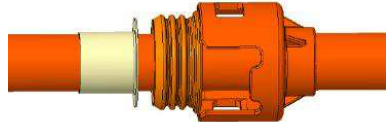

Figure 4: slide components onto cable before processing

Step 2/步骤二 Strip and remove outer sheath, screening braid (if present screening foil), inner sheath and conductor from the end as shown in figure 5.

Stripping dimensions for exposing wire as shown in table 7

如图5所示，切开并去除外绝缘皮，屏蔽编织物（如果存在屏蔽箔），内绝缘皮和导体。

剥线尺寸如表7所示

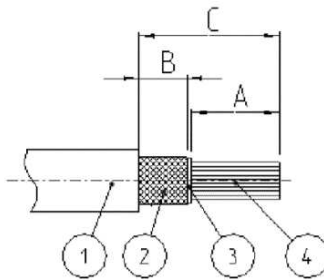

Figure 5: cutting cable to length



Attention: Cable sheath and shielding braid shall not be cut or broken during the cutting procedure.

注意：切割过程中不得切割或破坏电缆护套和屏蔽编织层。

1000VDC 70mm <sup>2</sup>					
(ID)	Cable Design	A [mm]	B [mm]	C [mm]	C-A [mm]
1	Outer sheath	--	--	48±1	
2	Screening braid	--	(8)	--	
3	Inner sheath	--	--	--	(27)
4	Conductor	21±1	--	--	

Table 8: Cutting dimensions for 70mm<sup>2</sup>

1000VDC 50mm <sup>2</sup>					
(ID)	Cable Design	A [mm]	B [mm]	C [mm]	C-A [mm]
1	Outer sheath	--	--	47±1	
2	Screening braid	--	(8)	--	
3	Inner sheath	--	--	--	(31)
4	Conductor	16±1	--	--	

Table 9: Cutting dimensions for 50mm<sup>2</sup>

1000VDC 95mm <sup>2</sup>					
(ID)	Cable Design	A [mm]	B [mm]	C [mm]	C-A [mm]
1	Outer sheath	--	--	53±1	
2	Screening braid	--	(8)	--	
3	Inner sheath	--	--	--	(29)
4	Conductor	24±1	--	--	

Table10: Cutting dimensions for 95mm<sup>2</sup>

Step 3/步骤三 Assemble shielding 组装屏蔽环



Figure 6: Assemble shielding

Step 4/步骤四 Assemble the ring tongue and crimp it.  
Dimension between the tongue and the outer sheath shall be below 1mm  
组装并压接端子  
端子与外皮间的距离需小于1mm



Figure 7: Crimp the ring tongue

Wire size	CH	CB	
50mm <sup>2</sup>	7.3+/-0.10	14.60Max.	
70mm <sup>2</sup>	10.55+/-0.10	16.45Max.	
95mm <sup>2</sup>	12.2+/-0.1	20 Max.	

Table 11: ring tongue crimping height

Step 5/步骤5 Raise and smooth screening braid over shielding ferrule.  
翻起和捋平蔽丝的覆盖在屏蔽环上

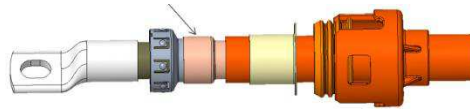

Figure 8: raise and smooth screening braid

Step 6/步骤6 Push shielding sleeve ahead, screening braid should be covered.  
组装屏蔽套筒覆盖编织线



Figure 9: assemble shielding sleeve

Step 7/步骤7 Crimp shielding 压接屏蔽环  
As shown in figure 10, adjust the position of shielding according to table 12 then crimp the shielding.  
如图10所示，依据表格12调整屏蔽位置进行压接。

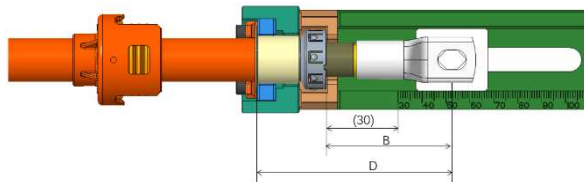

Figure 10: location of shielding

Shielding to Ring tongue Minimum distance for 1000VDC		
TYPE	DIM.B	DIM.D
50 mm <sup>2</sup>	49.4	78.6
70 mm <sup>2</sup>	52.4	81.6
95 mm <sup>2</sup>	62.4	91.6

Table 12: shielding to ring tongue distance

 It is essential that there are no mistakes in this step because there will be no chance to re-work the parts.  
在这一步中没有错误是至关重要的，因为无法重新加工。

The following items at minimum must be inspected and verified, before and after shield crimp process.

- All components are present, and parts are crimped in correct orientation and location
- No visible cracking of the shielding parts and no loose cable shield strands
- Shielding crimp dimensions per to table 13
- Excess length of screening braid must be visible max. 1mm
- Allocation of screening braid should be equal over perimeter
- After shielding crimp, flange deformation should not exceed 2mm (refer to Fig 12)

在屏蔽压接前后，必须至少检查并验证以下项目：

- 所有部件完整，部件以正确的方向和位置进行压接
- 屏蔽部件没有明显的开裂，也没有松散的电缆屏蔽线
- 屏蔽压接按照表13
- 屏蔽编织的长度必须可见最大1毫米
- 屏蔽编织应该均匀分配在四周
- 压接后，法兰盘变形不能超过2mm（参照图12）

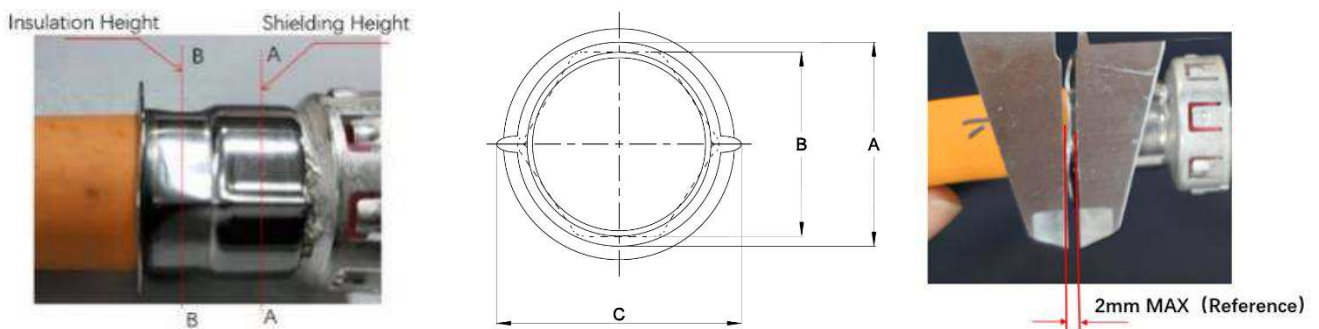

Figure 12: round crimp for shielding and hex crimp for insulation crimp

Dimension confirm after crimping				
H+S	50mm <sup>2</sup>	16.80 ± 0.1	16.70 ± 0.15	24 Max.
H+S	70mm <sup>2</sup>	19.0 ± 0.1	18.90 ± 0.15	24 Max.
H+S	95mm <sup>2</sup>	21.8 ± 0.1	20.45 ± 0.1	25.5 Max.
Supplier	Size	Shielding Height A	Insulation Height B	Shielding Width C

Table 13: crimping height of shielding

Step 8/步骤8 Cover the gap with heat shrink tube, heat for seal, recommend distance to be 34mm, heat shrink tube refer to TE Part NO. : 5039254029

用热缩套管覆盖间隙，加热密封，推荐长度为34mm，热缩套管参考泰科零件号：5039254029

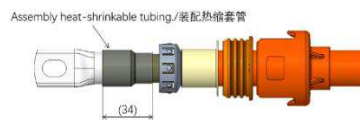

Figure 13: heating seal heat-shrinkable tubing

## 5.3 Mounting instructions for the IPT-HD 安装说明

Step 1/步骤1 Assemble housing assembly to system with M6 bolts, tightening torque recommended to be  $8.0 \pm 1\text{Nm}$   
用M6的螺钉将塑壳装配到系统面板上，安装扭矩推荐为 $8.0 \pm 1\text{Nm}$

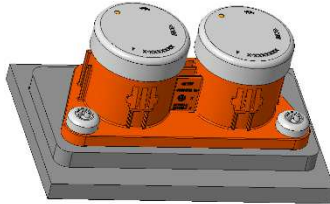

Figure 14: assemble housing assembly

Step 2/步骤2 Remove the cover.  
将盖子取下。

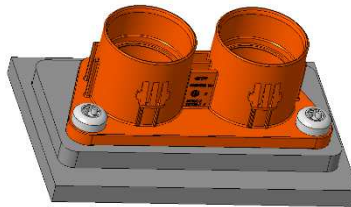

Figure 15: remove the cover

Attention: Some slight traces may appear when removing the cover, these traces won't affect the function.  
注意：在去除盖子的过程中，塑胶的外侧可能会出现一些轻微的划痕，这些划痕不会影响产品功能。

Step 3/步骤3 Plug harness into the housing assembly  
将线束插入到塑胶内

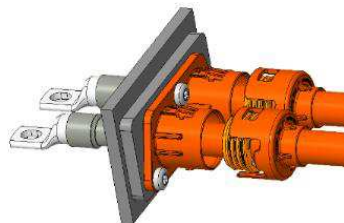

Figure 16: assemble the harness

Step 4/步骤4 Push the cover ahead and lock it on the housing assembly.  
向前推盖子并将它锁在塑胶外壳上。

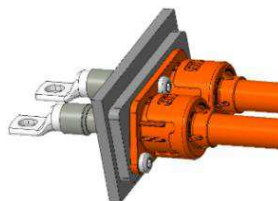

Figure 17: lock housing cover

Step 5/步骤5 Fix each ring tongue and diecasting with a bolt of M8, tightening torque recommended to be  $15 \pm 1.5\text{Nm}$

每个端子与汇流排都用一颗M8的螺栓连接。推荐扭矩为15+/-1.5Nm

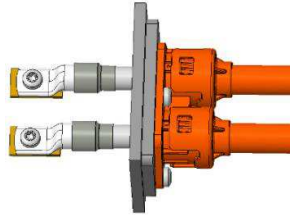

Figure 18: screw the ring tongue to the busbar

## 5.4 Mounting Dimension illustration 安装尺寸说明

D: Distance between center of Ring tongue and shielding flange 端子中心到屏蔽法兰环距离

E: Distance between center of Ring tongue and diecasting surface 端子中心到应用面板距离

F: Diecasting Minimum thickness requirement 应用界面的最小厚度要求

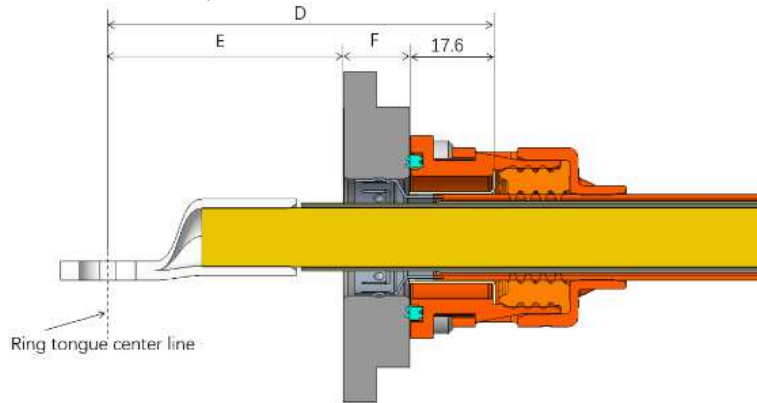

Figure 19: mounting Dimension illustration

WIRE CROSS SECTION	Application 1000VDC		
	DIM.D Min	DIM.E	DIM.F Min
50mm <sup>2</sup>	78.6	47	14Min
70mm <sup>2</sup>	81.6	50	14Min
95mm <sup>2</sup>	91.6	60	14Min

Table 14: Mounting Dimension

Note:

1. Dimension E in the table 14 was determined by Min. creepage distance and Min. clearance according to DIN EN 60664-1: Max. altitude of 5500M, pollution degree II, Maximum Voltage 1000VDC, dielectric strength 4000VAC  
表格14中E尺寸取决最小爬电距离和电气间隙要求：依照DIN EN 60664-1：最大海拔高度5500m，污染等级II，最大电压1000VDC，耐电压4000VAC

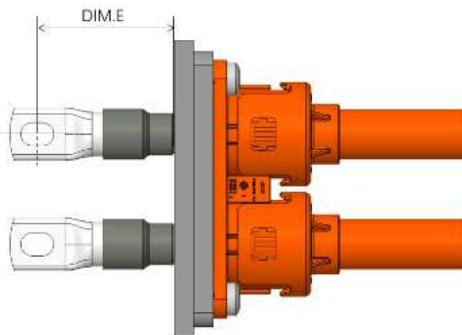

Figure 20: 1000VDC electrical distance requirement

2. DIM. F must meet Minimum thickness requirement: 14mm 尺寸F面板厚度必须满足最小14mm

3. DIM.D determined by DIM.E and DIM.F 尺寸D是由尺寸E和尺寸F决定

For example, under the requirement of 1000VDC, 4000VAC and degree of pollution 2, DIM.E must be 50mm Min. for 70mm<sup>2</sup> cable because of the limit of electrical clearance and creepage.

例如, 在1000VDC, 4000VAC, 污染等级为2的要求下, 由于爬电距离和电气间隙的限制, 70平线缆的尺寸E必须满足最小50mm

DIM E: 50

DIM F: 14

DIM D= E+F+17.6=50+14+17.6=81.6



If Voltage 1000VDC and interface thickness of 14mm cannot meet your application, please contact with the responsible TE Connectivity employees. Cable assemble dimension will be adjusted and recommended again.

如果最大电压1000VDC和板厚14mm不能满足你的应用,请联系TE工作人员重新推荐压接线束的尺寸。

## 5.5 Dismounting instructions for the IPT-HD 产品拆卸说明

Step 1/步骤1 Dismount Ring tongue and busbar with special tool  
用专用工具将端子和busbar铜排连接拆卸

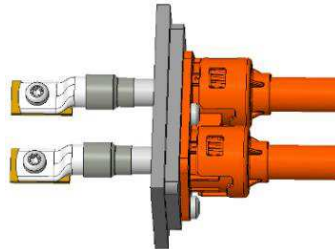

Figure 21: dismount Ring tongue

Step 2/步骤2 Dismount the M6 bolts then remove the whole assembly  
拧下M6螺栓后将整个组件移除

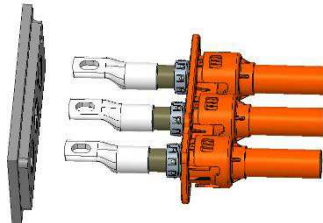

Figure 22: remove plug assembly

## 6. FINAL EXAMINATION 终检

### 6.1 Visual Examination 外观检查

After processing the connector assembly has to be checked of completeness, correctness acc. customer drawings and free of damage.

在装配连接器后, 必须根据客户图纸进行完整性、正确性检查, 且不能损坏。

### 6.2 Electrical Tests 电气测试

Electrical characteristic values according product specification TE-108-160480 / chapter 3.4 are ensured by applicator. The test parameter should be not exceeding the values shown in point 3.4.

使用方依据产品规范TE-108-160480第3.4章保证电气特性。测试参数不应超出规范3.4章的值。



## 6.2.1 On-line electrical test 在线测试

Apply 4000VAC to the online samples for 60s , record the leakage current. Leakage current  $\leq 10$  mA.  
施加4000VAC 60s 测试在线样品，记录电流泄漏量不超过10mA

## 7. APPENDIX 附录

### 7.1 ISO HUBER SUHNER 50 to 95mm<sup>2</sup>

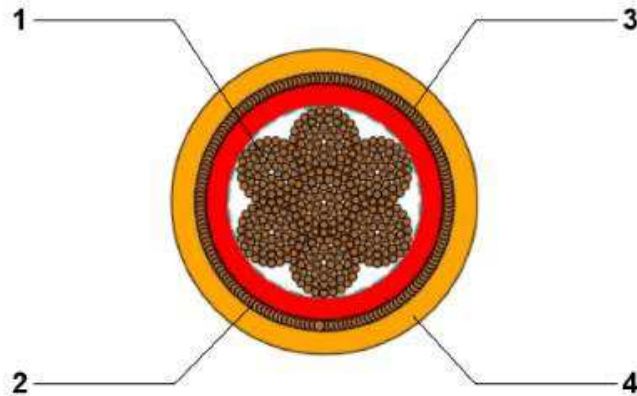

1. 1 Core 50 mm<sup>2</sup>

2. EMC-screen optimized  
3. Wrapping  
4. Sheath

Conductor: stranded bare copper  
Insulation: RADOX 155  
Colours: red  
Tin plated copper braid  
Tape  
RADOX Elastomer S  
Colour: orange

385 x 0.41 mm D  
D: 11.50 ± 0.25 mm  
D: 12.7 mm  
D: 14.9 ± 0.3 mm

Figure 23: ISO HUBER SUHNER 50mm<sup>2</sup> Part No: 84096257

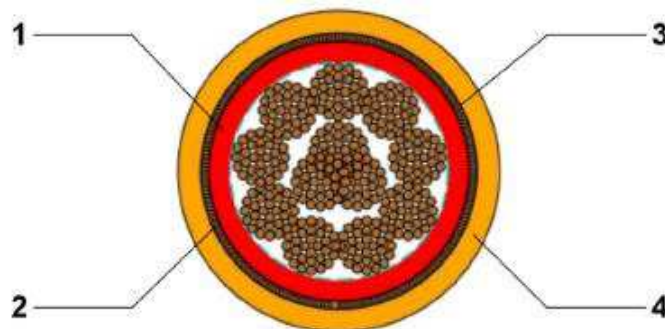

1. 1 Core 70 mm<sup>2</sup>

2. EMC-screen optimized  
3. Wrapping  
4. Sheath

Conductor: stranded bare copper  
Insulation: RADOX 155  
Colour: red  
Tin plated copper braid  
Tape  
RADOX Elastomer S  
Colour: orange

360 x 0.51 mm D  
D: 13.70 ± 0.25 mm  
D: 14.6 mm  
D: 17.0 ± 0.3 mm

Figure 24: ISO HUBER SUHNER 70mm<sup>2</sup> Part No: 84100298

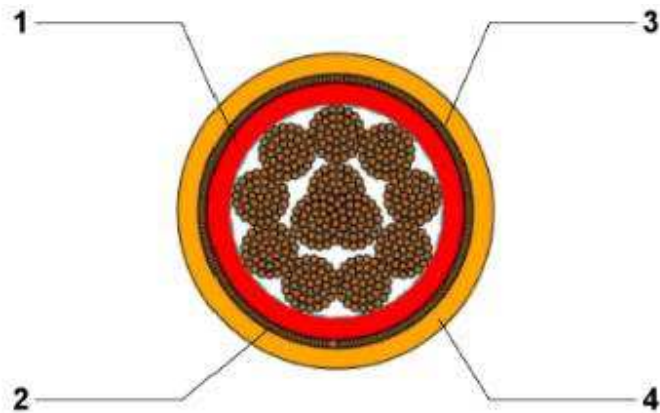

- 1. 1 Core 95 mm<sup>2</sup>
- 2. EMC-screen optimized
- 3. Wrapping
- 4. Sheath

Conductor: stranded bare copper  
 Insulation: RADOX 155  
 Colour: red  
 Tin plated copper braid  
 Tape  
 RADOX Elastomer S  
 Colour: orange

480 x 0.51 mm D  
 D: 16.25 ± 0.30 mm  
 D: 17.4 mm  
 D: 19.9 ± 0.4 mm

Figure 25: ISO HUBER SUHNER 95mm<sup>2</sup> part No: 84100299