Application Specification for JPT/Tab 2.8mm housings, 2 to 24 poles
(For Adam Opel AG and their suppliers only)

Contents

1 Introduction

1.1 Product Description - Description of the Components

1.1.1 Product Description - Flat-Contact Housing

1.1.2 Product Description - Tab Housing

1.2 Product Numbers and Codes

2 TE Specifications

3 Assembly

3.1 Delivery State

3.2 Loading the Housing with Contacts

3.3 Fitting the Second Contact Retainer

3.4 Fitting the Gasket in the Tab Housing

3.5 Mounting the Tab Housing in the Hole

3.6 Pulling and Pushing the Slide in the Flat-Contact Housing

3.7 Closing the Flat-Contact and Tab Housings

3.7.1 Closing the Flat-Contact and Tab Housings with the
Slide in the Final Locking Position

3.7.2 Closing the Flat-Contact and Tab Housings with the
Slide in the Pre-Locking Position

3.8 Opening the Flat-Contact and Tab Housings

3.9 Removing the Tab Housing from the Panel Cut Out

3.10.1 Removing the Secondary Locking Device from the Receptacle Housing

3.10.2 Removing the Secondary Locking Device from the Tab Housing

3.11 Removing the seal from the Tab Housing

3.12 Removing Contacts from the Housing

1 Introduction

This application specification describes the procedures, typical possible faults and special features for loading waterproof flat-contact housings and tab housings with Junior Power Timer contacts and 2.8 mm tabs, respectively, and the second contact retainer, and also the mating and opening of the two halves of the connector.

1.1 Product Description - Description of the Components

A complete connector contains the following components.

1.1.1 Product Description - Flat-Contact Housing

- 1) Flat-contact housing for Junior Power Timer contact
- 2) Slide for flat-contact housing pos. (1) and pos. (2) already assembled and are available only as a complete assembly.
- 3) 2nd contact retainer for flat-contact housing

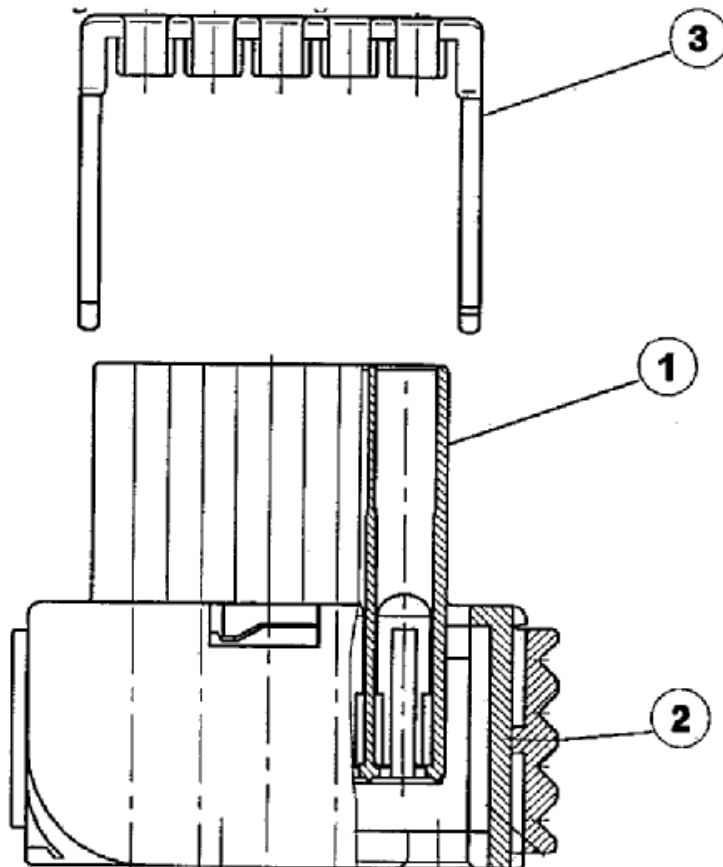

1.1.2 Product Description - Tab Housing

- 1) Tab housing for 2.8 mm tabs
- 2) Gasket for tab housing
- 3) 2nd contact retainer for tab housing

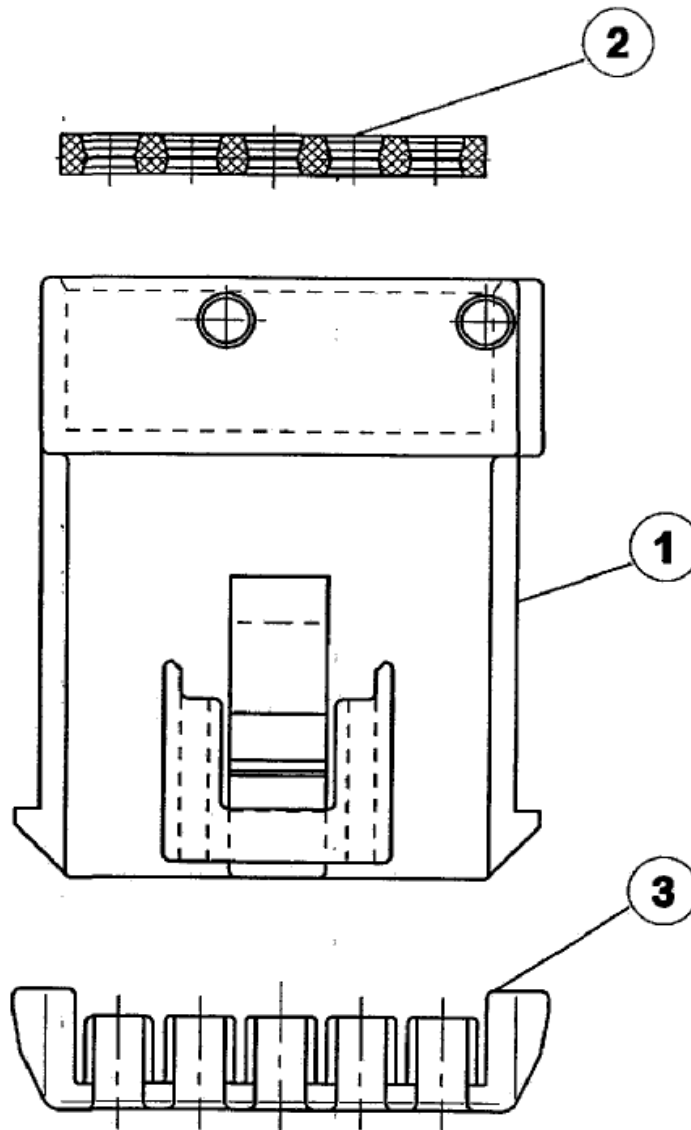

1.2 Product Numbers and Codes

The following table provides an overview of the parts to be used. Any specifications in the TE product drawings have priority. The drawings also specify the color and keying variants and show the Part Nos.

Number of posns.(design)	Flat-contact housing	Matching 2nd contact retainer	Tab housing	Matching 2nd contact retainer	Gasket
2posn.	963210	-----	962344	-----	963209
4posn.	929033	929031	965261	-----	963208
6posn.	963212	964713	962349	-----	963205
6posn. in prelocking position	967554	964713	962349	-----	963205
6posn.	1355696	964713	962349	-----	963205
10posn.	963214	964692	962352	964693	963213
10posn. in prelocking position	967556	964692	962352	964693	963213
10posn.	967324	964692	962352	964693	963213
10posn. in prelocking position	967555	964692	962352	964693	963213
12posn.	966399	964456	964695	964455	963216
12posn. in prelocking position	967557	964456	964695	964455	963216
13posn. in prelocking position	967564	964456	968677	964455	963216
16posn.	963217	964456	964449	964455	963216
24posn.	966500	964740	964739	964740	964741
24posn. in prelocking position	967558	964740	964739	964740	964741

Note: slide in pre-locking position means that the slide cannot be slid into the housing without being released manually.

2 TE Specifications

The TE specifications listed in the related product specifications of the individual parts are the basis for and a component part of this application specification and apply accordingly.

3 Assembly

3.1 Delivery State

Depending on the Part No., the slide on flat-contact housings is delivered in either the final locking position (Fig. 1) or the pre-locking position (Fig. 2).

Fig. 1:

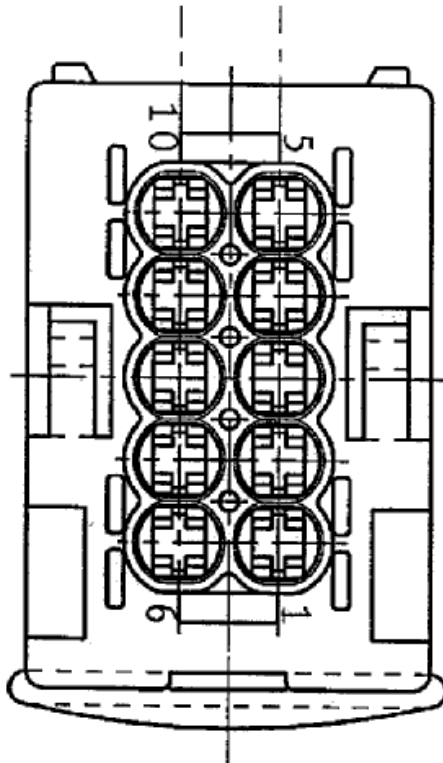
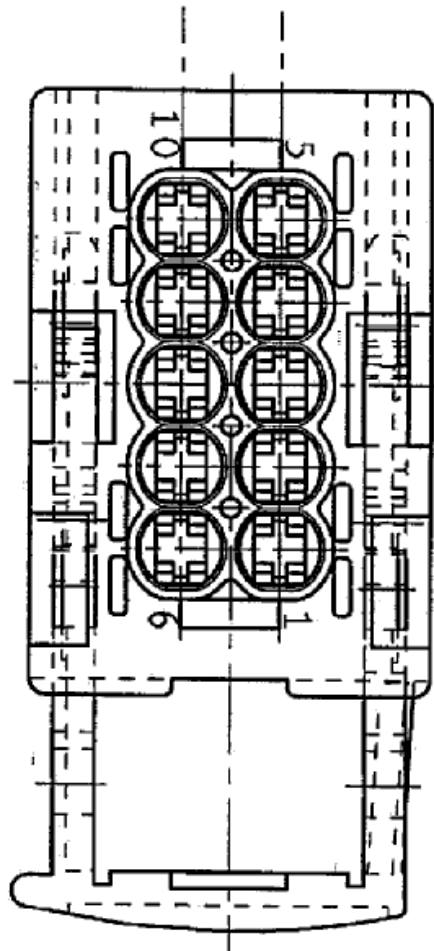

Fig. 2:



3.2 Loading the Housing with Contacts

The housings must be loaded as follows with contacts in accordance with the TE product specification / TE customer drawing (see figure 3,4). Any cavities in which no contacts are installed must always be filled with dead-end plugs PN: 828906-2 in order to seal them and prevent the entry of water.

Fig.3:

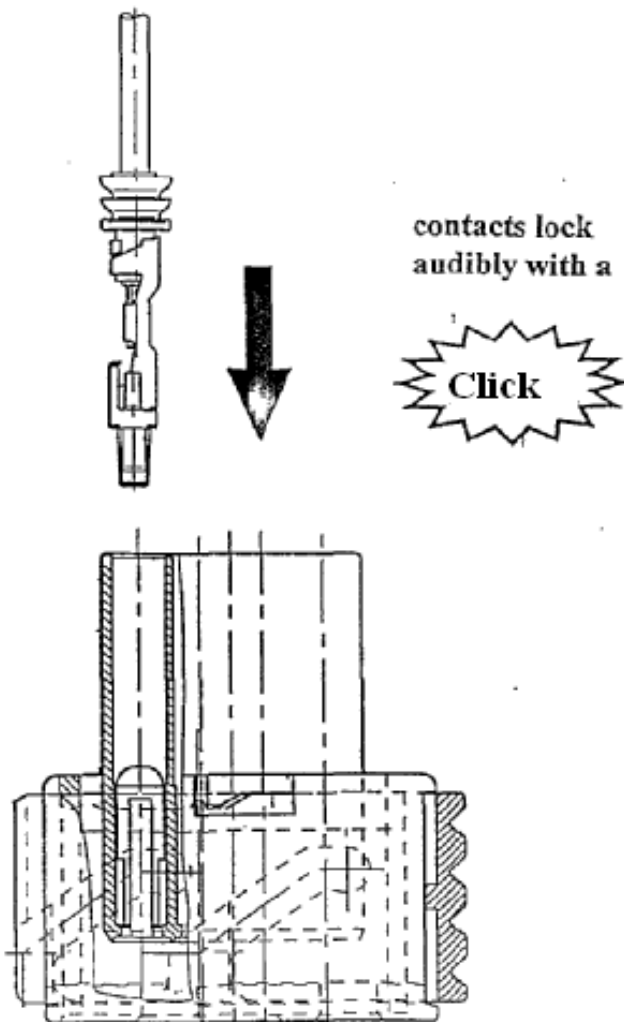
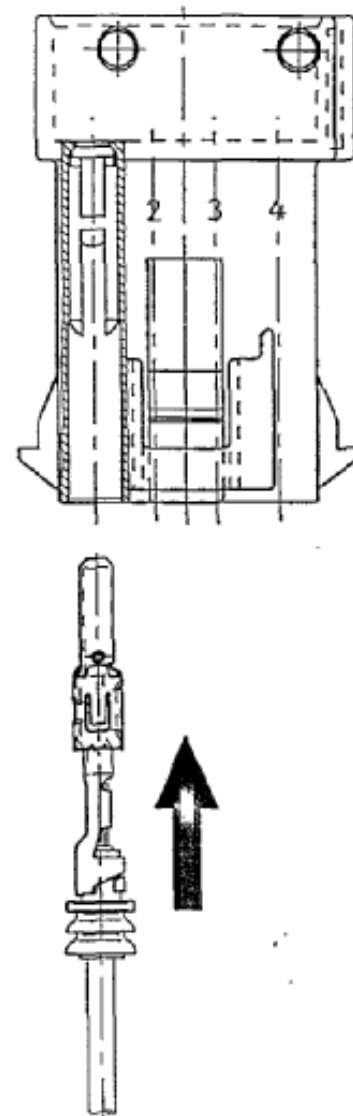

Fig.4:



3.3 Fitting the Second Contact Retainer

If a second contact retainer is provided for the housing, this must always be fitted. Whether or not a second contact retainer is provided is indicated in the TE customer drawing, which contains the appropriate notes.

The second contact retainer is fitted as shown in Fig. 5 (for the flat-contact housing) and Fig. 6 (for the tab housing). The contact retainer is slid between the wires and clipped to the plastic part.

Fig.5:

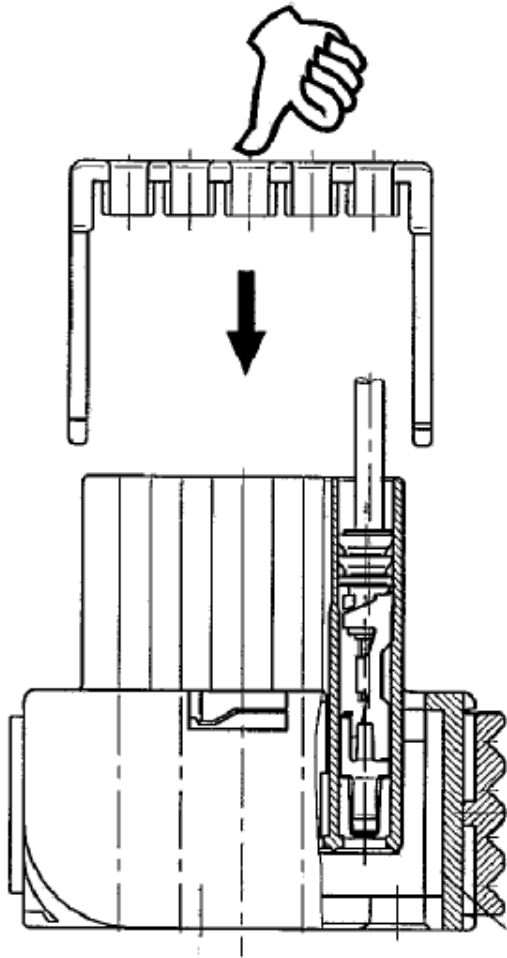
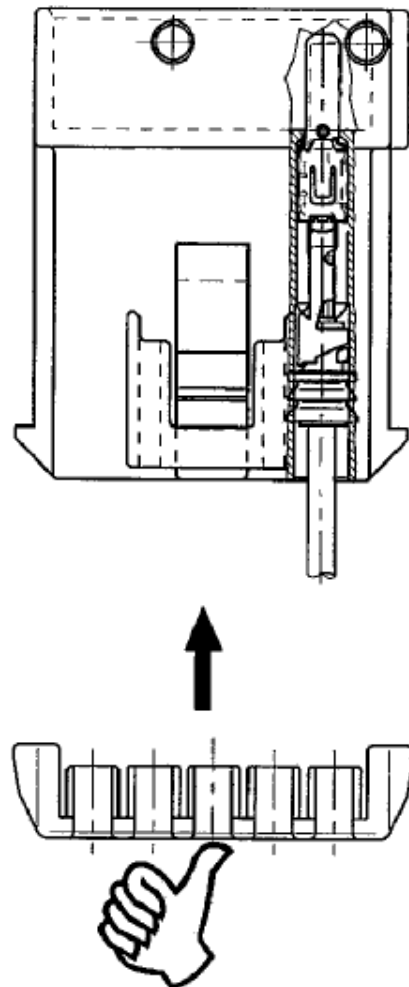

Fig.6:



3.4 Fitting the Gasket in the Tab Housing

After the housing has been loaded with 2.8 tabs, the gasket must be pressed into the collar of the housing (Fig. 7). As this is done, the tabs penetrate the thin skins of the gasket. The gasket must be pressed down to the bottom of the collar (Fig. 8).

Fig. 7:

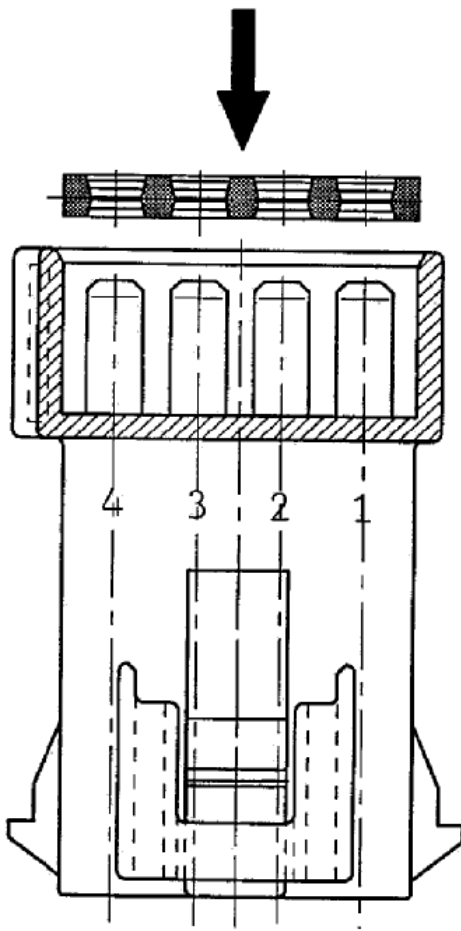
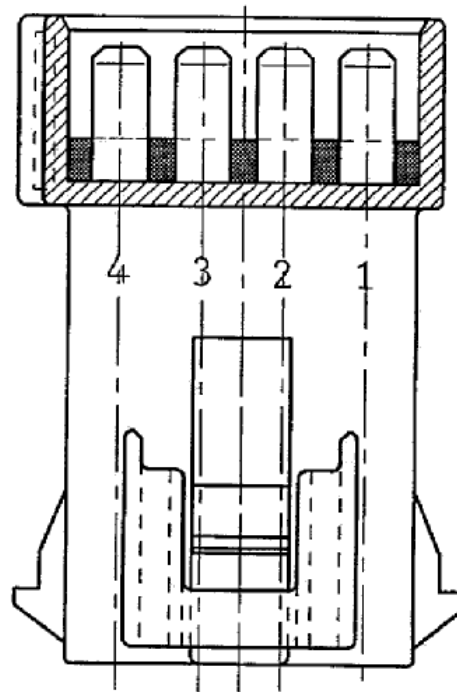

Fig. 8:



3.5 Mounting the Tab Housing in the Hole

The tab housing must be inserted from the top into the hole in the sheet metal and clipped in position (Fig. 9). For this, the two locking latches of the tab housing must be free to move under pressure (Fig. 10). The hole in the sheet metal for insertion of the housing is shown in the TE customer drawing.

TE guarantees correct operation only for the holes cut in accordance with the TE customer drawings. Other mounting methods are not the responsibility of TE and TE accepts no responsibility for correct operation.

Fig. 9:

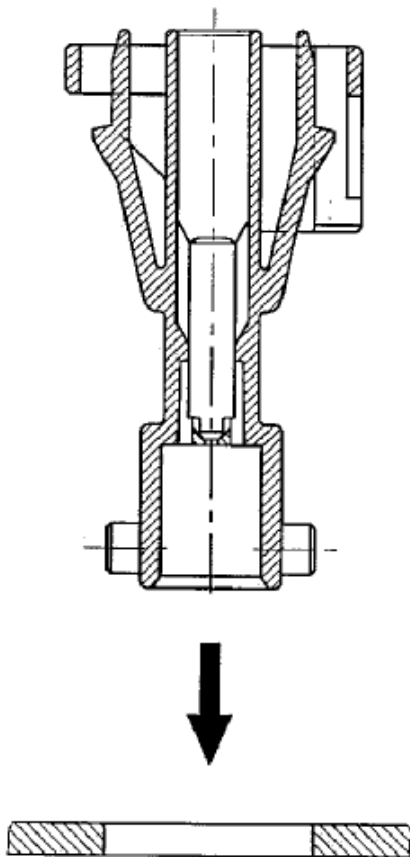
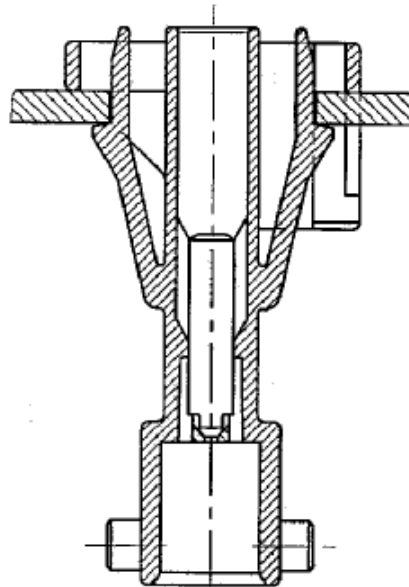

Fig. 10:



3.6 Pulling and Pushing the Slide in the Flat-Contact Housing

The slide is designed for parallel actuation and must be operated accordingly. Tilting or tipping of the slide will increase the required actuating force.

Fig. 11a:

Parallel: OK

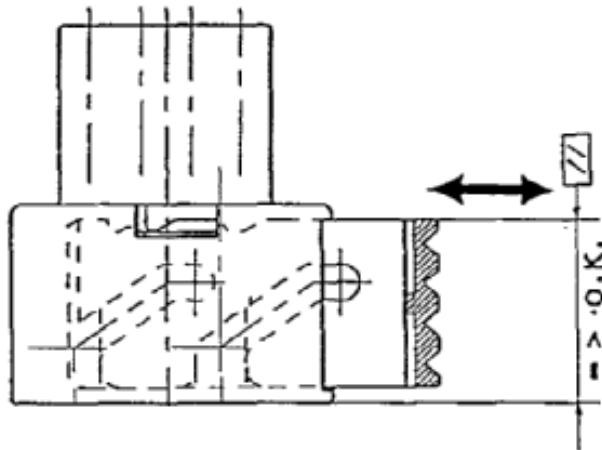

Fig. 11b:

**Tilted downwards:
not OK**

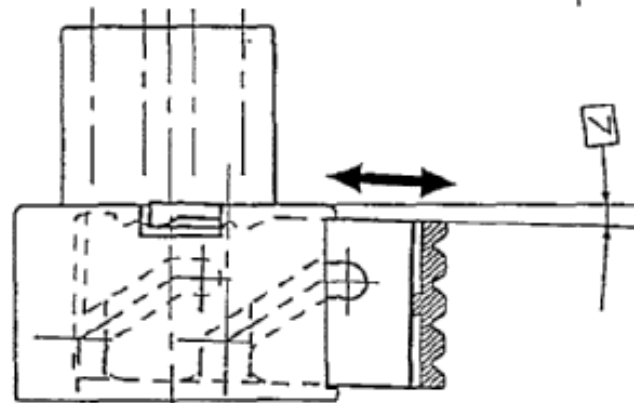
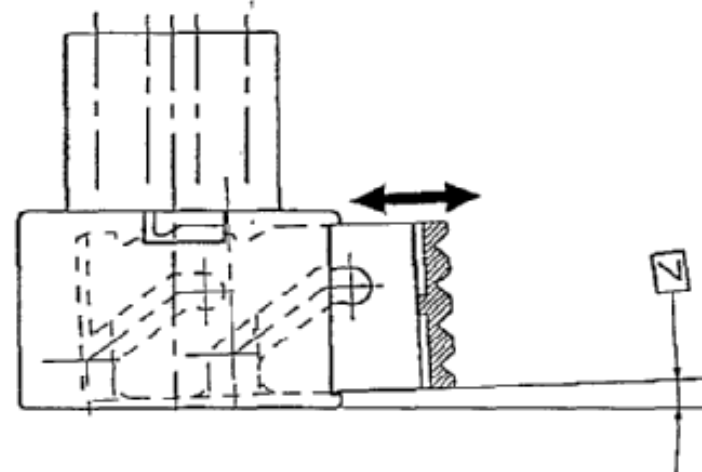

Fig. 11c:

**Tilted upwards:
not OK**



3.7 Closing the Flat-Contact and Tab Housings

For this, a distinction must be made between two design principles, namely housings supplied with the housing slide in the final-locking position and in the pre-locking position.

3.7.1 Closing the Flat-Contact and Tab Housings with the Slide in the Final Locking Position

The slide of the flat-contact housing must first be moved from the final locking position to the pre-locking position. This can be done manually (Fig. 12) or with the aid of a screwdriver (Fig. 13). Correctly coded parts are connected together by inserting the knobs of the tab housing into the corresponding grooves in the flat-contact housing (Fig. 14).

The connector is fully closed and locked by moving the slide from the pre-locking position to the final locking position. This is done by pushing on the ribbed actuating surface of the slide with one finger. The two housings are pulled together. When the slide reaches its final locking position, it latches with an audible click into the flat-contact housing (Fig. 15).

The connector is now correctly closed.

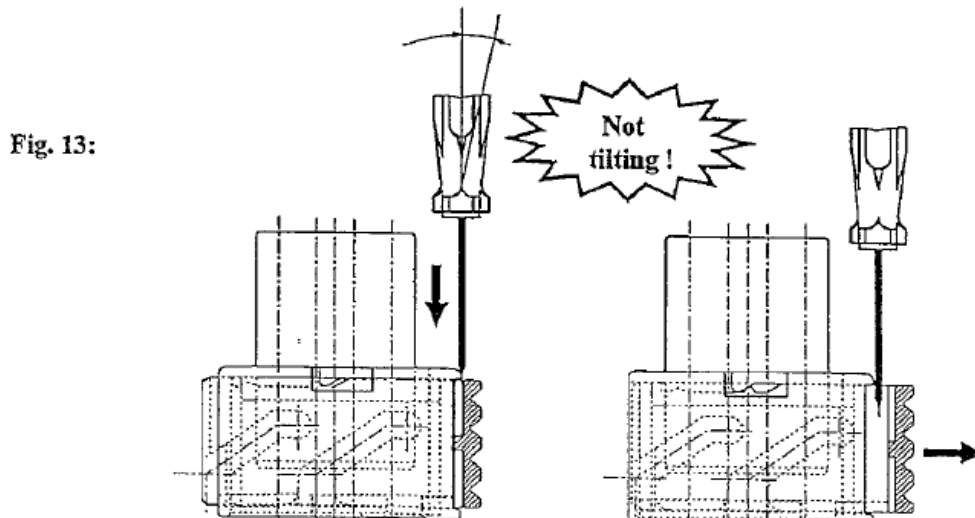
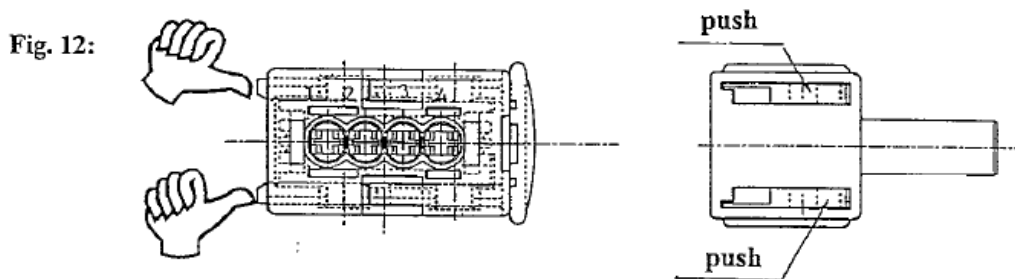

Fig. 14:

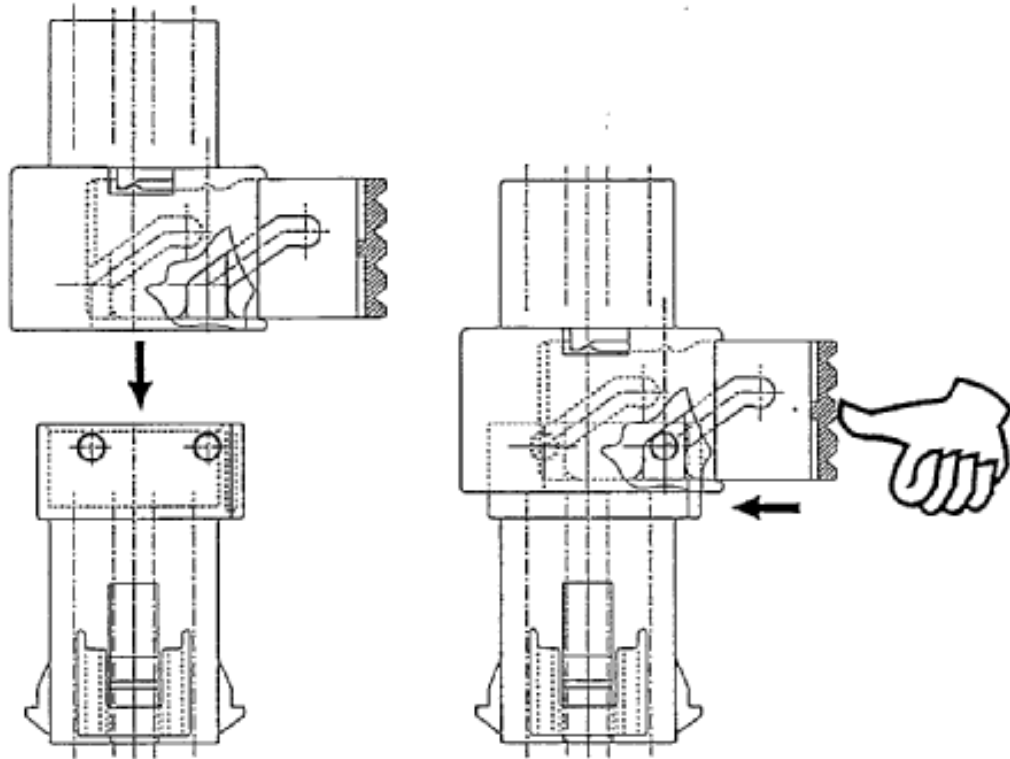
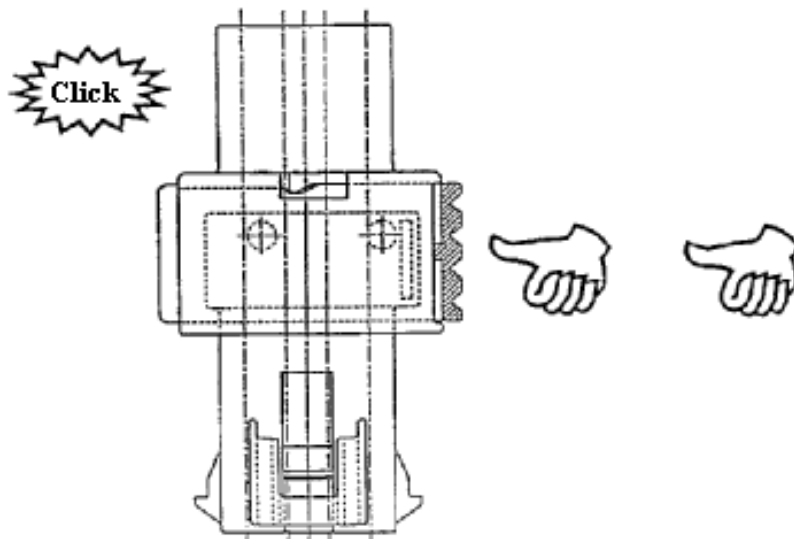

Fig. 15:



3.7.2 Closing the Flat-Contact and Tab Housings with the Slide in the Pre-Locking Position

The slide of the flat-contact housing is mounted in the pre-locking position and held there by a locking latch to prevent inadvertent actuation (Fig. 16).

Correctly coded parts are connected together by inserting the knobs of the tab housing into the corresponding grooves in the flat-contact housing.

The connector is fully closed and locked by moving the slide from the pre-locking position to the final locking position. This is done by pressing the locking latch on the side of the slide inwards with your index finger (Fig. 17) and pushing on the ribbed actuating surface of the slide with you second finger (Fig. 18). The two housings are pulled together. When the slide reaches its final locking position, it latches with an audible click into the flat-contact housing (Fig. 19). The connector is now correctly closed.

Fig. 16:

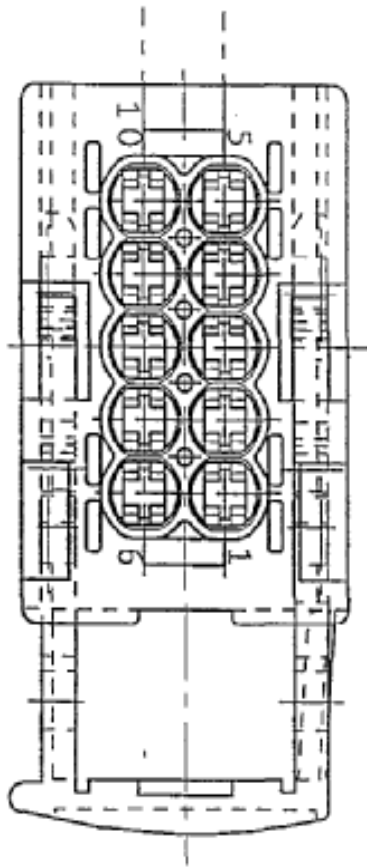

Fig. 17:

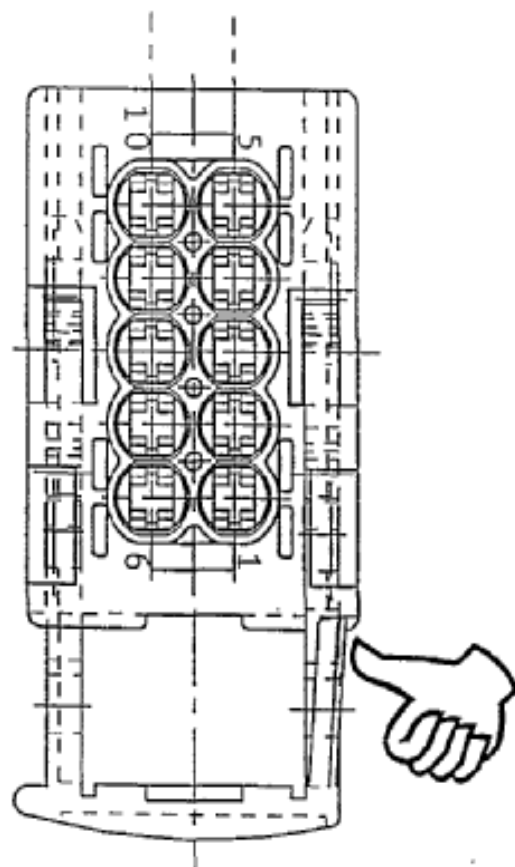

Fig. 18:

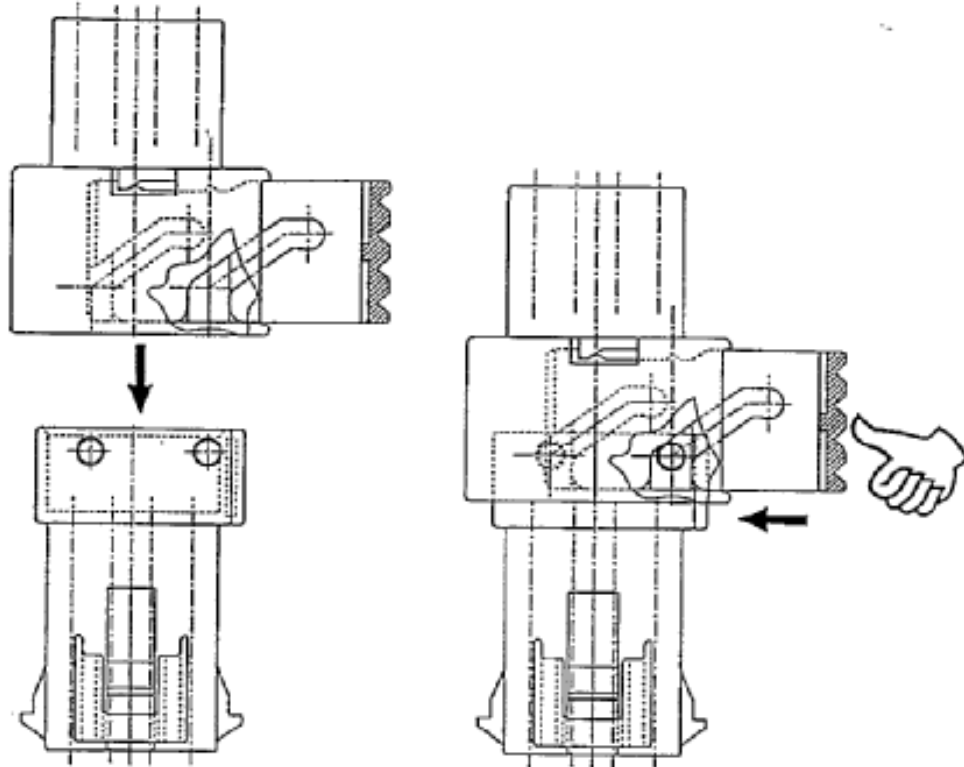
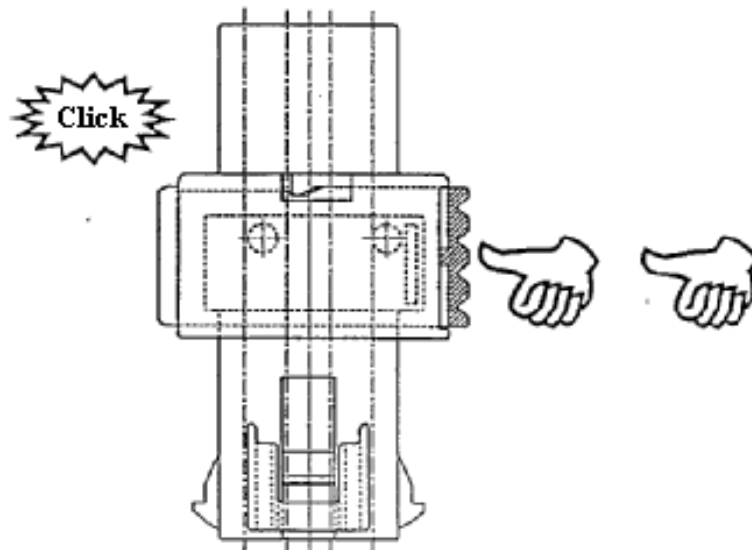

Fig. 19:



3.8 Opening the Flat-Contact and Tab Housings

The connector is opened as follows. Either press the two arms of the slide which project from the front of the slide towards the housing (Fig. 20), so that the slide moves to a position from which it can easily be pulled back, or insert a tool (such as a screwdriver) beside the slide actuation surface (Fig. 21), causing the slide to move to a position from which it can easily be moved.

In both case, the slide must be pulled fully backwards to release the connection.

Fig. 20:

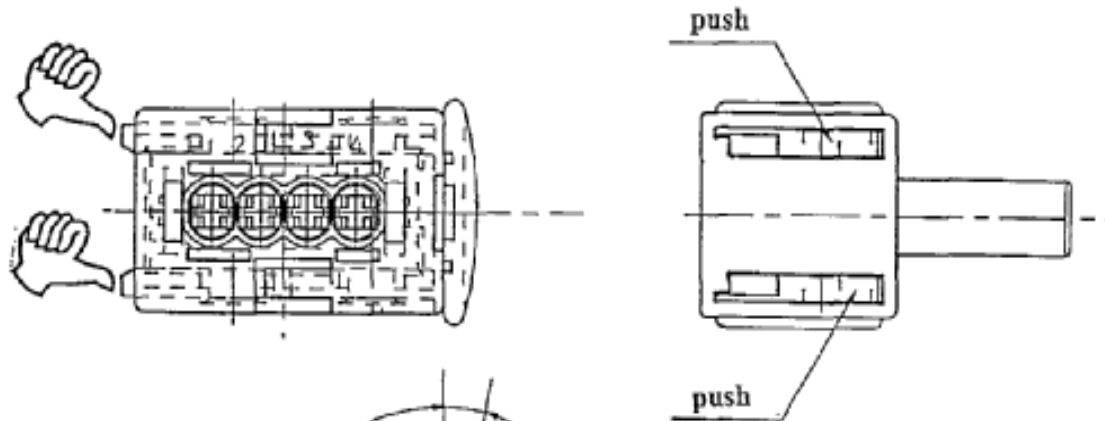
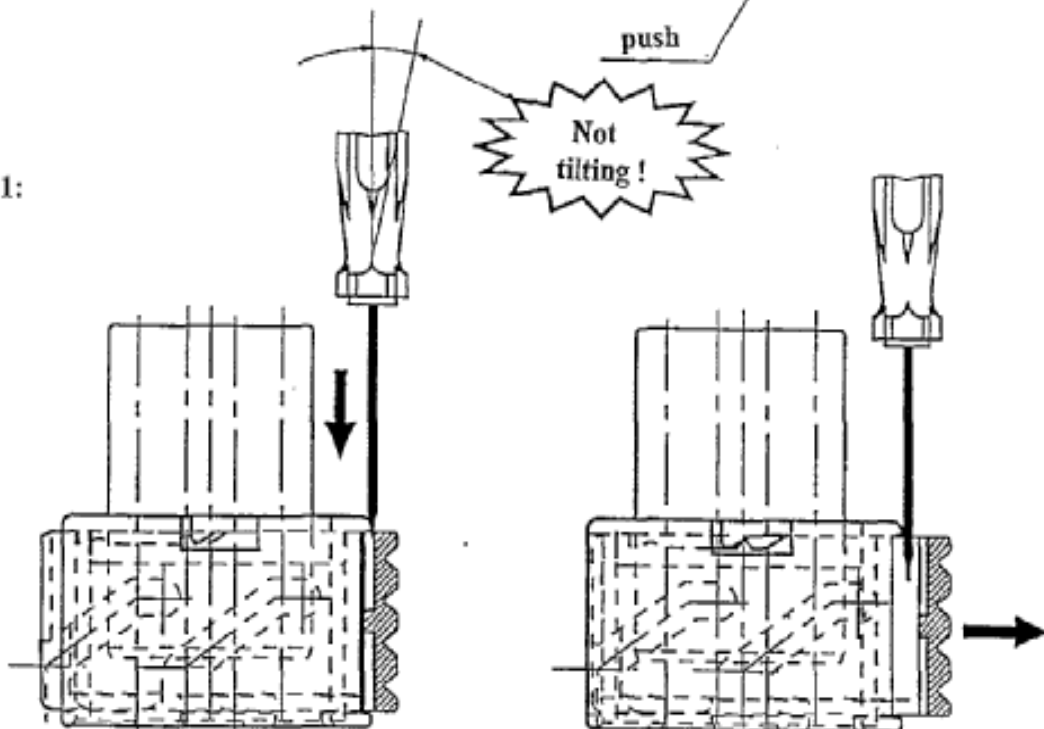
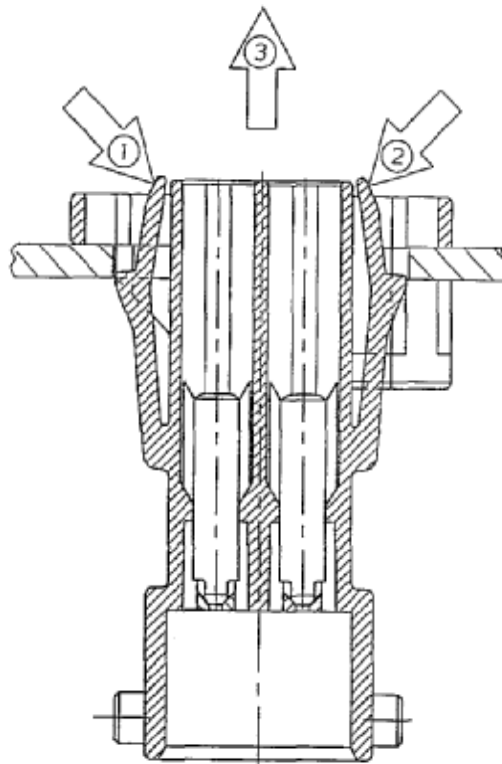

Fig. 21:



3.9 Removing the Tab Housing from the Panel Cut Out

Push the locking latch at the points marked with 1) and 2) at the figure, to the middle of the tab housing and pull simultaneously the tab housing in the direction of the arrow marked 3).



SHOWN WITHOUT CONTACTS

3.10.1 Removing the Secondary Locking Device from the Receptacle Housing

Push the locking latch from the secondary locking device at the points marked with (1) and (2) at picture 1, so as shown in picture 2 arrow (3) and so as shown in picture 3 arrow (4), to the middle of the receptacle housing and pull simultaneously the secondary locking device in the direction of the arrow marked (5). This assembly step must be done in two steps. First on point (1) as shown in picture 1 and then on point (2) as shown in picture 1 or reverse.

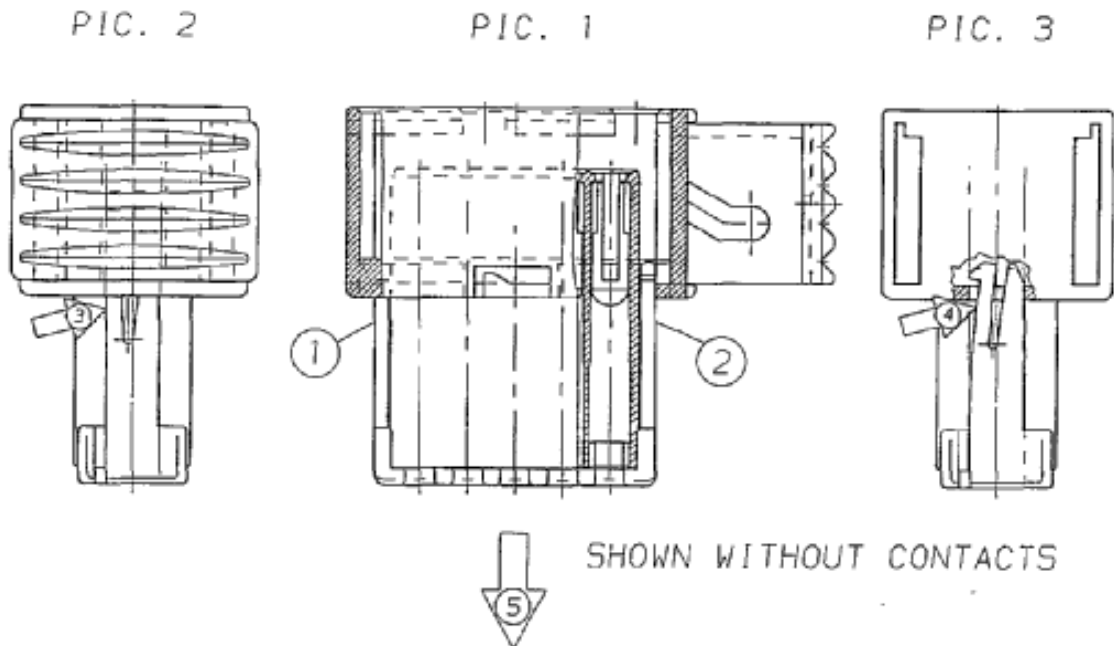

3.10.2 Removing the Secondary Locking Device from the Tab Housing

Push the secondary locking device at the point marked with arrow (1) at the picture 1 into the position as shown in picture 2. This assembly step must be repeat on the other side.

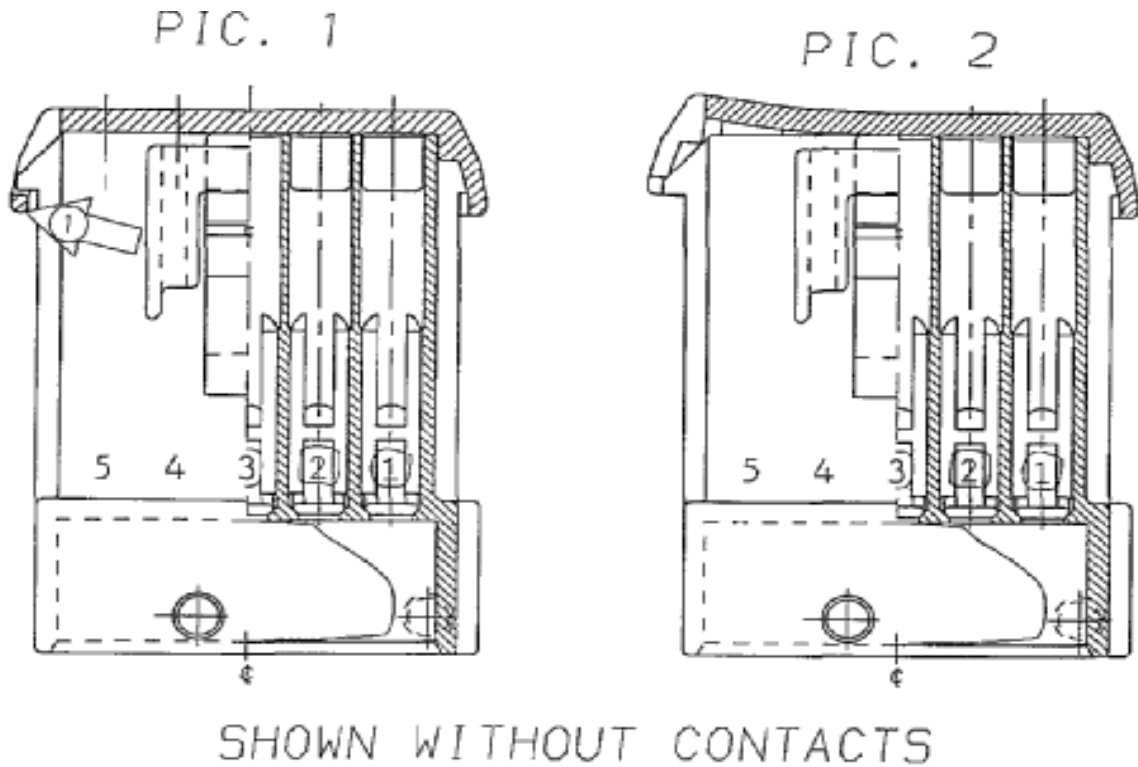

3.11 Removing the Seal from the Tab Housing

To remove the sealing from the tab housing apply a small screwdriver, or a similar tool, in one of the four corners of the housing as shown in the figure. Since the sealing could be destroyed, please scrap the sealing and take a new one to assure full functionality.

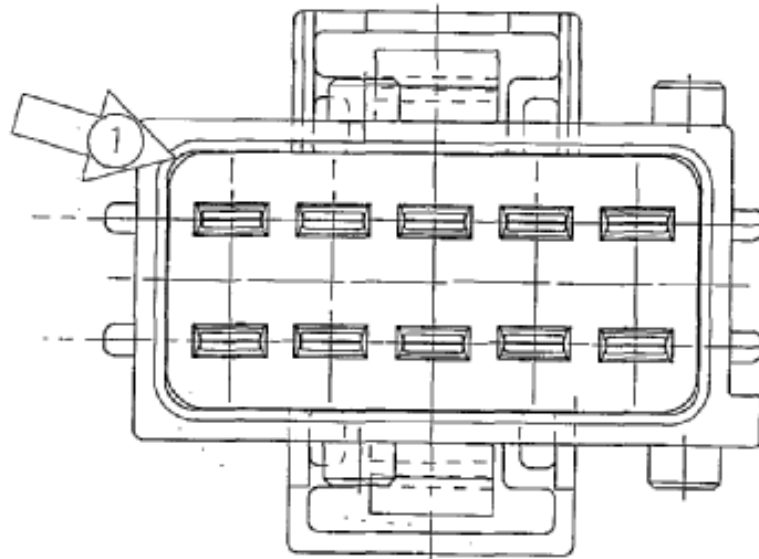

3.12 Removing Contacts from the Housing

A TE unlocking tool is required in order to remove a contact from its cavity. First remove the second contact retainer by holding it by the sides and spreading it with your fingers. It can then be pulled off.

Insert the unlocking tool from the connection side into the cavity (Fig. 22 for flat-contact housing, Fig. 23 for tab housing) as far as it will go. Then grasp the wire and pull it and the contact out of the housing.

Fig. 22:

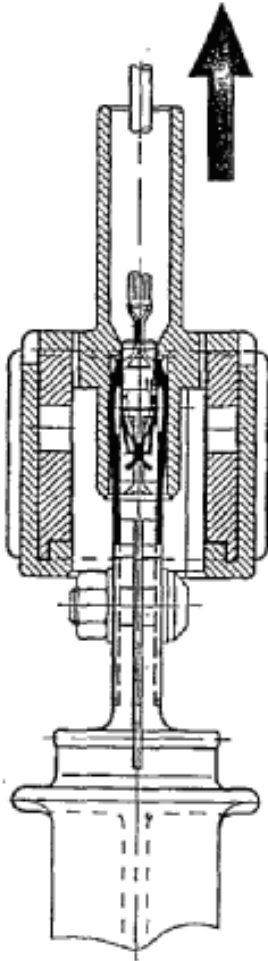
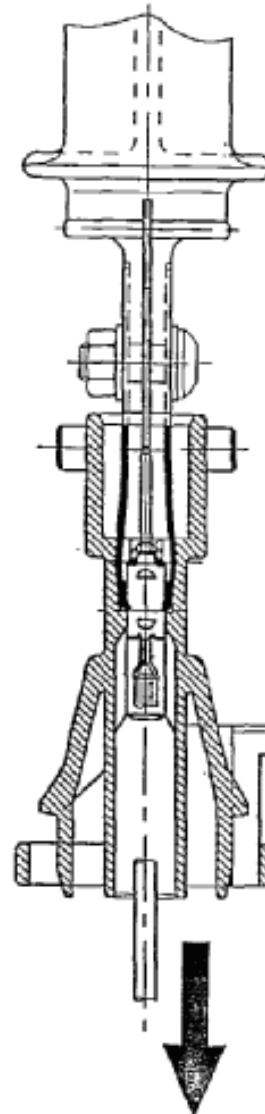

Fig. 23:



Shown with unlocking tool