



AMPMODU 2mm RECEPTACLE, Wire to Board, IDC

1 SCOPE

This application specification covers the requirements for application of the AMPMODU 2mm, Wire to Board, IDC RECEPTACLE. The system includes single row wire to board connectors with 2mm centerline. The plastic connector housings are available preloaded with insulation displacement contacts. Read these instructions before starting, to obtain a proper performance of this connector system.

2 APPLICABLE DOCUMENTS

The following documents and forms constitute a part of this specification to the extent specified herein. Unless otherwise indicated, the latest edition of the document applies.

2.1 Product specification Document

- [108-64040-2](#) AMPMODU 2mm RECEPTACLE, Wire to Board, IDC

2.2 Instruction Manual Document

- [408-6790](#) Pistol Grip Manual Hand Assembly 58074-1
- [408-6789](#) Pistol Grip Pneumatic Handle Assembly 58075-1
- [408-35127](#) Termination Head 2326300*

2.3 Application Specification

- [114-32259](#) AMPMODU 2mm, Headers and Receptacles, Board to Board

2.4 Drawings

Customer Drawings for specific products are available in te.com or via the service network. The information contained in the Customer Drawings takes priority if there is a conflict with this specification or with any other technical documentation supplied by TE Connectivity.

2.5 Supporting Documents

- [Computation of Circular Mil Area of Wire Shapes](#)
- [TE Engineering Information Management Standard](#) – IDC Termination
- [IPC-A-620](#) – Discrete Wire Termination – IDC

3 APPLICABLE PRODUCT

Connector system consists of one row housings, pre-loaded with insulation displacement contacts on 2mm centers. Assemblies are available for solid and stranded (7 strands) wires with a range of 26 through 30 AWG.

When corresponding with TE Connectivity Representatives, use the terminology provided in this specification to facilitate your inquiry for information. Basic terms and features of the connectors and contacts are provided in Figure 1.

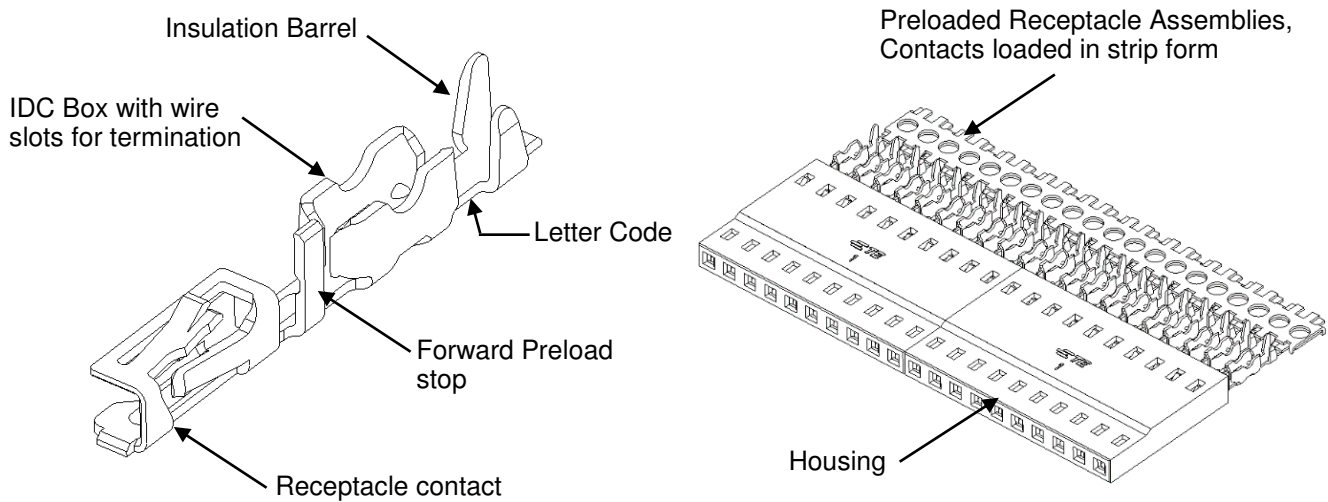

Figure 1

3.1 Product Base Numbers – Strip Form

RECEPTACLE TYPE	WIRE SIZE 26-30 AWG
Plain Housing (2 – 12 position)	2317222*
Lock Ramp or detent latch Housing (7 – 12 position)	2317223*
Center Latch Housing (3 – 12 position) **	2317224*

** Available upon request

CONTACT LETTER IDENTIFICATION

Wire Size	Letter Code
26- 30 AWG	B

3.2 Product Images

Strip Form
Plain Housing

Figure 2

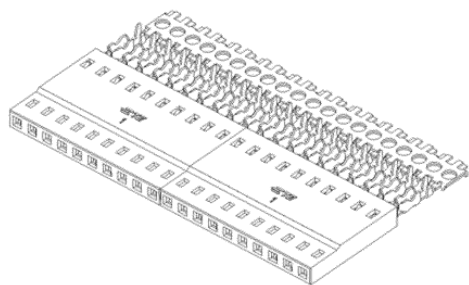

Strip Form
Lock Ramp or detent latch
Housing

Figure 3

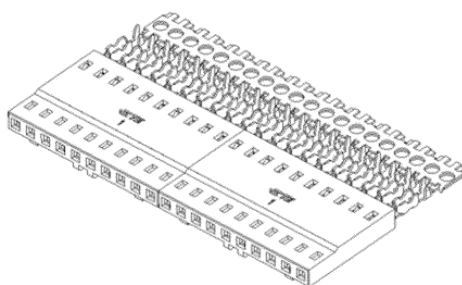

Strip Form
Center Latch Housing

Figure 4

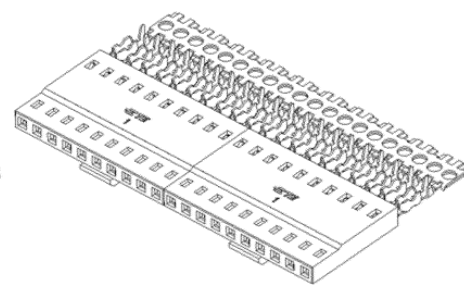
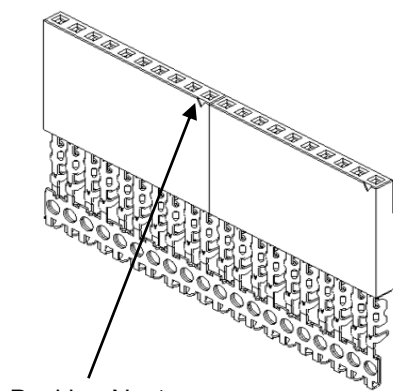

Figure 5



Position No. 1
Circuit Identifier

Figure 6

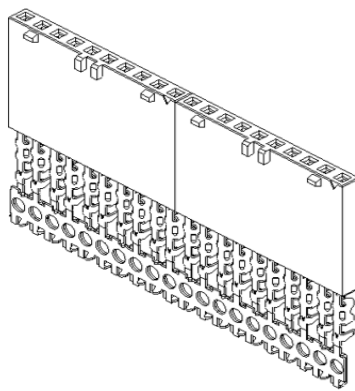

Figure 7

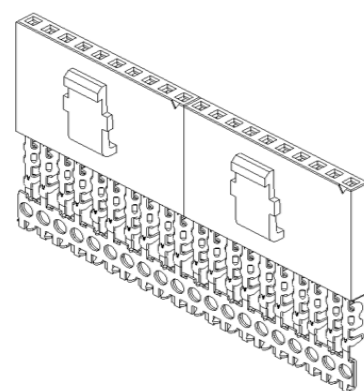

Figure 8

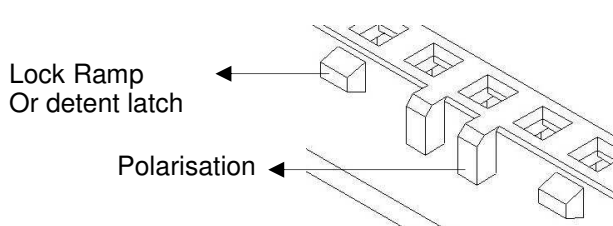
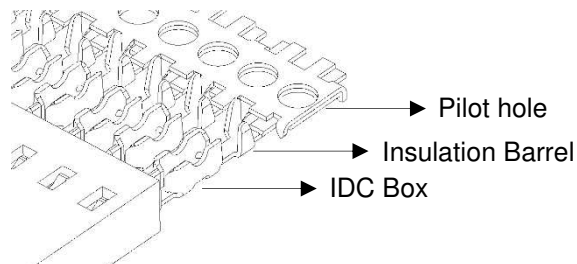

Figure 9



10 position (1 - 0) As shown

4 REQUIREMENTS

4.1 Storage:

A. Ultraviolet Light

Prolonged exposure to ultraviolet light may deteriorate the chemical composition used in the housing material.

B. Shelf Life

Each connector is packaged and shipped in an individual antistatic tube container. To prevent damage to the housings and terminals, the connectors should remain in the container until ready for installation.

C. Chemical Exposure

Do not store contacts near any of the following chemicals as they may cause stress corrosion.

Alkalis	Ammonia	Citrates	Phosphates	Citrates	Sulfur	Compounds
Amine	Carbonates	Nitrites	Sulfides	Nitrites	Tartrates	

4.2 Usage:

Only PVC / PPE insulation type wires with the following size can be used. Other wires may be suitable, however must be tested by TE Engineering before usage.

WIRE TYPE	WIRE SIZE 30-26 AWG	Termination tool	
		Cu-stranded wire 7 strands	AWG 30-26 (0.05 mm ² - 0.12 mm ²)
Cu-solid wire			
Maximum Insulation diameter	1.0mm		



Note:

*Only one wire can be used per IDC box.
Discrete wires require no preparation for termination.*

4.3. Circuit Identification

AMPMODU 2mm IDC Housings are marked with a V-shaped circuit number one identifier. See Figure 5

5 CONTACT TERMINATION

5.1 Terminating Head

Refer to the appropriate documentation for tooling operation and application procedures. The following special considerations apply to terminated contacts.

In the terminating head used for the pistol-grip hand tool, the carrier must be removed manually, and the terminals must be inserted into the housing manually as well.

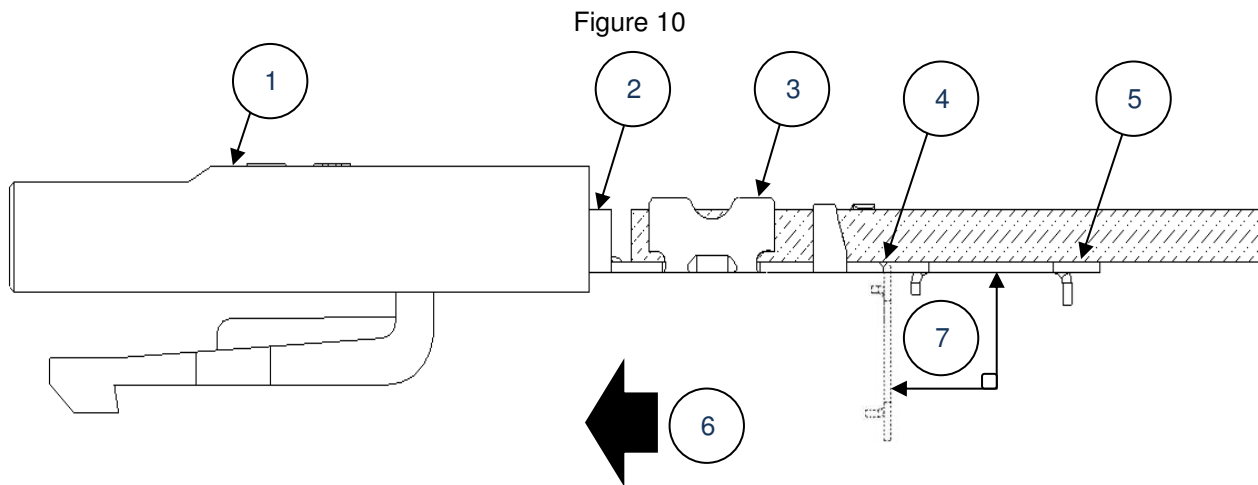

1. Typical Housing
2. Forward Preload stop bent to loading position by Applicator tooling
3. Do not Bend or otherwise damage the contact while termination or carrier strip removal
4. Cut-off Tab
5. Carrier Strip
6. Insert contacts into the housing in this direction
7. Max 90° Bend



Note:
The carrier strip edges may be sharp. Use Caution.

5.2 Forward Preload Stop

The Forward Preload stop shall be bent allowing a maximum height of 1.15mm as measured below.

Figure 11

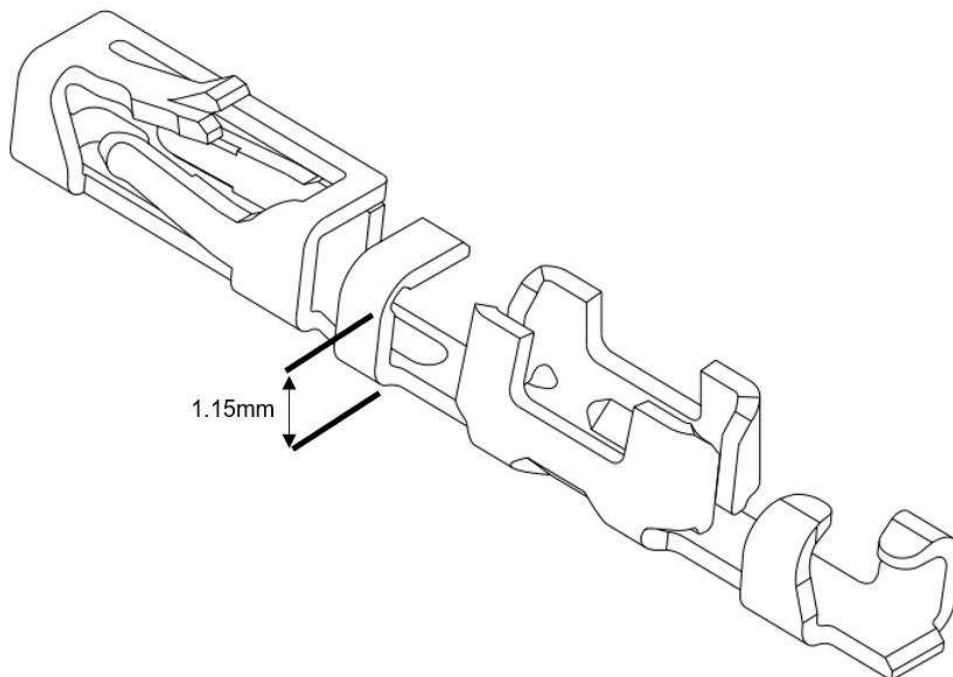

5.3 Insertion Depth

Prior to production, application tooling shall be adjusted to terminate applied wires to proper IDC slot insertion depth. Solid conductor or wire-strands shall contact the IDC within effective slot area at both slot sides. In case of stranded wire, a minimum of 3 strands total shall contact the IDC-slot. Cross sections may support judgement of proper wire insertion depth.

The top of the wire-insulation shall not extend the top of the IDC-barrel and may be a visual indication of proper insertion depth during production. Superficial damage to the wire insulation caused by the application tooling can be accepted.

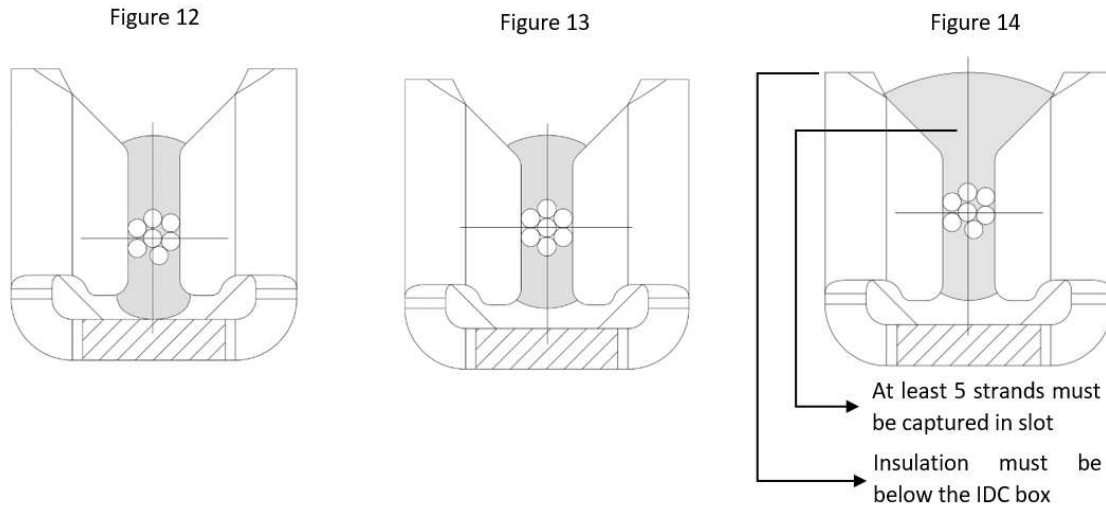

Note:

In Stranded wire 5 strands minimum must be captured in IDC slot. Remaining strands may not be above lead-in angle.



Note:

There may not be any damage to the wire slots after termination. The primary function of the insulation barrel is to prevent the conductor from lifting out of the wire slots. It must be closed adequately to confine conductor insulation.

5.4 Terminated Terminal Width

The width of the wire terminal shall not exceed 1.50 mm when terminated with the largest wire size.

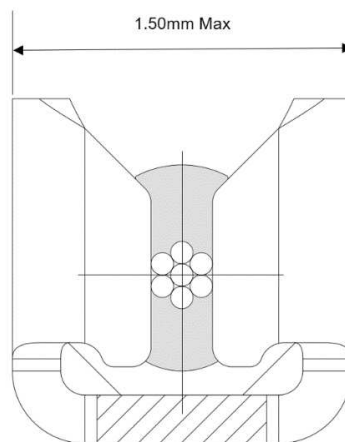
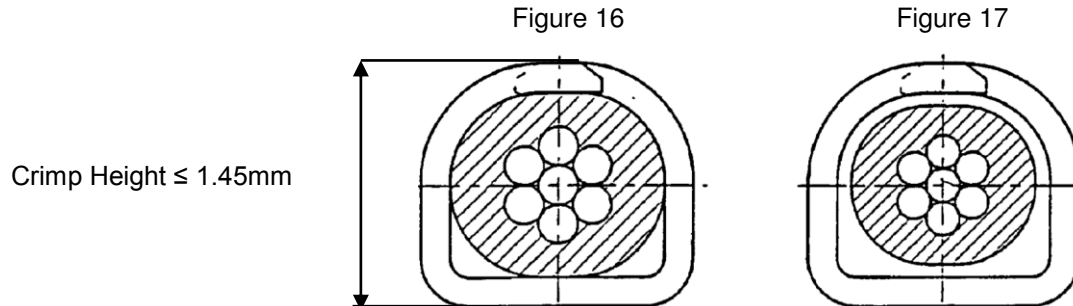

Figure 15

5.5 Insulation Support

After termination, the crimp-height of the insulation barrel shall not greater than 1.45mm for large wire size application – See Figure 16.

When the insulation diameter is too small, wire remains loose in the insulation barrel, which is acceptable – See Figure 17.



Contacts as well as housing shall show no signs of damage or deformation due to the wire termination process.



Note:

There may not be any damage to the wire slots after termination. The primary function of the insulation barrel is to prevent the conductor from lifting out of the wire slots. It must be closed adequately to confine conductor insulation.

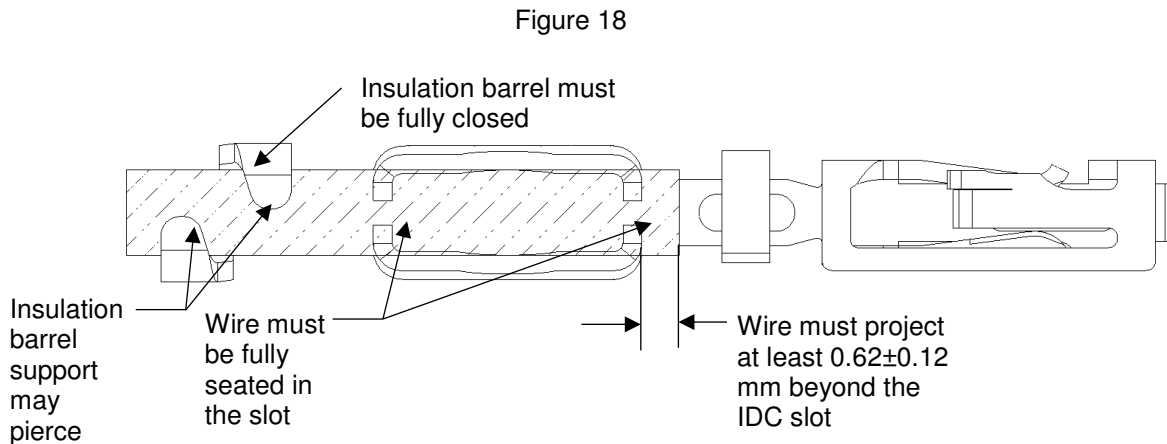

5.6 Cross section (sleeves):

- Sleeves can be used to judge the position of the conductor in the slots of the IDC barrel.
- Put the sample to be examined into a resin compound.
- The potting compound must be put in a vacuum to avoid bubbles.
- Wet-grind the section with grinding paper 60 thru 660
- The grinding direction is across the IDC BOX.
- To investigate the amount of wires which make contact, more than one sleeve is necessary.

- The section must be etched for 1 to 5 seconds, to obtain a better picture and after that must be cleaned with water and dried.
- The sleeve must be examined at the place where the strands contact the IDC slot and can be tested according the test program of DIN 41611 or IEC 60352-2.

Figure 19

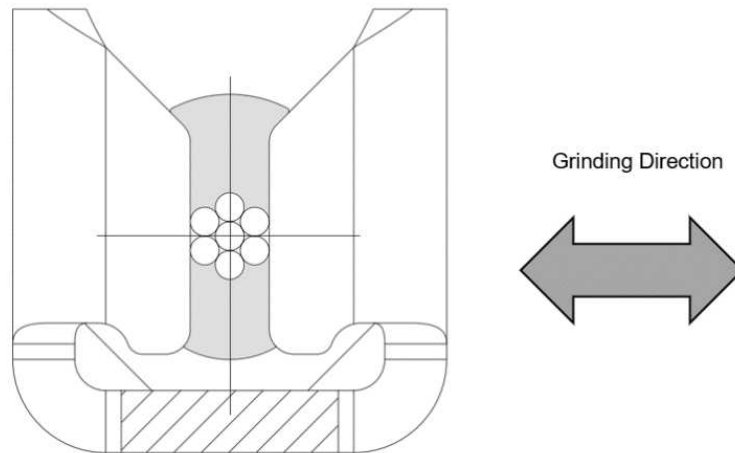

5.7 Contact Insertion

Contact shall be fully inserted into housing. Ensure locking lance is securely held in the housing window. See figure below. Pull back lightly on each wire to verify that contact is locked in place.

Figure 20

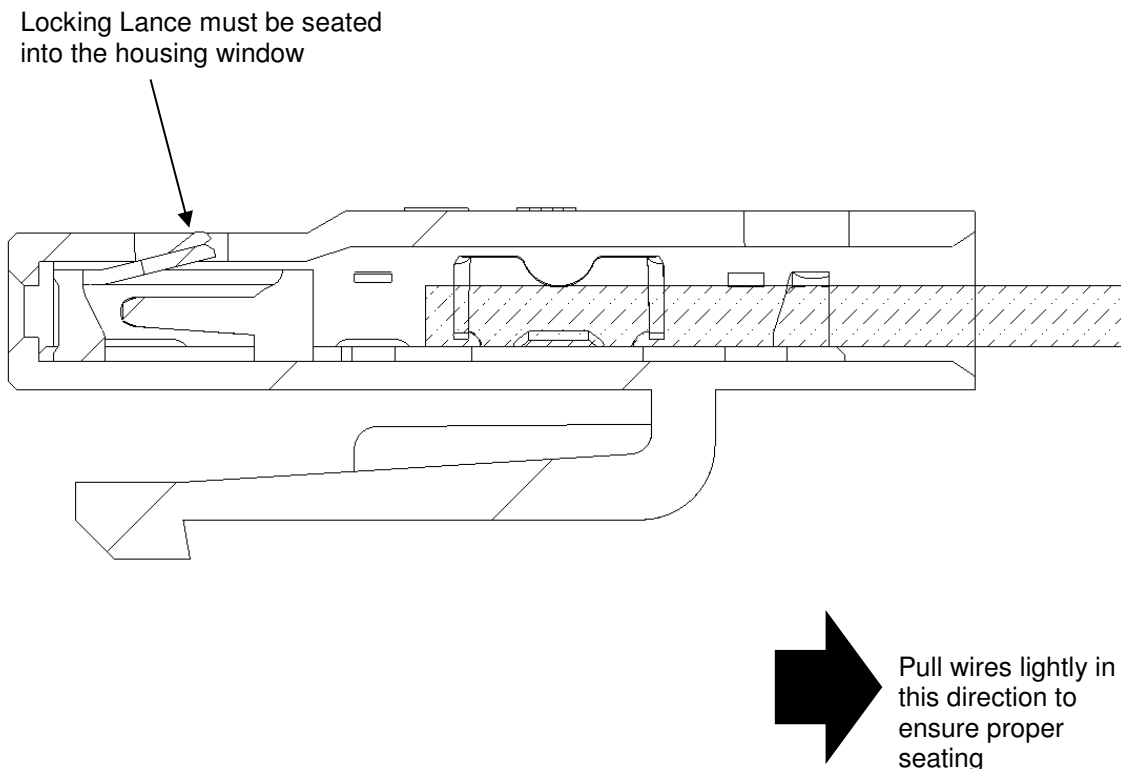

6 TOOLING

This section provides a selection of tools for various application requirements. Modified designs and additional tooling concepts may be available to meet other application requirements.

6.1 Terminating Heads

Terminating Head 2326300-1 (408-35127) terminates manually-fed wires one at a time, each time indexing to the next position. The head can be used with the Pistol-grip Manual Handle Assembly 58074-1 (408-6790) which accommodates the head for economical tooling or the Manual Pneumatic Handle 58075-1 (408-6789).

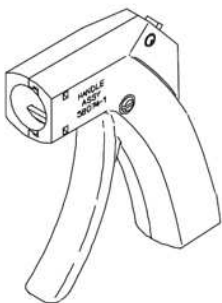

*Tool 58074-1
(408-6790)*

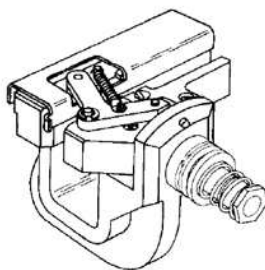

*Typical Terminating Head
2326300-1 (408-35127)*

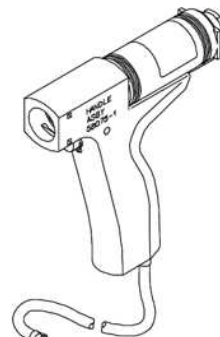

*Pneumatic Handle
Assembly 58075-1
(408-6789)*

Figure 21

6.2 Extraction Tool

The extraction tool (843477-3) can be used to disengage locking lance from the housing window. The lance release tip depresses the contact locking lance to allow extraction of the contact.

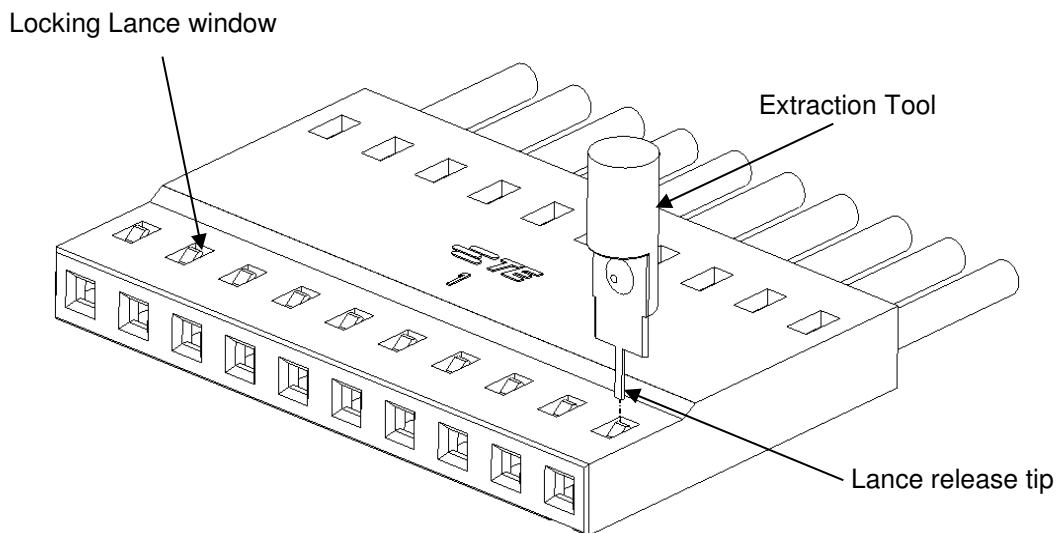

Figure 22

7 VISUAL AID

Figure 23 shows a typical application of an AMPMODU IDC Interconnection System. This illustration should be used by production personnel to ensure a correctly applied product. Applications which DO NOT appear correct should be inspected using the information in the preceding pages of this specification.

Figure 23

