

1. SCOPE

This specification is to provide the requirements for i) crimping of contacts and ii) panel mounting for High Current Hybrid Drawer connector.

2. APPLICABLE CONTACTS:

All applicable contact Part Numbers in the High Current Hybrid Drawer Connector series are as listed in Table 1. Some contacts may have the crimping requirements referenced to other Application Specifications. Please refer to those specifications as necessary.

Contact P/N	Description	Refer to Application Spec. No.
84696-1	"S" Size Power Tab Dynamic Contact	114-51009
84695-1	"M" Size Power Tab Dynamic Contact	114-51009
179955-2	"S" Size Power Receptacle Dynamic Contact (Strip)	114-5206
179956-2	"M" Size Power Receptacle Dynamic Contact (Strip)	114-5206
316040-2	"S" Size Power Receptacle Dynamic Contact (L/P)	114-5206
316041-2	"M" Size Power Receptacle Dynamic Contact (L/P)	114-5206
x-179316-x x-179333-x	Power Receptacle Contact, MIC Contact (#20 - #16 AWG)	114-5182
x-179317-x x-179334-x	MIC Receptacle Contact, MIC Contact (#24 - #20 AWG)	114-5182
x-316458-x x-1123943-x	Ground Receptacle Contact, MIC Contact (#20 - #16 AWG)	114-5182
x-179321-x x-179335-x	Power Tab Contact, MIC Contact (#20 - #16 AWG)	114-5182
x-179322-x x-179336-x	Power Tab Contact, MIC Contact (#24 - #20 AWG)	114-5182

Table 1

THIS INFORMATION IS CONFIDENTIAL AND IS DISCLOSED TO YOU ON CONDITION THAT NO FURTHER DISCLOSURE IS MADE BY YOU TO OTHER THAN AMP PERSONNEL WITHOUT WRITTEN AUTHORIZATION FROM AMP MANUFACTURING SINGAPORE PTE LTD

		DR L. P. TAN 15/2/01		AMP LTD AMP MANUFACTURING (SINGAPORE) PTE 26 ANG MO KIO INDUSTRIAL PARK 2 SINGAPORE 569507 TEL : 4820311 (20 LINES)	
		CHK W. L. CHOO 20/6/01		NO 114-51009	
		APP SEE LAST PAGE		REV A	LOC DY
A	Released FP00-0254-01	TLP	13/09/01	PAGE 1 OF 5	TITLE Crimping of D-5000 Contacts For High Current Hybrid Drawer Connector
O	Released FP00-0087-01	TLP	15/2/01		
LTR	REVISION RECORD	DR	DATE		

3. NOMENCLATURE OF CONTACT:

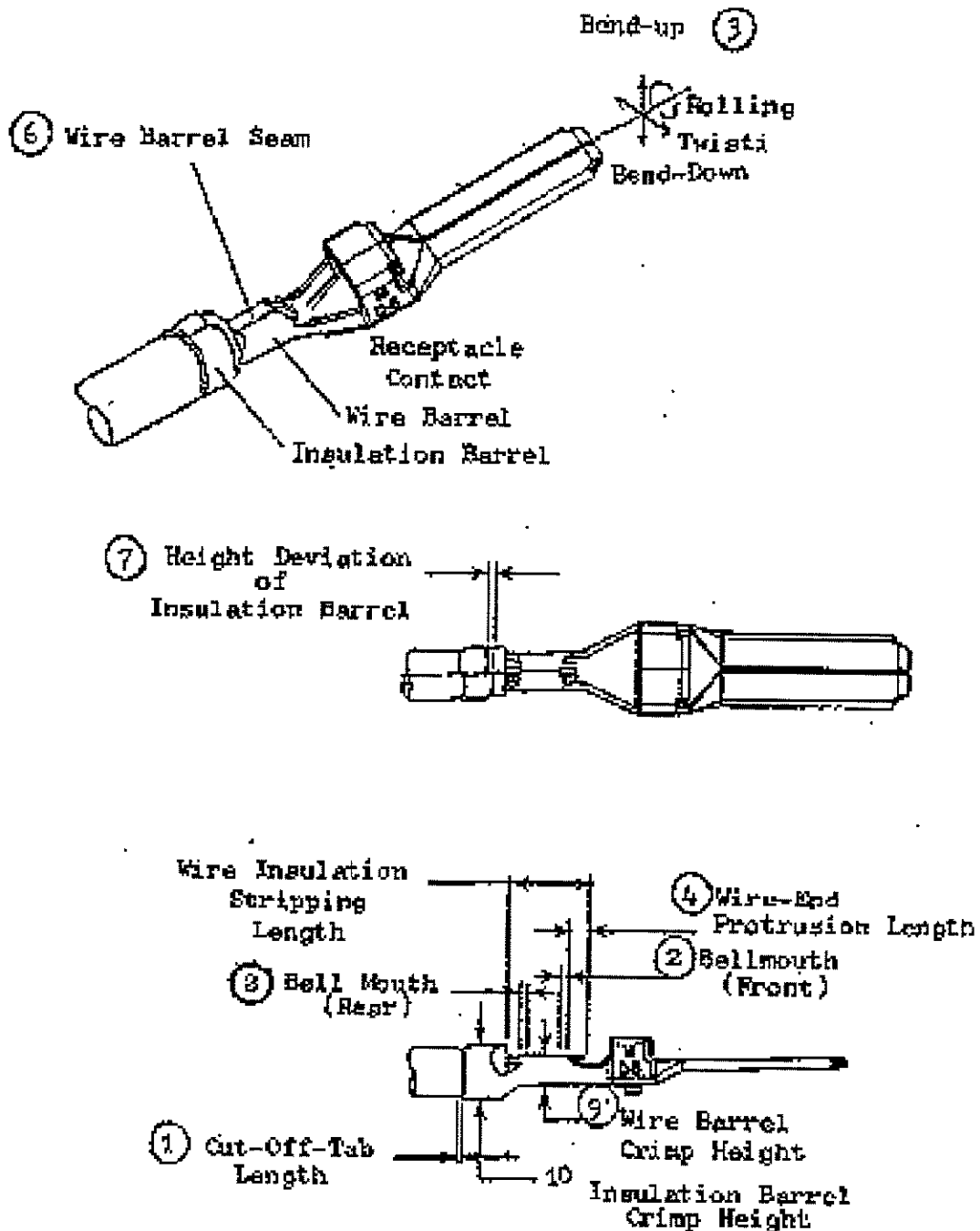

Fig. 1

4. CRIMPING CONDITIONS AND CRIMP DATA:

4.1 Crimping conditions:

Check Items		Crimping Conditions		Remarks
		P/Ns per para. 2 (page 1)		
Cut-off-tab length		0.5mm Max.		Fig. 1 (1)
Bellmouth	Front	Must be visibly confirmed		Fig. 1 (2)
	Rear	0.2~ 0.9mm (visibly confirmable)		
Deformation after Crimping	Bend	Up: 2° Max.	Down: 5° Max.	Fig. 1 (3)
	Twist	2° Max.		
	Rolling	3° Max.		
Wire End Protrusion Length		0.5 ~ 2.0mm		Fig. 1 (4)
Insulation Stripping Length		S size: 4.8 ± 0.5mm, M size: 6.3 ± 0.5mm		Fig. 1 (5)
Wire Barrel Seam		Seam must be neatly closed		Fig. 1 (6)
Height Deviation of Insulation Barrel		0.5mm Max.		Fig. 1 (7)

4.2 Crimp Data (Applicator Crimp):

Contact P/N	Wire Size (mm ²)	AWG	Applicator Assy P/N	Wire Barrel Crimp			Insulation Barrel Crimp			Crimp Tensile Strength N (kgf) Min.
				Width (mm)	Height (see note 1)	Disc Ltr.	Width (mm)	Wire Insulation Dia.	Crimp Height (mm)	
84696-1	1.23 ~ 1.42	16	1366659-2	2.79 "F"	1.90	B	4.83 "F"	3.00	3.91	186.2 (19)
								3.60	4.14	
	2.00 ~ 2.27	14			2.11	A		3.00	3.91	245.0 (25)
								3.80	4.22	
84695-1	3.08 ~ 3.62	12	1366660-2	4.06 "F"	2.32	B	6.10 "F"	4.00	4.85	313.6 (32)
								5.00	5.27	
	4.6 ~ 5.5	10			2.63	A		4.00	4.85	401.8 (41)
								5.20	5.27	

Notes:

1. Tolerance of wire barrel crimp height to be within ± 0.05 mm. Fig 1 (9).
2. Unless otherwise noted, all the dimensions to be in millimeter.
3. The wire insulation diameter shown above is of finished, crimped wire insulation diameter. (See Para. 5)

5. APPLICABLE WIRES:

Wire Sizes	No. of Conductors / Diameter of a Conductor			Calculated Cross-sectional Area (mm ²)			Insulation Diameter		Wire Specification
1.309mm ² (AWG #16)	26/0.254	54/0.18	26/0.26	1.317	1.373	1.380	3.15 STD	UL1015	
							3.23		
2.081mm ² (AWG #14)	41/0.254	41/0.26	2.076	2.176			3.54		
							3.77		
3.309mm ² (AWG #12)	65/0.254	65/0.26	43/0.32	3.292	3.449	3.457	4.04		
							4.12		
5.262mm ² (AWG #10)	104/0.254	66/0.32	43/0.40	5.267	5.305	5.401	4.64		
							4.89		▼

6. PANEL MOUNTING OF HIGH CURRENT HYBRID CONNECTOR

Recommended locking torque to mount the connector is 98~ 147N (10~ 15 kgf).

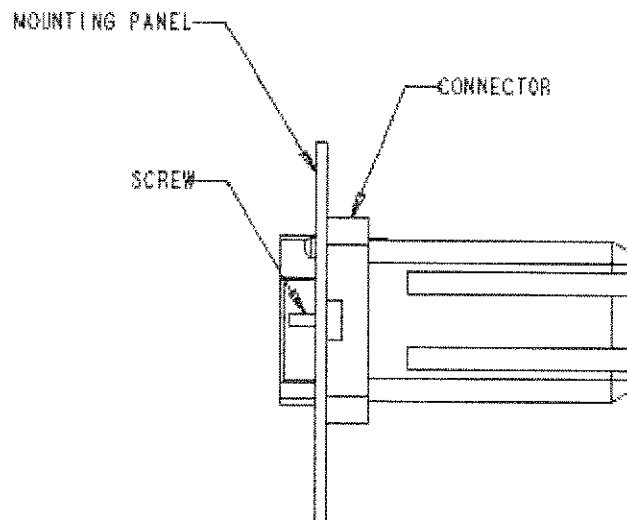



Fig. 2

AMP	AMP MANUFACTURING SINGAPORE PTE LTD No. 26, Ang Mo Kio Industrial Park 2, Singapore 569507	PAGE	NO	REV	LOC
		4	114-51009	A	DY

7. VALIDATIONS

Prepared by:

 20 SEP '01

Tan Lay Peng
Product Engineer
Product Engineering
Tyco Electronics Singapore Pte. Ltd.

Reviwed by:

 20 SEP '01

Choo Wing Lian
Product Engineering Manager
Product Engineering
Tyco Electronics Singapore Pte. Ltd.

Approved by:

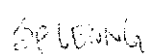
 20 SEP '01

Leong See Fan
Product Engineering Division Manager
Product Engineering
Tyco Electronics Singapore Pte. Ltd

AMP

AMP MANUFACTURING SINGAPORE PTE LTD
No. 26, Ang Mo Kio Industrial Park 2,
Singapore 569507

PAGE

NO

114-51009

REV

A

LOC

DY

5