

4

3

2

1

THIS DRAWING IS UNPUBLISHED. RELEASED FOR PUBLICATION
 © COPYRIGHT BY TYCO ELECTRONICS CORPORATION. ALL RIGHTS RESERVED.

LOC	DIST	REVISIONS			
P	LTR	DESCRIPTION	DATE	DWN	APVD
DS		RELEASED	13.OCT.'08	JY	HG

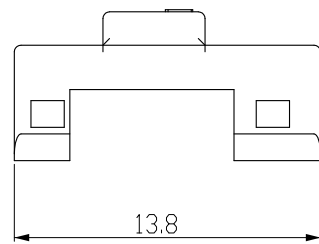
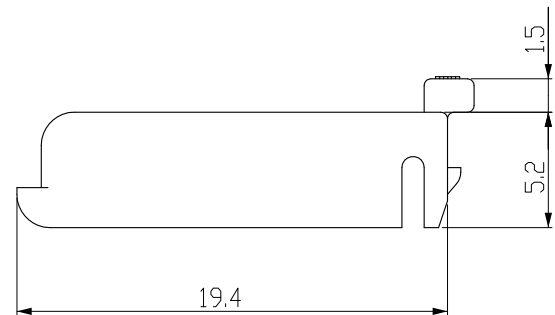
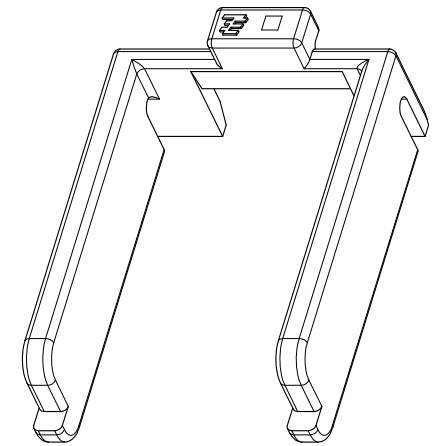
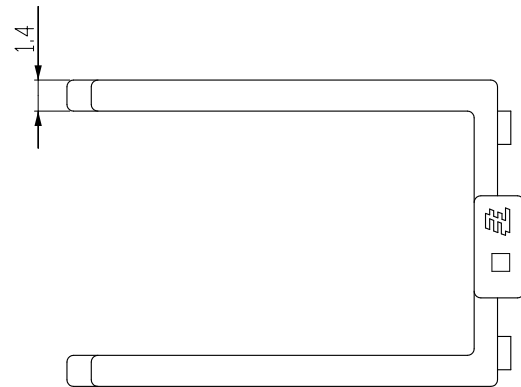

NOTE

- 1. GENERAL TOLERANCE: ±0.3
- 2. APPLICABLE HSG P/NO : 1897699
- 3. APPLICATION TEST SPEC : GMW-3191

BLACK	PBT	0-1897700-2
COLOR	MATERIAL	P/N

<small>THIS DRAWING IS A CONTROLLED DOCUMENT FOR TYCO ELECTRONICS CORPORATION IT IS SUBJECT TO CHANGE AND THE CONTROLLING ENGINEERING ORGANIZATION SHOULD BE CONTACTED FOR THE LATEST REVISION.</small>		D/WN JY BAE CHK YM CHOI APVD HG CHOI PRODUCT SPEC APPLICATION SPEC WEIGHT CUSTOMER DRAWING		Tyco Electronics AMP KOREA kyungsan, korea	
DIMENSIONS: MM	TOLERANCES UNLESS OTHERWISE SPECIFIED:	NAME REAR HOLDER FOR DOOR TO BODY 11P PLUG HSG			
 3rd ANGLE PROJECTION	0 PLC ± 1 PLC ± 2 PLC ± 3 PLC ± 4 PLC ± ANGLES ±	SIZE A3	CAGE CODE 00079	DRAWING NO 1897700	RESTRICTED TO —
MATERIAL SEE TABLE	FINISH	SCALE 2:1		SHEET 1 OF 1	REV A