

THIS DRAWING IS UNPUBLISHED. RELEASED FOR PUBLICATION 20  
 © COPYRIGHT 20 BY - ALL RIGHTS RESERVED.

LOC	DIST	REVISIONS			
P	LTR	DESCRIPTION	DATE	DWN	APVD
ES	-	A	NEW REREASE	22AUG12	T.Z S.Y
		B	REVISED ECO-19-014817	26SEP19	K.G W.H

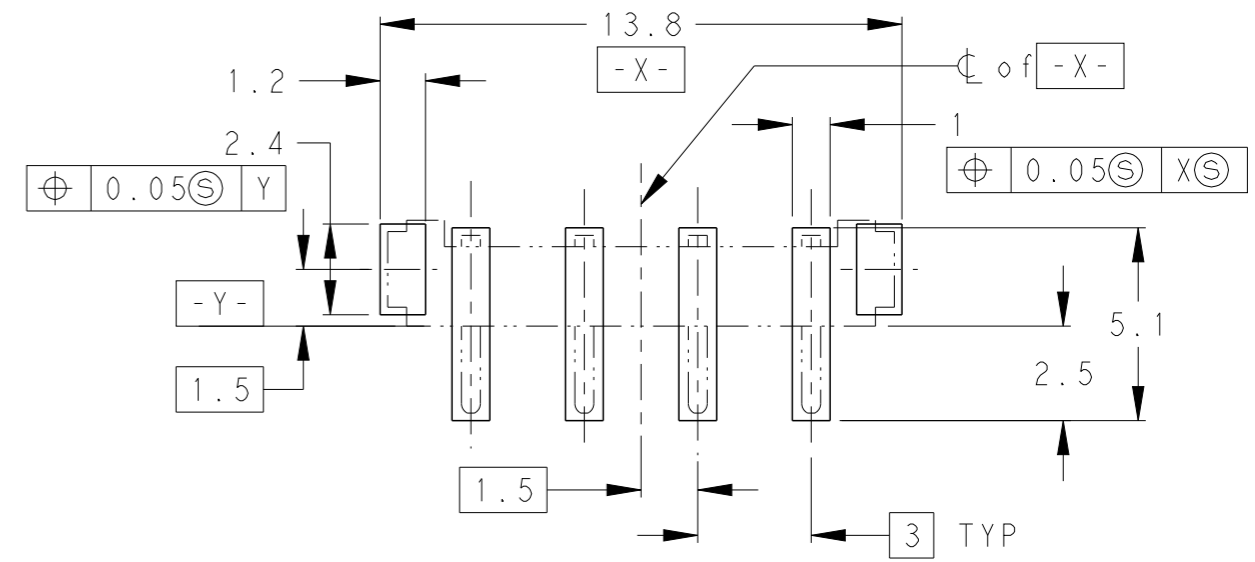

REFERENCE P.C BOARD LAYOUT  
 (GENERAL TOLERANCE: ±0.05, SCALE 5:1)

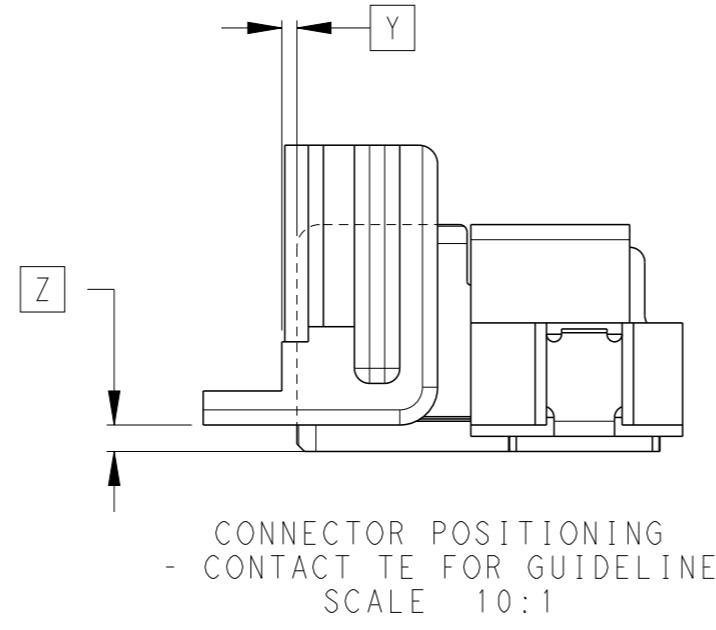
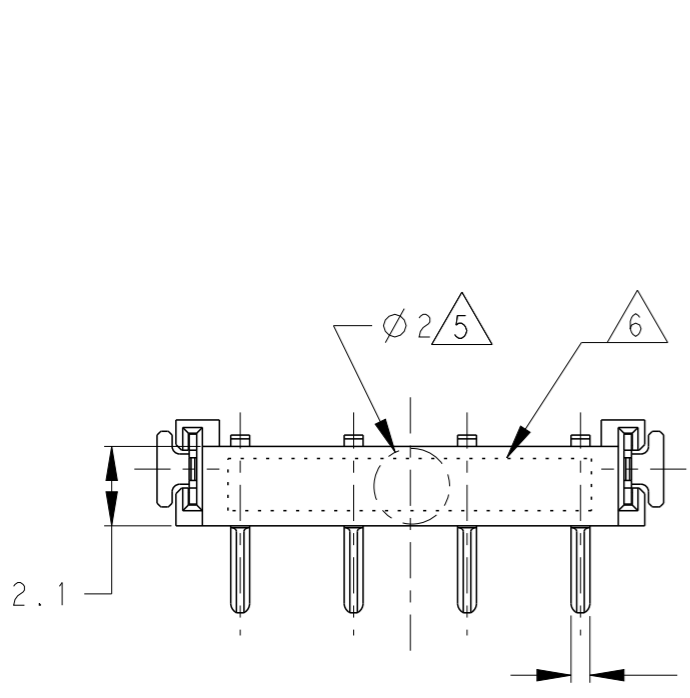
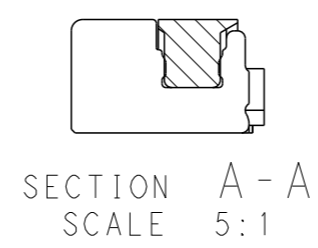
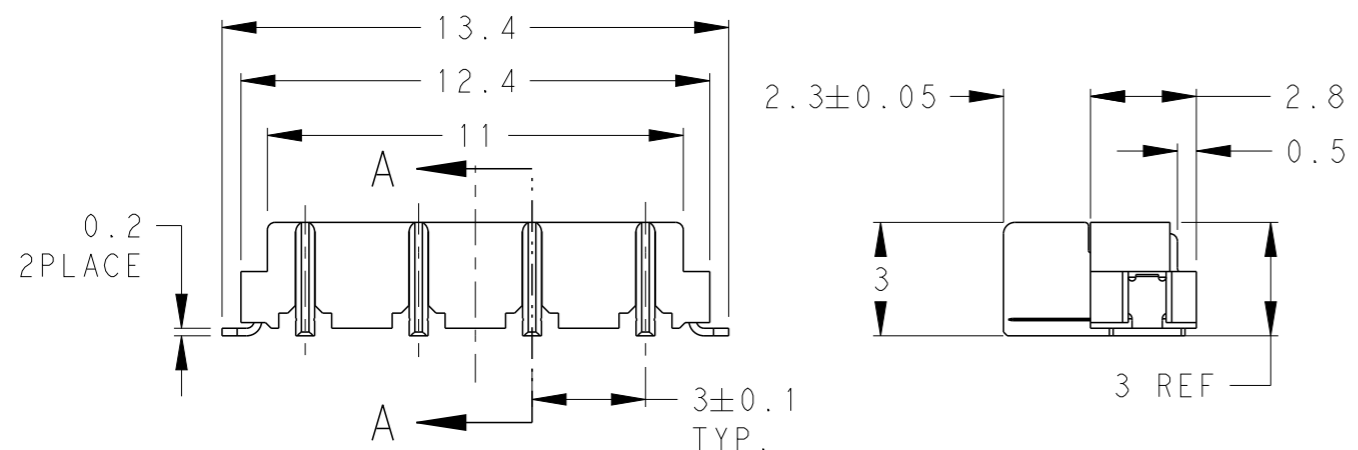

- 1. MATERIAL  
 CONTACT: BRASS  
 HOUSING: LCP, UL94V-0, BLACK  
 SOLDER PEG: BRASS
- 2. FINISH  
 CONTACT: NICKEL ALL OVER UNDER PLATING, 3.0um MIN.  
 GOLD PLATING AT CONTACT AREA, 0.76um MIN.  
 GOLD FLASH PLATING AT LEAD AREA, 0.05-0.2um
- 3. FINISH  
 SOLDER PEG: NICKEL ALL OVER UNDER PLATING, 1.27um MIN.  
 TIN PLATING ALL OVER, 2-5um
- 4. COPLANARITY 0.08MAX.
- 5. PICKING AREA
- 6. DATE CODE

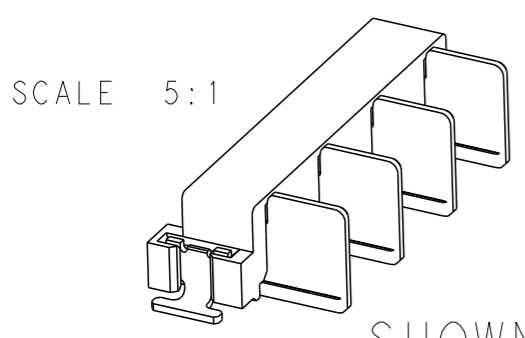
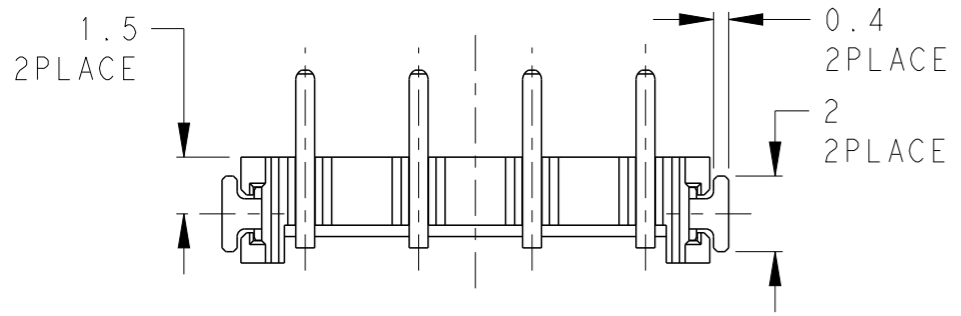

SHOWN AS : 2134167-1

THIS DRAWING IS A CONTROLLED DOCUMENT.		DWN Tony Zhang 22AUG12	TE Connectivity		
DIMENSIONS: mm		CHK Xu Xiang 22AUG12			
TOLERANCES UNLESS OTHERWISE SPECIFIED: ±0.15		APVD Steven Yao 22AUG12			
0 PLC ± 1 PLC ±0.5 2 PLC ±0.13 3 PLC ±0.013 4 PLC ±0.0001 ANGLES ±		NAME			
MATERIAL 1		FINISH 2	PRODUCT SPEC 108-61125 APPLICATION SPEC WEIGHT - CUSTOMER DRAWING		
		SIZE A3	CAGE CODE 00779	DRAWING NO. 2134167	RESTRICTED TO -
		SCALE 5:1		SHEET 1 OF 2	REV B

THIS DRAWING IS UNPUBLISHED. RELEASED FOR PUBLICATION 20  
 © COPYRIGHT 20 BY - ALL RIGHTS RESERVED.

LOC	DIST	REVISIONS			
P	LTR	DESCRIPTION	DATE	DWN	APVD
ES	-	SEE SHEET 1	-	-	-

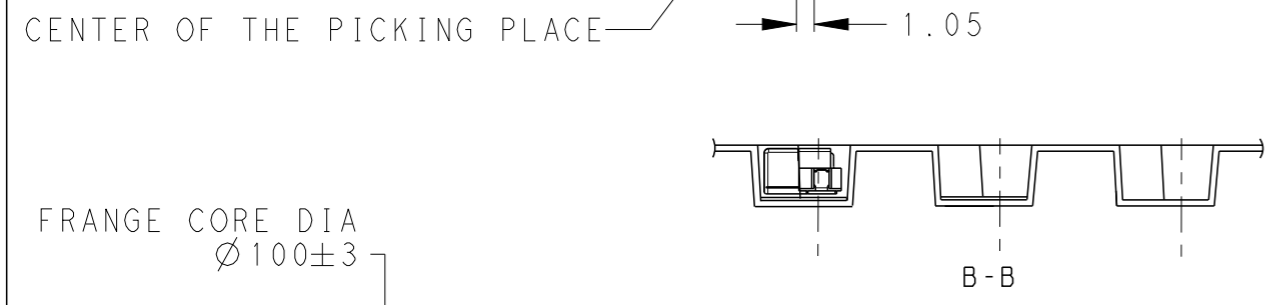
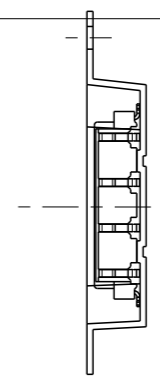
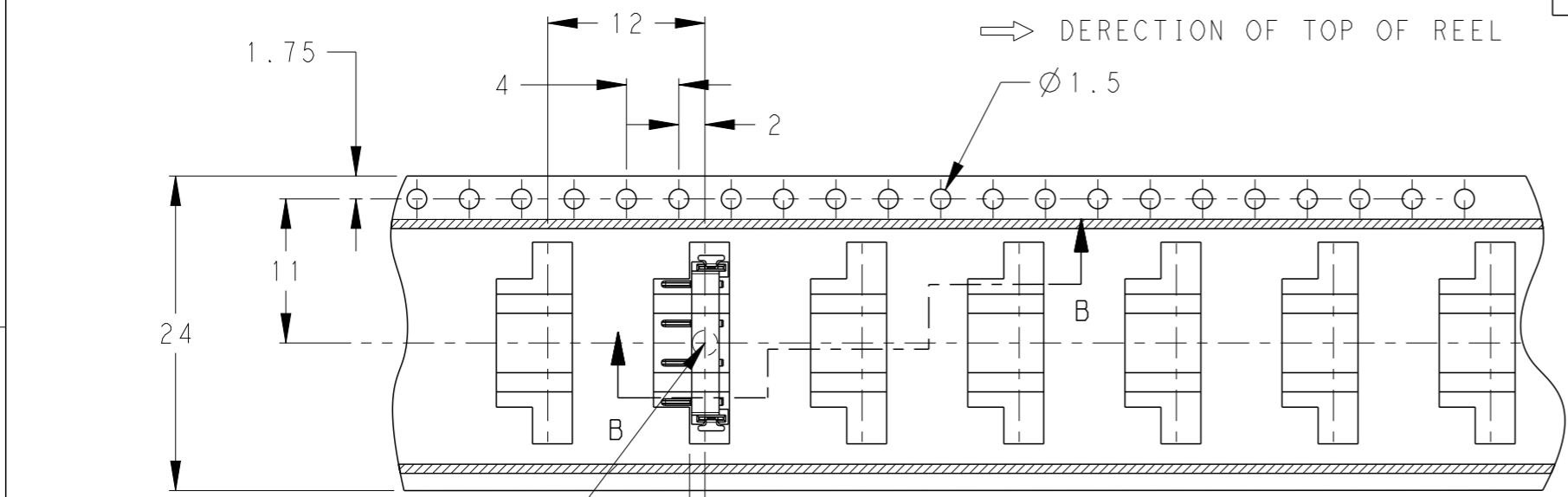

FRANGE CORE DIA  
 $\varnothing 100 \pm 3$

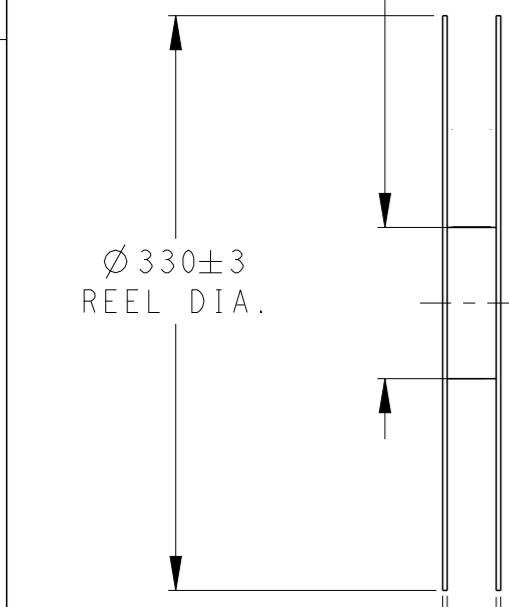

$\varnothing 330 \pm 3$   
 REEL DIA.

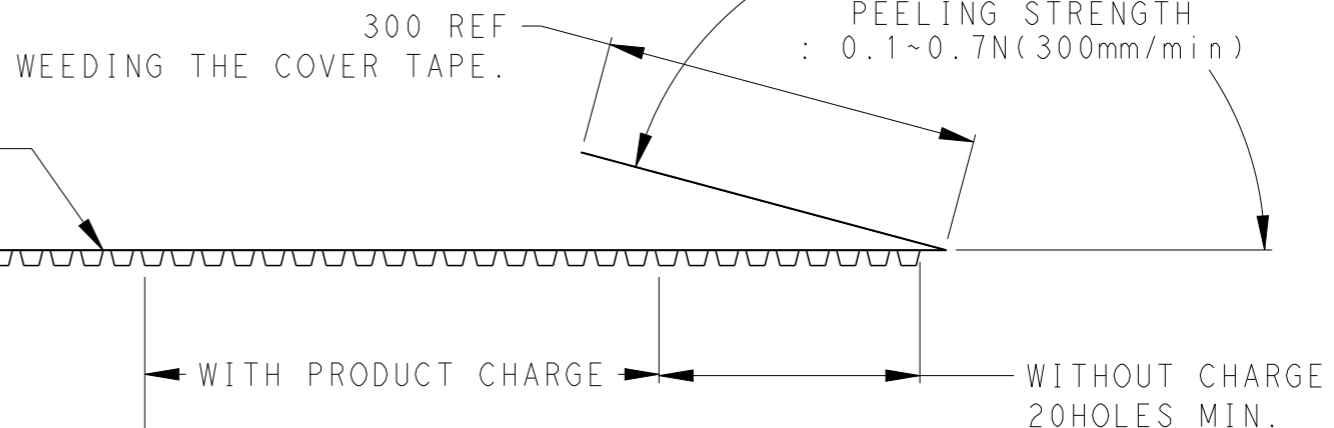
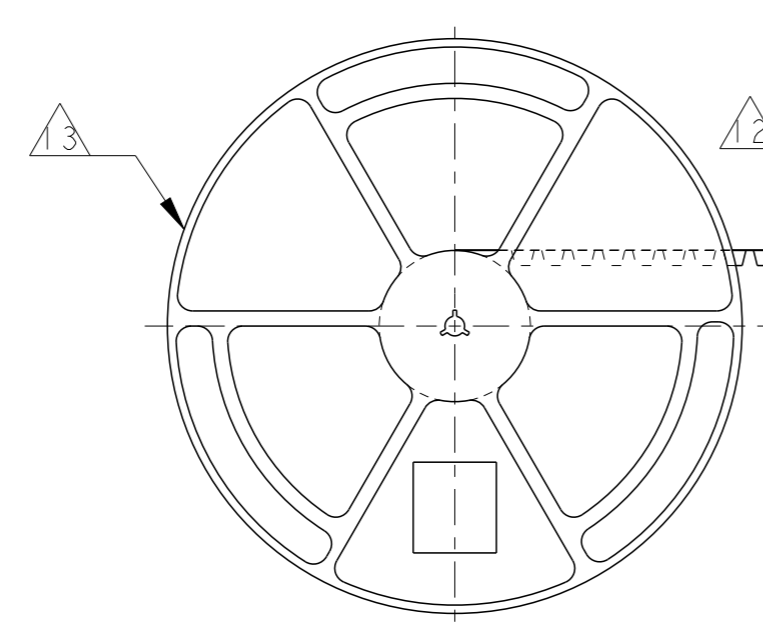

300 REF  
 WITHOUT CHARGE

1-2134167-1: AS SHOWN

THIS DRAWING IS A CONTROLLED DOCUMENT.		DWN Tony Zhang 22AUG12	 TE Connectivity
DIMENSIONS: mm		CHK Xu Xiang 22AUG12	
TOLERANCES UNLESS OTHERWISE SPECIFIED: $\pm 0.3$		APVD Steven Yao 22AUG12	
0 PLC $\pm$ 1 PLC $\pm 0.5$ 2 PLC $\pm 0.13$ 3 PLC $\pm 0.013$ 4 PLC $\pm 0.0001$ ANGLES $\pm$		NAME 108-61125	
MATERIAL -		PRODUCT SPEC 108-61125	APPLICATION SPEC
FINISH SEE TABLE		WEIGHT -	RESTRICTED TO -
CUSTOMER DRAWING		SCALE 2:1	SIZE A3 CAGE CODE 00779 DRAWING NO. C-2134167 SHEET 2 OF 2 REV B