

THIS DRAWING IS UNPUBLISHED.

RELEASED FOR PUBLICATION

-. - .

© COPYRIGHT - By -

ALL RIGHTS RESERVED.

REVISIONS

P	LTR	DESCRIPTION	DATE	DWN	APVD
	B	UPDATED DRAWING	04-Oct-16	GL	-

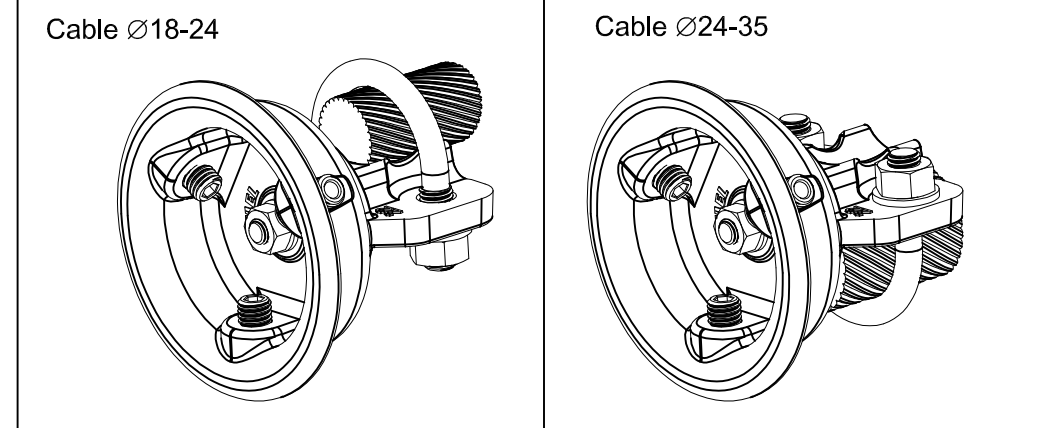

Cable 18DIA to 24 assembly
 Assemblage pour cable Ø18 à 24

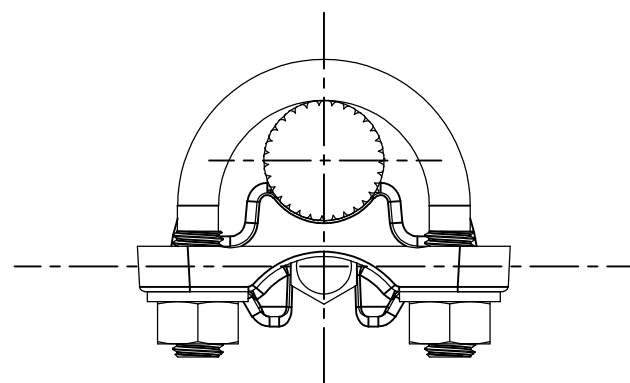

Cable 24DIA to 35 assembly
 Assemblage pour cable Ø24 à 35

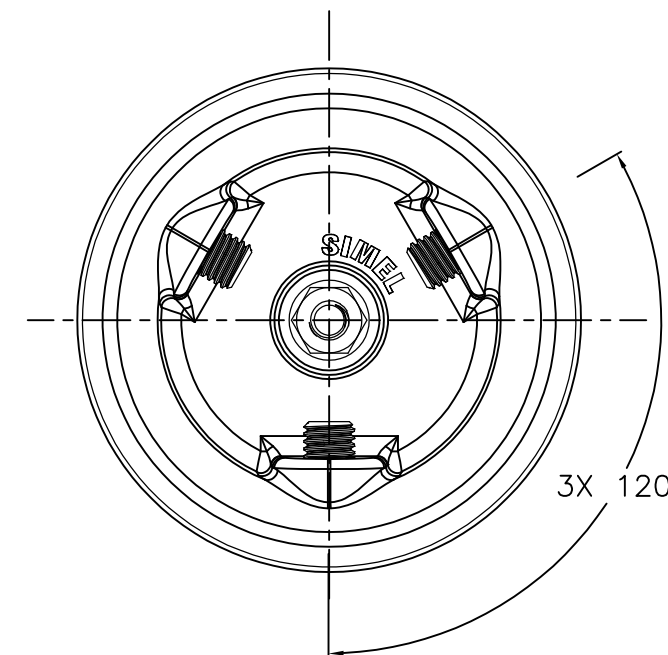
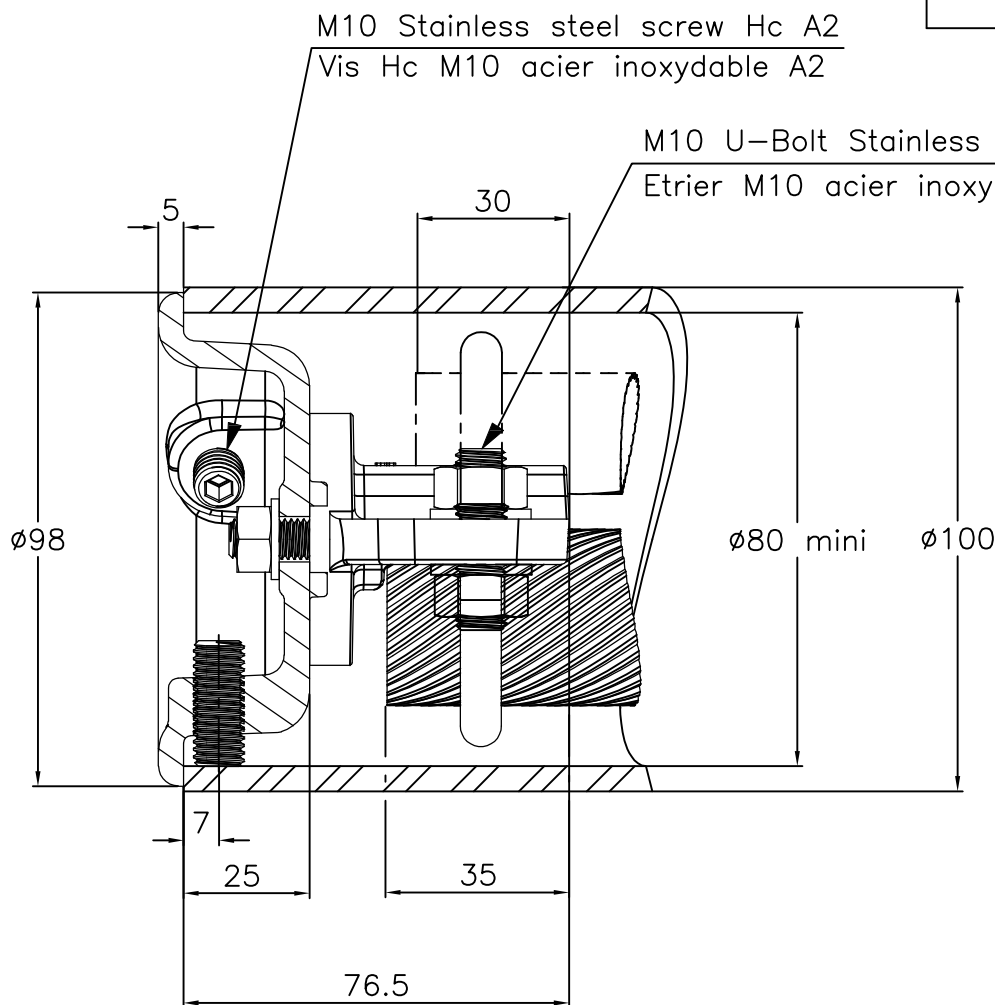
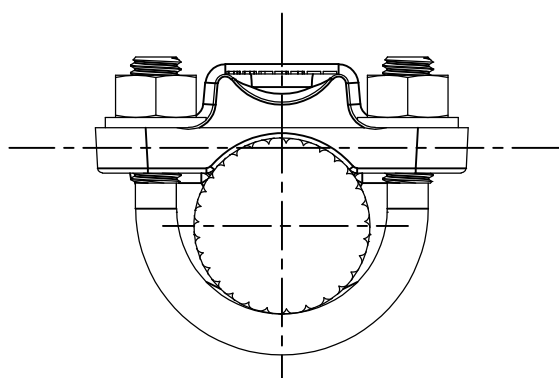

ITEM:.....

THIS DRAWING IS A CONTROLLED DOCUMENT.		DWN	10-Mar-15		STE TE Connectivity
		CHK	-		
		APVD	-		
		PRODUCT SPEC	108-69090-001		
DIMENSIONS: mm		TOLERANCES UNLESS OTHERWISE SPECIFIED:		NAME	
		0 PLC	± -	END CAP CABLE HOLDER BOUCHON PLAT PORT CABLE 5 TABPC 82 T100 18/35 (OPC 100)	
		1 PLC	± -		
		2 PLC	± -		
		3 PLC	± -		
		4 PLC	± -	APPLICATION SPEC	
		ANGLES	± -	SIZE	
MATERIAL		FINISH		CAGE CODE	
				DRAWING NO	
				RESTRICTED TO	
				-	
				WEIGHT	
				0.42 kg	
				A3 00779	
				C=2301086	
				CUSTOMER DRAWING	
				SCALE	
				3/4	
				SHEET	
				1 OF 1	
				REV	
				B	