

REVISIONS					
P	LTR	DESCRIPTION	DATE	DWN	APVD
A1	ECN-23-208938	TE STANDARD	19APR2023	LG	AM
A1	ECN-24-260762	MECHANICAL LIFE ADDED	15APR2024	KS	RB

NOTES
Bemerkungen

- 1 TE-CONNECTIVITY ORDER-NUMBER
TE-Connectivity Bestellnummer
- 2 DO NOT SWITCH UNDER LOAD!
Nicht unter Last schalten!

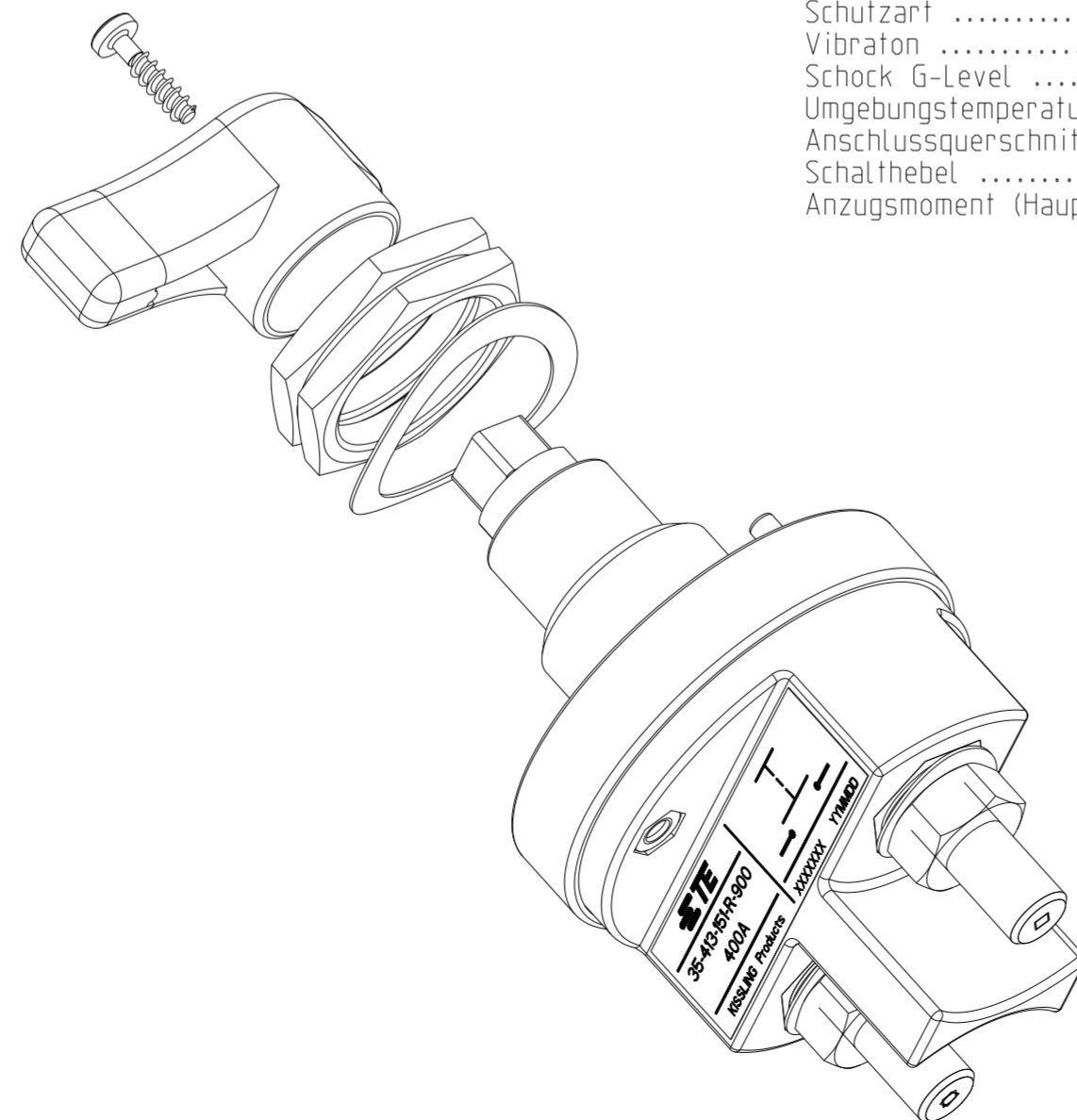
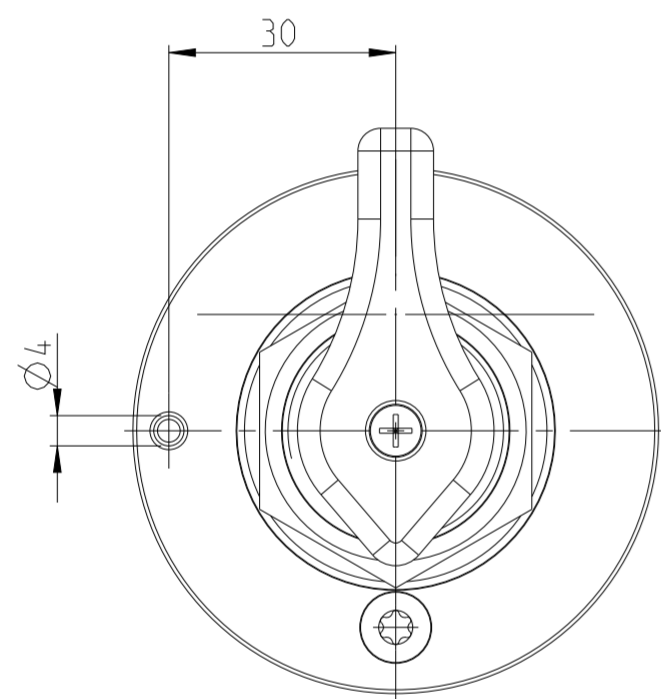
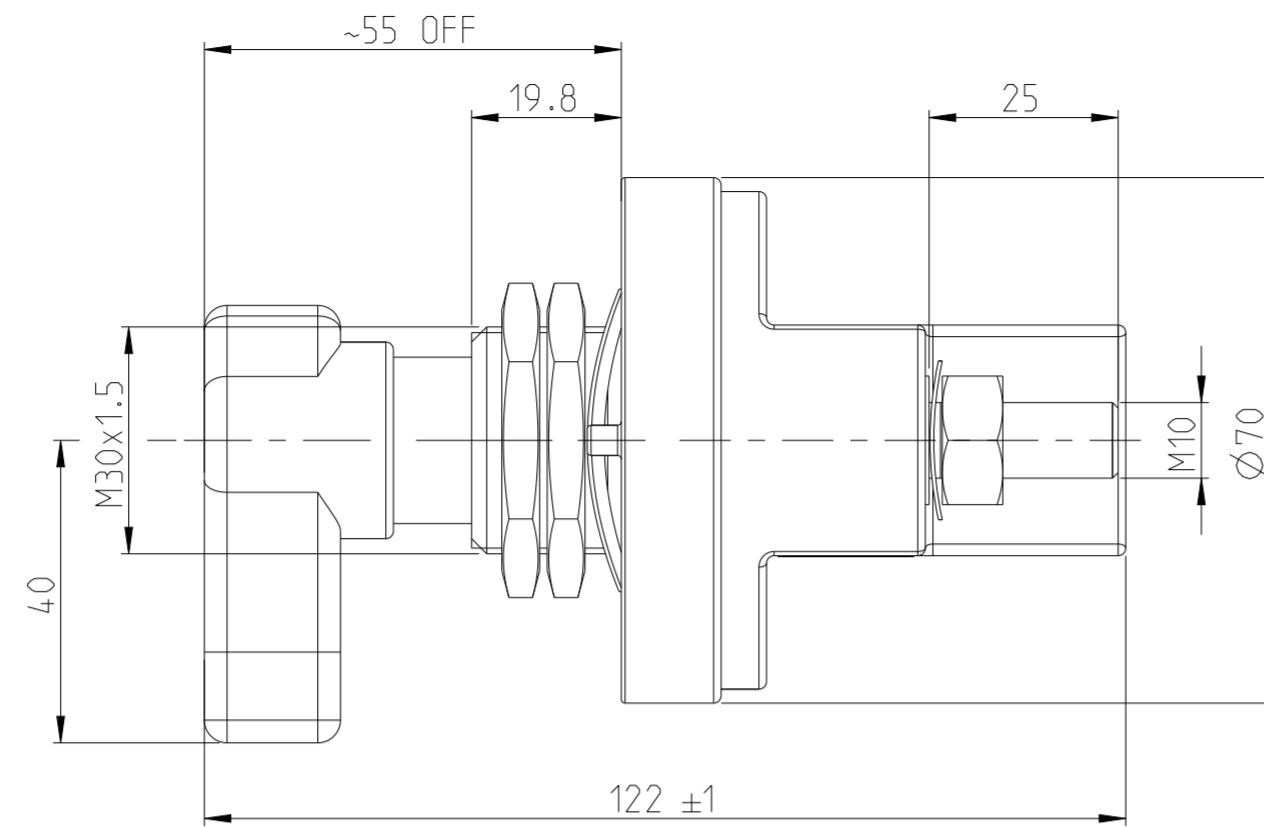
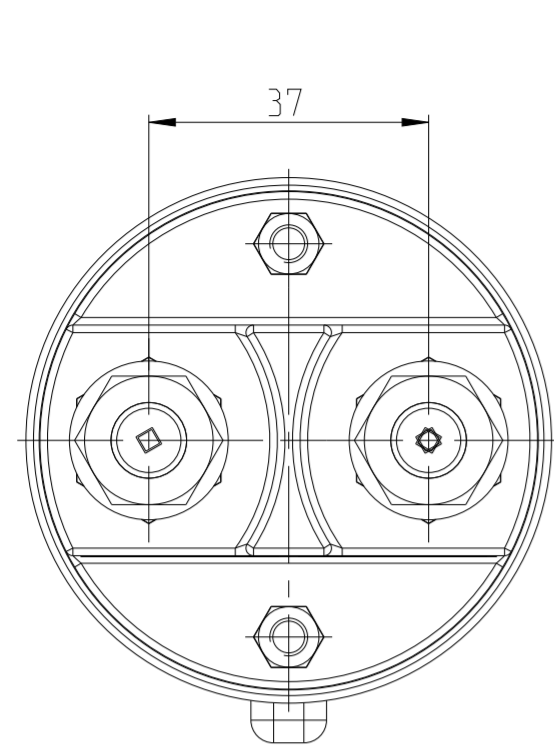

Technische Daten

Werkstoff: Haube	PA GF schwarz
Befestigungssockel	PA GF schwarz
Schalthebel	PA GF rot
Min. Isolationswiderstand	100 MOHM
Hochspannungsfestigkeit	1050V - 1 min.
Max. Kontaktspannungsabfall bei Nennlast..	150 mV
Betriebsspannung	bis 32 VDC
Dauerstrom	400 A
Ueberlast	1200A - 4 min.
.....	1600A - 1,5 min.
.....	2000A - 10 sec.
mech. Lebensdauer	min. 150000 Schaltspiele
Schutzart	IP 67 / IEC 529
Vibraton	4G / 50-2000 Hz
Schock G-Level	6G / 11 ms
Umgebungstemperatur	-40 °C bis +85 °C
Anschlussquerschnitt bei Nennlast	Min. 240 mm ²
Schalthebel	nicht abziehbar
Anzugsmoment (Hauptkontakte)	15 - 20 Nm

TECHNICAL DATA

CASE MATERIAL: COVER	PA GF BLACK
BASE PLATE	PA GF BLACK
SWITCH LEVER	PA GF RED
MIN INSULATION RESISTANCE	100 MOHM
DIELECTRIC WITHSTANDING VOLTAGE	1050V - 1 min.
MAX. CONTACT DROP DURING RESISTIVE LOAD..	150 mV
VOLTAGE	UP TO 32 VDC
DUTY RATING	400 A
OVERLOAD	1200 A - 4 min.
.....	1600 A - 1,5 min.
.....	2000 A - 10 sec.
MECHANICAL LIFE	MIN. 150000 CYCLES
SEALING	IP 67 / IEC 529
VIBRATION	4 G / 50-2000 Hz
SHOCK G-LEVEL	6G / 11 ms
TEMPERATURE RANGE	-40 °C TO +85 °C
WIRE SECTION (AT NOMINAL LOAD)	MIN. 240 MM ²
SWITCH LEVER	NOT REMOVEABLE
TORQUE (MAIN CONTACTS)	15 - 20 Nm

CIRCUIT
Schaltbild

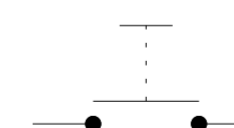

THIS DRAWING IS A CONTROLLED DOCUMENT.

DIMENSIONS: mm	TOLERANCES UNLESS OTHERWISE SPECIFIED: DIN ISO 2768 cL
0 PLC ±	1 PLC ±
2 PLC ±	3 PLC ±
4 PLC ±	ANGLES ±
MATERIAL	FINISH

DWN	25 JUN 2009
CHK	25 JUN 2009
APVD	29 JUN 2011
PRODUCT SPEC	
APPLICATION SPEC	
WEIGHT	
CUSTOMER DRAWING	

K1137081	1	A	BATTERY DISCONNECTOR 400A Batterietrennschalter 400A	422	1
TE ORDER-NO.	REV.		DESCRIPTION	WEIGHT (g)	ITEM NO.
TE Connectivity			NAME BATTERY DISCONNECTOR 400A Batterietrennschalter 400A		
SIZE	CAGE CODE	DRAWING NO.	RESTRICTED TO		
A2	00779	C-35-413-151-R-900	-		
SCALE			1:1	SHEET	1 OF 1
			REV A1		