

TÄ-Nr.	<h1>Battery Disconnecter 500A</h1>	Bl. 1 v. 1																																		
<p>Technical Data:</p> <table style="width:100%; border: none;"> <tr><td>Case Material: Cover</td><td>Vyncolit black</td></tr> <tr><td>Base Plate</td><td>PA GF black</td></tr> <tr><td>Key Plate</td><td>PA GF black</td></tr> <tr><td>Switch Lever Material</td><td>PA GF red</td></tr> <tr><td>Min. Insulation Resistance</td><td>100MΩ</td></tr> <tr><td>Dielectric Withstanding Voltage</td><td>1050V-1min</td></tr> <tr><td>Max. Contact Voltage Drop</td><td>150mV</td></tr> <tr><td>Voltage</td><td>up to 32VDC</td></tr> <tr><td>Continuous Rating</td><td>500A</td></tr> <tr><td>Overload.....</td><td>1500A 4min 2000A 1min 2500A-10sec</td></tr> <tr><td>Sealing</td><td>IP 67/ IEC 529</td></tr> <tr><td>Vibration</td><td>10G/ 18-500Hz</td></tr> <tr><td>Weight</td><td>340g/ 0.75 Pound</td></tr> <tr><td>Temperature Range</td><td>-40°C to +85°C</td></tr> <tr><td>Wire Selection (At Nominal Load)</td><td>min. 250mm²</td></tr> <tr><td>Key</td><td>not removeable lockable in "OFF" position not lockable in "ON" position</td></tr> <tr><td>Max. Torque (Main Contacts).....</td><td>18-22Nm</td></tr> </table>			Case Material: Cover	Vyncolit black	Base Plate	PA GF black	Key Plate	PA GF black	Switch Lever Material	PA GF red	Min. Insulation Resistance	100MΩ	Dielectric Withstanding Voltage	1050V-1min	Max. Contact Voltage Drop	150mV	Voltage	up to 32VDC	Continuous Rating	500A	Overload.....	1500A 4min 2000A 1min 2500A-10sec	Sealing	IP 67/ IEC 529	Vibration	10G/ 18-500Hz	Weight	340g/ 0.75 Pound	Temperature Range	-40°C to +85°C	Wire Selection (At Nominal Load)	min. 250mm ²	Key	not removeable lockable in "OFF" position not lockable in "ON" position	Max. Torque (Main Contacts).....	18-22Nm
Case Material: Cover	Vyncolit black																																			
Base Plate	PA GF black																																			
Key Plate	PA GF black																																			
Switch Lever Material	PA GF red																																			
Min. Insulation Resistance	100MΩ																																			
Dielectric Withstanding Voltage	1050V-1min																																			
Max. Contact Voltage Drop	150mV																																			
Voltage	up to 32VDC																																			
Continuous Rating	500A																																			
Overload.....	1500A 4min 2000A 1min 2500A-10sec																																			
Sealing	IP 67/ IEC 529																																			
Vibration	10G/ 18-500Hz																																			
Weight	340g/ 0.75 Pound																																			
Temperature Range	-40°C to +85°C																																			
Wire Selection (At Nominal Load)	min. 250mm ²																																			
Key	not removeable lockable in "OFF" position not lockable in "ON" position																																			
Max. Torque (Main Contacts).....	18-22Nm																																			
<table border="1" style="width:100%; border-collapse: collapse;"> <tr> <td style="width:10%; text-align: center;">Datum</td> <td style="width:10%; text-align: center;">Name</td> <td style="width:10%; text-align: center;">Allgemeintoleranz</td> <td style="width:10%; text-align: center;">Maßstab</td> <td style="width:10%; text-align: center;">Zeichnungs-Nr.:</td> <td style="width:40%;"></td> </tr> <tr> <td>Erstel.</td> <td>16.06.2010</td> <td>Mielk</td> <td rowspan="3" style="text-align: center; vertical-align: middle;">1:2</td> <td rowspan="3" style="text-align: center; vertical-align: middle;"></td> <td rowspan="3" style="text-align: center; vertical-align: middle;">35-514-231-R-901</td> </tr> <tr> <td>Bearb.</td> <td>07.08.2019</td> <td>Mielk</td> </tr> <tr> <td>Freig.</td> <td>14.08.2019</td> <td>Grind</td> </tr> <tr> <td colspan="4"></td> <td style="text-align: center;">Vers.Nr.:</td> <td></td> </tr> </table>			Datum	Name	Allgemeintoleranz	Maßstab	Zeichnungs-Nr.:		Erstel.	16.06.2010	Mielk	1:2		35-514-231-R-901	Bearb.	07.08.2019	Mielk	Freig.	14.08.2019	Grind					Vers.Nr.:											
Datum	Name	Allgemeintoleranz	Maßstab	Zeichnungs-Nr.:																																
Erstel.	16.06.2010	Mielk	1:2		35-514-231-R-901																															
Bearb.	07.08.2019	Mielk																																		
Freig.	14.08.2019	Grind																																		
				Vers.Nr.:																																

Für diese Zeichnung behalten wir uns das Urheberrecht gemäß DIN ISO 16016 vor

REVISIONS

P	LTR	DESCRIPTION	DATE	DWN	APVD
	A	TE STANDARD UPDATED	24MAY2024	KS	RB

NOTE:
Bemerkungen:

1 TE-CONNECTIVITY ORDER-NUMBER
TE-Connectivity Bestellnummer

2 DO NOT SWITCH UNDER LOAD!
Nicht unter Last schalten!

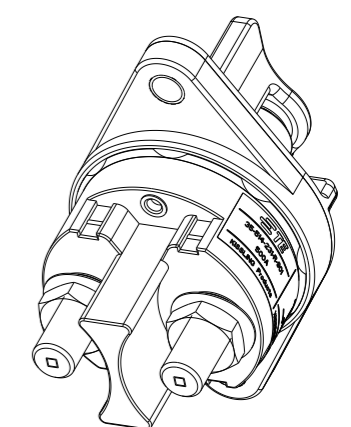

K1137209	1	A	BATTERY DISCONNECTOR 500A Batterietrennschalter 500A	1
TE ORDER-NO.	REV.		DESCRIPTION	ITEM NO

THIS DRAWING IS A CONTROLLED DOCUMENT.

<p>DIMENSIONS:</p> <p style="text-align: center;">mm</p>	<p>TOLERANCES UNLESS OTHERWISE SPECIFIED: DIN ISO 2768-CL</p> <table style="width:100%; border: none;"> <tr><td>0 PLC</td><td style="text-align: center;">±</td></tr> <tr><td>1 PLC</td><td style="text-align: center;">±</td></tr> <tr><td>2 PLC</td><td style="text-align: center;">±</td></tr> <tr><td>3 PLC</td><td style="text-align: center;">±</td></tr> <tr><td>4 PLC</td><td style="text-align: center;">±</td></tr> <tr><td>ANGLES</td><td style="text-align: center;">±</td></tr> <tr><td>FINISH</td><td></td></tr> </table>	0 PLC	±	1 PLC	±	2 PLC	±	3 PLC	±	4 PLC	±	ANGLES	±	FINISH	
0 PLC	±														
1 PLC	±														
2 PLC	±														
3 PLC	±														
4 PLC	±														
ANGLES	±														
FINISH															
MATERIAL	FINISH														

DWN N.Mielke 16JUN2010
 CHK N.Mielke 07AUG2019
 APVD U.Grindemann 14AUG2019
 PRODUCT SPEC
 APPLICATION SPEC
 WEIGHT
 CUSTOMER DRAWING

TE TE Connectivity

NAME
BATTERY DISCONNECTOR 500A
Batterietrennschalter 500A

SIZE	CAGE CODE	DRAWING NO	RESTRICTED TO
A3	00779	35-514-231-R-901	-
SCALE		SHEET	REV
5:1		1 OF 1	A