

SIZE	CABLE				REAR TERMINAL				CRIMPING TOOL	
	JACKET OUTSIDE DIA	DIELECTRIC OUTSIDE DIA (Max)	CENTER CONDUCTOR		KIT*	REAR TERMINAL ASSY	FERRULE	SHIELD CLIP	HAND TOOL	DIE ASSY
			AWG	DIA (Max)						
RG-58, 58A, 58B, or 58C	4.75-5.05 [.187-.199]	3.02 [.119]	22-20	0.953 [.0375]	422395-3	422397-1	328663	421260-2	402658	402951
RG-174 or 188	2.41-2.79 [.095-.110]	1.60 [.063]	26-24	0.64 [.025]	422392-2	422388-1	421427	421260-2	402659	402952
RG-178, 178A, or 196	1.83-2.16 [.072-.085]	1.60 [.063]	32-26	0.46 [.018]	422390-1	422386-1	328666	421260-2	402039	402953
RG-179A or 187	2.41-2.79 [.095-.110]	1.60 [.063]	32-26	0.46 [.018]	422392-1	422386-1	328666	421260-2	402660	402954
RG-180, 180A, or 195	3.48-3.94 [.137-.155]	3.02 [.119]	32-26	0.46 [.018]	422394-1	422396-2	328664	421260-2	402661	402955
RG-316	2.41-2.79 [.095-.110]	1.60 [.063]	26-24	0.64 [.025]	422392-5	422389-3	328666	421260-2	402660	402954
No. 22 or 20 Shielded	2.41-2.79 [.095-.110]	1.60 [.063]	22-20	0.953 [.0375]	422392-3	422389-1	328666	421260-2	402660	402954
	3.10-3.38 [.122-.133]	3.02 [.119]	22-20	0.953 [.0375]	422393-2	422397-1	330587	421260-2	402662	402956
	3.48-3.94 [.137-.155]	3.02 [.119]	22-20	0.953 [.0375]	422394-3	422397-1	328664	421260-2	402661	402955
No. 26, 24 or 22 Shielded	1.83-2.16 [.072-.085]	1.60 [.063]	26-22	0.953 [.0375]	422392-3	422389-1	328666	421260-2	402039	402953
	1.83-2.16 [.072-.085]	1.60 [.063]	26-22	0.74 [.029]	422391-1	422387-1	328666	421260-2	402039	402953
	3.48-3.94 [.137-.155]	3.02 [.119]	26-22	0.74 [.029]	422394-2	422398-1	328664	421260-2	402661	402955
	4.75-5.05 [.187-.199]	3.02 [.119]	26-22	0.74 [.029]	422395-2	422398-1	328663	421260-2	402658	402951
No. 32, 30, 28, or 26 Shielded	3.10-3.38 [.122-.133]	3.02 [.119]	32-26	0.46 [.018]	422393-1	422396-1	330587	421260-2	402662	402956
	4.75-5.05 [.187-.199]	3.02 [.119]	32-26	0.46 [.018]	422395-1	422396-1	328663	421260-2	402658	402951

* KIT INCLUDES REAR TERMINAL ASSY, FERRULE, AND SHIELD CLIP

90-439

Figure 1

1. INTRODUCTION

This instruction sheet supersedes IS 398010 and provides instructions on the assembly of the AMP Patchboard Rear Terminal Kits listed in Figure 1. These kits are recommended for making shielded

single-lead patchcords for AMP coaxial patchboard systems. Read this material thoroughly before starting assembly.

NOTE

Dimensions on this sheet are in metric units [with U.S. customary units in brackets].

2. DESCRIPTION (Figure 1)

Each kit includes a rear terminal assembly, a ferrule, and a shield clip. The rear terminal assembly consists of an outer shell, a dielectric, and a center contact.

3. ASSEMBLY PROCEDURE

Refer to the chart in Figure 1 and select the appropriate rear terminal kit according to the specified dimensions of the cable being used. Proceed as follows:

1. Slide ferrule onto cable – folded end first. Strip cable to the dimensions shown in Figure 2.

CABLE PREPARATION

SLIDE FERRULE ON CABLE – FOLDED END FIRST – THEN STRIP CABLE

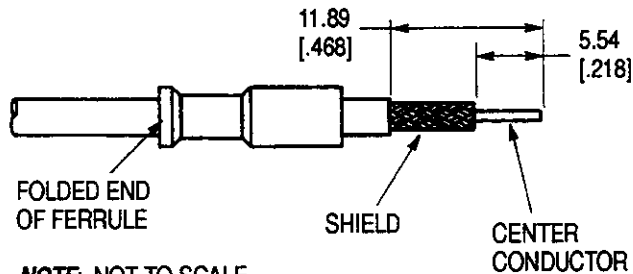

NOTE: NOT TO SCALE

Figure 2

90-440

NOTE

If production practice dictates, the ferrule may be installed after the stripping procedure. However, care must be used to prevent deformation of the shield.

2. Flare braid as shown in Figure 3. Insert center conductor into wire barrel portion of center contact as far as it will go. Make certain braid passes over and around support sleeve portion of shell.

CAUTION

Be sure center contact is fully extended (see Figure 3.)

3. Slide ferrule over braid until it butts against shell, or until it bottoms on braid.

The assembly is now ready to be crimped.

4. CRIMPING PROCEDURES

Refer to the chart in Figure 1 and determine the appropriate hand tool or die assembly to be used.

The crimping section of the hand tool (or die assembly) features three crimping die sets (an upper and lower die per set). One die set crimps the wire barrel portion of the center contact, one set crimps the braid section of the ferrule, and one set crimps the insulation section of the ferrule. All three crimps are made at the same time. See Figure 4.

A. Hand Tool Application (Figure 5)

The hand tools feature a CERTI-CRIMP* ratchet which assures full crimping of the assembly. Once engaged, the ratchet will not release until the tool handles have been FULLY closed. Proceed as follows:

1. Make sure ratchet is released — squeeze tool handles together and allow them to open FULLY. Position assembly in crimping section, making sure wire barrel crimping die set is aligned with rear terminal crimping ports.

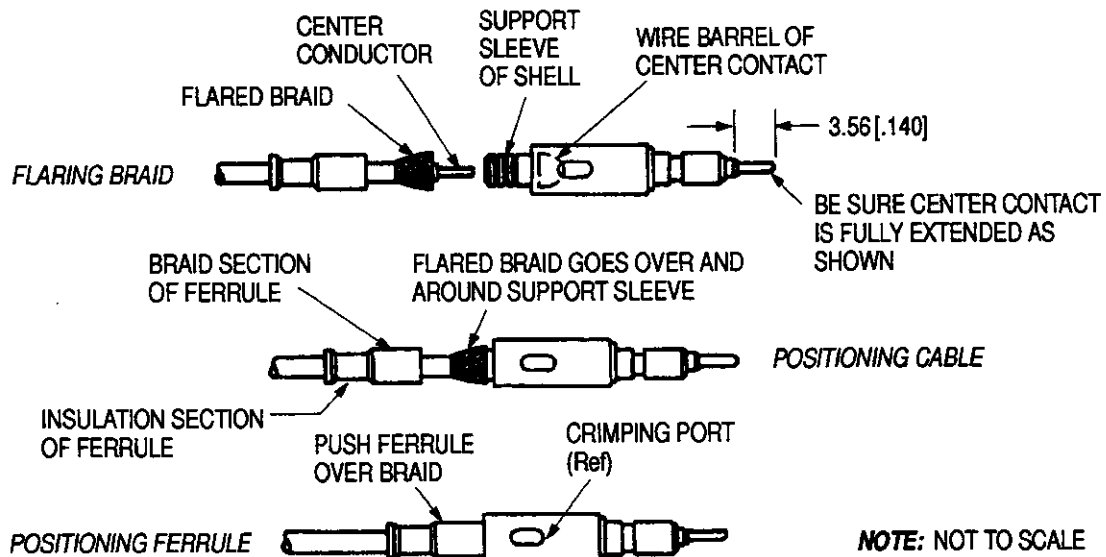

NOTE: NOT TO SCALE

Figure 3

90-441

DIE SETS
(Typical)

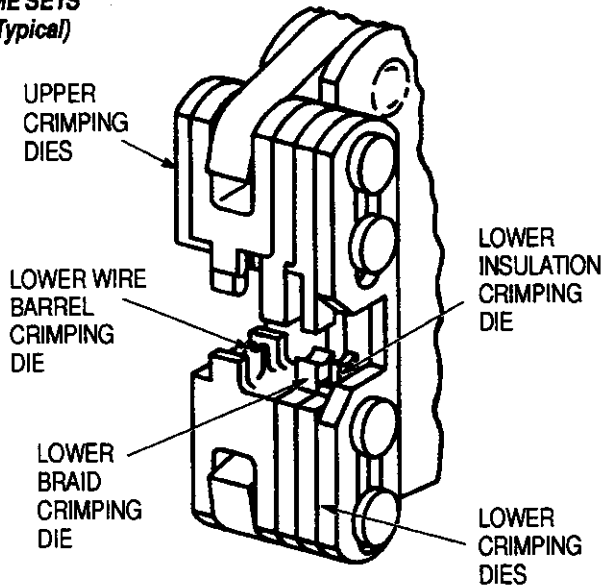
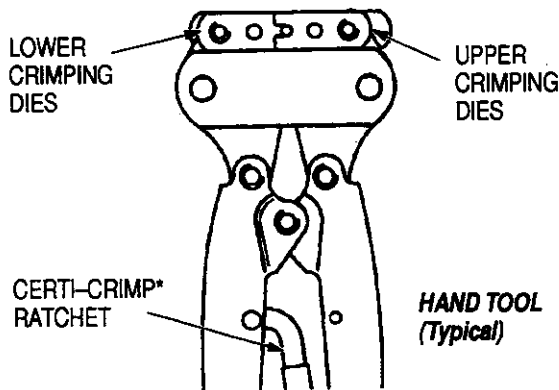

Figure 4

90-442

2. Push rear terminal DOWN so lower wire barrel crimping die enters lower crimping port, and braid section of ferrule is bottomed on lower braid crimping die.
3. Hold assembly in this position and squeeze tool handles together just enough so die sets hold assembly in place. Make certain upper wire barrel crimping die is aligned with upper crimping port.
4. Squeeze tool handles together until ratchet releases. Allow tool handles to open FULLY and remove crimped assembly from tool.
5. Check assembly to be sure it is properly crimped. Make certain wire barrel has been crimped without damaging crimping ports. Be sure cable or ferrule have not moved during crimping procedure. Test shield and center contact for conductivity.



PUSH REAR TERMINAL DOWN SO LOWER WIRE BARREL CRIMPING DIE ENTERS CRIMPING PORT

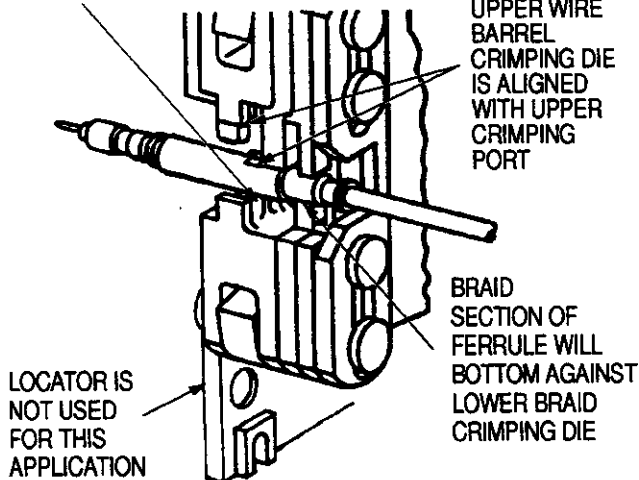

Figure 5

90-443

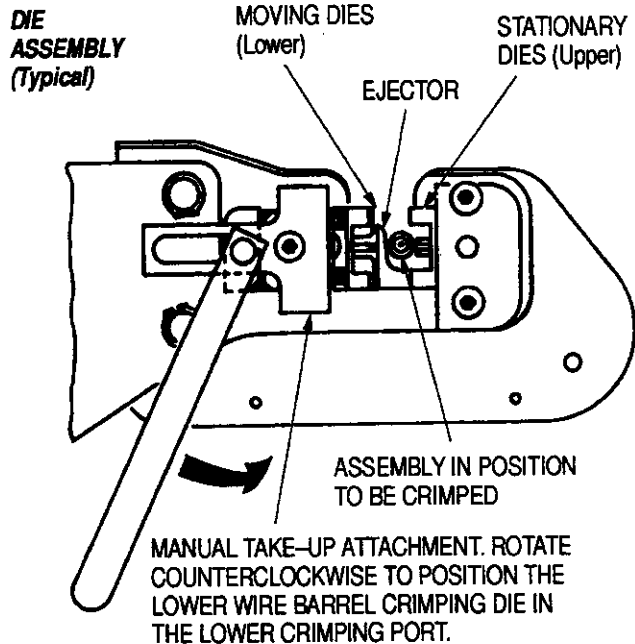

Figure 6

90-444

B. Die Assembly Application (Figure 6)

The die assemblies feature an ejector to facilitate removal of the crimped assembly. The die assemblies are designed for use in AMP Hand Crimping Tool 69710, 69710-1, or AMPORAPOWER* Pneumatic Tool 69365-2. Install appropriate die assembly according to instructions packaged with tool — AMP instruction sheet 408-2095 packaged with hand tool 69710, or AMP customer manual 409-1983, packaged with pneumatic tool 69365-2. Proceed as follows:

1. Open die assembly FULLY. Position assembly (to be crimped) between ejector and stationary (upper) crimping dies, making sure wire barrel crimping die is aligned with rear terminal crimping ports.

2. Push rear terminal UP so upper wire barrel crimping die enters upper crimping port, and braid section of ferrule is against upper braid crimping die.

NOTE

If using hand tool 69710, crimp the assembly according to Paragraph A, Hand Tool Application), Steps 3 through 5.

If using pneumatic tool 69365-2, continue with the following Steps 3 through 5.

3. Hold assembly in this position and rotate manual take-up lever COUNTERCLOCKWISE until moving (lower) wire barrel crimping die enters lower crimping port.

4. Depress pneumatic tool crimping button to crimp assembly. Release crimping button and remove crimped assembly from tool.

5. Check assembly to be sure it is properly crimped. Make certain wire barrel has been crimped without damaging crimping ports. Be sure cable or ferrule have not moved during crimping procedure. Test shield and center for conductivity.

5. ATTACHING SHIELD CLIP (Figure 7)

1. Place open side of shield clip against section of shell containing crimping ports.
2. Push clip DOWN until it snaps over shell.

3. Rotate clip until it seats in crimping ports. The assembly is now ready for use.

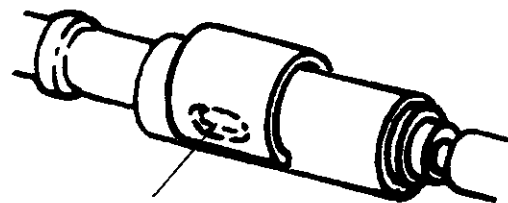
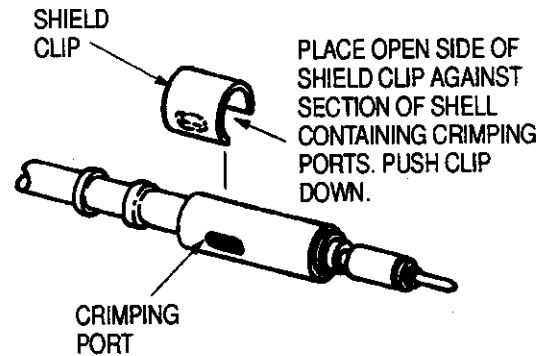

Figure 7

90-445