



**Material Evaluation for Positive Lock MK I**

**1. INTRODUCTION**

**1.1 Purpose**

Testing was performed on TE Connectivity's (TE) to evaluate the overall performance and stability of PN 880645-6 made from alternate C274 brass versus C268 versus C260 brass material.

**1.2 Scope**

This report covers the environmental, electrical and mechanical performance of the Positive Lock MKI that were submitted for testing. Testing was performed at the TE Connectivity Brazil Test Laboratory and external laboratory between July 2011 and January 2012. Detailed test data is on file and maintained at the TE Connectivity Brazil Test Laboratory under Test RL111252 and RL130502 and external test report Nr. 8612.

**1.3 Conclusion**

The Positive Lock MK I listed in paragraph 1.4 conformed to the electrical, environmental and mechanical performance requirements of the TE Brazil Test Plan – July 14, 2011.

**1.4 Test Specimens**

The test specimens submitted for testing are shown below in Table 1.

Table 1- Test Specimens

TEST SET		SPECIMEN DESCRIPTION – BREAKDOWN COMPONENT PART NUMBERS AS APPLICABLE TO PURPOSE OF TEST	
ID	QTY	PART NUMBER & REV. OR OTHER UNIQUE ID	LIST ATTRIBUTES APPLICABLE TO PURPOSE OF TEST (PLATING, BASE METAL, CONDUCTOR TYPE/SIZE, TOOLING,
1.1	90	880645-6 Rev B1 C260/Std Sn	Positive Lock MK I, 2,50 mm2
1.2	90	880645-6 Rev B1 C268/Std Sn	
1.3	90	880645-6 Rev B1 C272/274/Std Sn	
1.4	90	154717-3 Rev AR1 C260/Std Sn	Positive Lock MK I 4,00 mm2
1.5	90	154717-3 Rev AR1 C268/Std Sn	
1.6	90	154717-3 Rev AR1 C272/274/Std Sn	
1.7	75	62627-3 Rev P1	Test TAB Faston .250 series

Note 1: Rec terminals stamped with brass alloy 260 (actual raw material from production), brass alloy 268 (proposed raw material) and brass alloy 272/274 (proposed raw material).

**1.5 Test Sequence**

The test specimens identified in paragraph 1.4 were subjected to the tests in appendix 1 (end of the report).

**1.6 Environmental Conditions**

Unless otherwise stated, the following environmental conditions prevailed during testing:

Temperature: 18°C to 28°C  
Relative Humidity: 45% to 70%

## 2. SUMMARY OF TESTING

### 2.1 Initial Visual Examination

All specimens submitted for testing were representative of normal production lots. Where specified, specimens were visually examined and no evidence of physical damage detrimental to product performance was observed.

### 2.2 Mechanical Tests

- a) **Unlocked TAB / REC first insertion force** – All measurements had values in accordance with TE specification 108-20051, revision B. See table 2 for summary results.

Table 2

Force in [N]	260 Alloy	268 Alloy	272/274 Alloy
<b>Maximum</b>	32.77	34.76	33.40
<b>Average</b>	27.52	30.62	30.50
<b>Minimum</b>	22.38	27.61	26.93

Requirement: 35 N maximum  
Conclusion: Pass

- b) **Unlocked TAB / REC first extraction force** (without locking feature) – All measurements had values in accordance with TE specification 108-20051, revision B. See table 3 for summary results.

Table 3

Force in [N]	260 Alloy	268 Alloy	272/274 Alloy
<b>Maximum</b>	22.45	21.97	24.56
<b>Average</b>	18.16	18.98	19.45
<b>Minimum</b>	12.35	16.77	16.67

Requirement: 6.7 N minimum  
Conclusion: Pass

- c) **Locked TAB / REC sixth extraction force** (without locking feature) – All measurements had values in accordance with TE specification 108-3017, revision D. See table 4 for summary results.

Table 4

Force in [N]	260 Alloy	268 Alloy	272/274 Alloy
<b>Maximum</b>	16.20	17.87	18.50
<b>Average</b>	10.51	13.41	12.75
<b>Minimum</b>	6.12	8.16	7.34

Requirement: 4.448 N minimum  
Conclusion: Pass

d) **Locked TAB / REC extraction force** (with locking feature) – All measurements had values in accordance with TE specification 108-20051, revision B. See table 5 for summary results.

Table 5

Force in [N]	260 Alloy	268 Alloy	272/274 Alloy
<b>Maximum</b>	123.6	119.2	117.2
<b>Average</b>	117.0	112.2	114.5
<b>Minimum</b>	113.8	107.9	110.3

Requirement: 70 N minimum

Conclusion: Pass

### 2.3 Environmental / Mechanical Tests

All specimens submitted for testing were submitted to a, b and c environmental conditions and after measurements were done.

a) **Temperature and Humidity Cycling** – They were done 10 continuous cycles with 25°C and 65°C. Each cycle lasted 24 hours. Samples tested were dried before. No evidence of physical damage detrimental to product performance was observed.

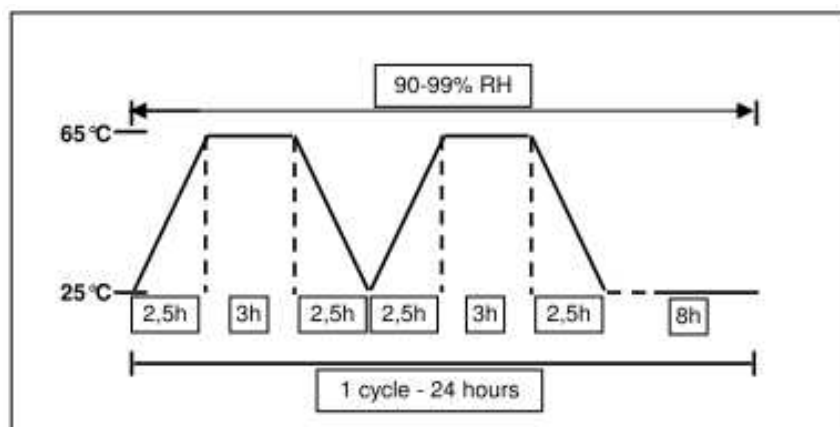

b) **Temperature Life** – No evidence of physical damage detrimental to product performance was observed.

c) **Thermal Shock** – No evidence of physical damage detrimental to product performance was observed.

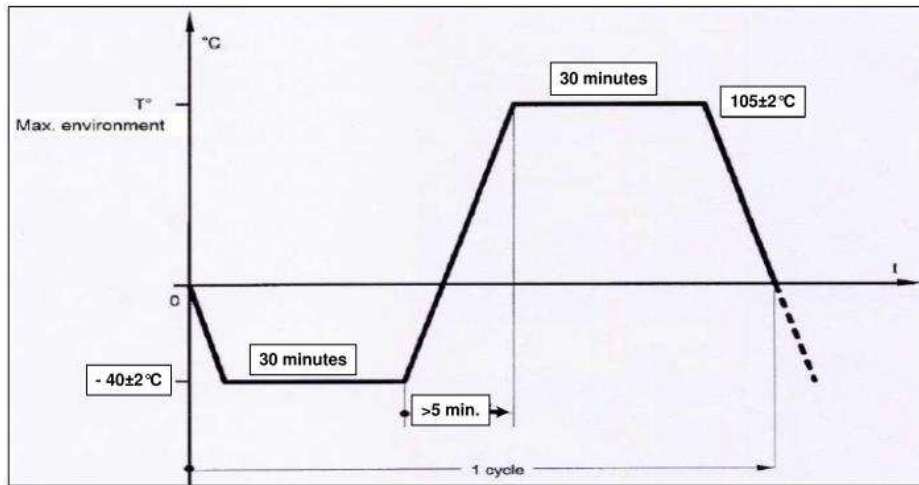

d) **Unlocked TAB / REC first insertion force** – All measurements had values informative. There is no a requirement specified to mechanical tests after environmental conditions. See table 6 for summary results.

Table 6

Force in [N]	260 Alloy	268 Alloy	272/274 Alloy
<b>2,50 mm<sup>2</sup> wire range</b>			
<b>Maximum</b>	46.25	50.00	49.71
<b>Average</b>	36.32	40.37	42.13
<b>Minimum</b>	28.94	32.49	33.67
<b>4,00 mm<sup>2</sup> wire range</b>			
<b>Maximum</b>	52.20	50.30	52.00
<b>Average</b>	40.30	39.10	42.68
<b>Minimum</b>	31.86	30.49	36.43

Requirement: Not specified  
 Conclusion: Informative

e) **Unlocked TAB / REC first extraction force** (without locking feature) – All measurements had values informative. There is no a requirement specified to mechanical tests after environmental conditions. See table 7 for summary results.

Table 7

Force in [N]	260 Alloy	268 Alloy	272/274 Alloy
<b>2,50 mm<sup>2</sup> wire range</b>			
<b>Maximum</b>	39.07	35.91	39.61
<b>Average</b>	28.89	28.26	28.26
<b>Minimum</b>	23.16	19.65	20.04
<b>4,00 mm<sup>2</sup> wire range</b>			
<b>Maximum</b>	32.03	39.56	34.88
<b>Average</b>	25.61	28.10	27.67
<b>Minimum</b>	18.42	21.84	20.37

Requirement: Not specified  
 Conclusion: Informative

**2.4 Mechanical Tests**

- a) **Wire Tensile Strength** – This is a cable retention force test in the terminal. See table 8 for summary results.

Table 8

Force in [N]	260 Alloy	268 Alloy	272/274 Alloy
<b>2,50 mm2 wire range</b>			
<b>Maximum</b>	231,0	228.1	222.7
<b>Average</b>	215.06	221.35	211.72
<b>Minimum</b>	198.6	211.9	192.2
<b>4,00 mm2 wire range</b>			
<b>Maximum</b>	500.3	485.6	483.1
<b>Average</b>	467.02	442.37	461.26
<b>Minimum</b>	428.7	411.5	442.9

**2.5 Environmental / Mechanical Tests**

- a) **Temperature and Humidity Cycling** – See item 2.3, a, on page 3 for description.
- b) **Temperature Life** – See item 2.3, b, on page 3 for description.
- c) **Thermal Shock** – See item 2.3, c, on page 3 for description.
- d) **Wire Tensile Strength** – See table 9 for summary results.

Table 9

Force in [N]	260 Alloy	268 Alloy	272/274 Alloy
<b>2,50 mm2 wire range</b>			
<b>Maximum</b>	233.5	240.3	240.3
<b>Average</b>	223.0	228.6	230.1
<b>Minimum</b>	207.0	212.3	213.8
<b>4,00 mm2 wire range</b>			
<b>Maximum</b>	593.5	595.5	609.7
<b>Average</b>	563.4	558.9	581.2
<b>Minimum</b>	544.0	536.0	548.4

**2.6 Environmental / Electrical Tests**

It was performed a several electrical and environmental tests intercalating low level contact resistance measurements, before and after, in order to evaluate modifications in the product performance.

- a) **Low level resistance** – All measurements were done according to TE specification 108-20051, revision B and had values in accordance with TE specification 108-20051, revision B. See table 10 for summary results.

Table 10

Contact Resistance [mΩ]	260 Alloy	268 Alloy	272/274 Alloy
<b>4,00 mm2 wire range</b>			
<b>Maximum</b>	0.72	0.95	0.68
<b>Average</b>	0.59	0.63	0.57
<b>Minimum</b>	0.52	0.54	0.50

Requirements: Maximum initial contact resistance = 2mΩ  
 Maximum contact resistance after conditioning tests = 3mΩ

Conclusion: Pass

**b) Temperature Rise Vs. Current** – All measurements were done according to EIA 364-70A, method II and UL310/2003. The highest test current level shall be the expected maximum operating current or the current level that produces a temperature rise of 30°C (UL 310). Consider the highest static expected value (X + 3σ). See table 11, 12 and 13 for summary results.

Table 11

Alloy 260 Samples	Current [A]												
	5.0	10.0	15.0	16.5	18.2	20.0	21.8	23.9	26.3	28.9	30.2	31.8	33.4
	ΔT [°C]												
<b>Min. ΔT value</b>	0.8	3.0	7.3	8.7	10.9	13.8	16.1	19.3	24.1	29.0	31.7	35.1	39.4
<b>Average (X)</b>	1.1	3.6	8.2	9.7	12.2	15.2	17.8	21.3	26.4	31.7	34.6	38.3	43.2
<b>Max. ΔT value</b>	1.4	4.1	8.9	10.4	13.0	16.3	19.0	22.7	28.0	33.5	36.5	40.7	45.6
<b>Std Deviation (σ)</b>	0.2	0.3	0.5	0.5	0.6	0.7	0.8	1.0	1.1	1.3	1.4	1.6	2.0
<b>X + 3σ</b>	1.7	4.5	9.6	11.1	14.0	17.4	20.2	24.2	29.8	35.6	38.8	43.0	49.1

Note: Maximum operating temperature and temperature rise graphs below are derived from table 11.

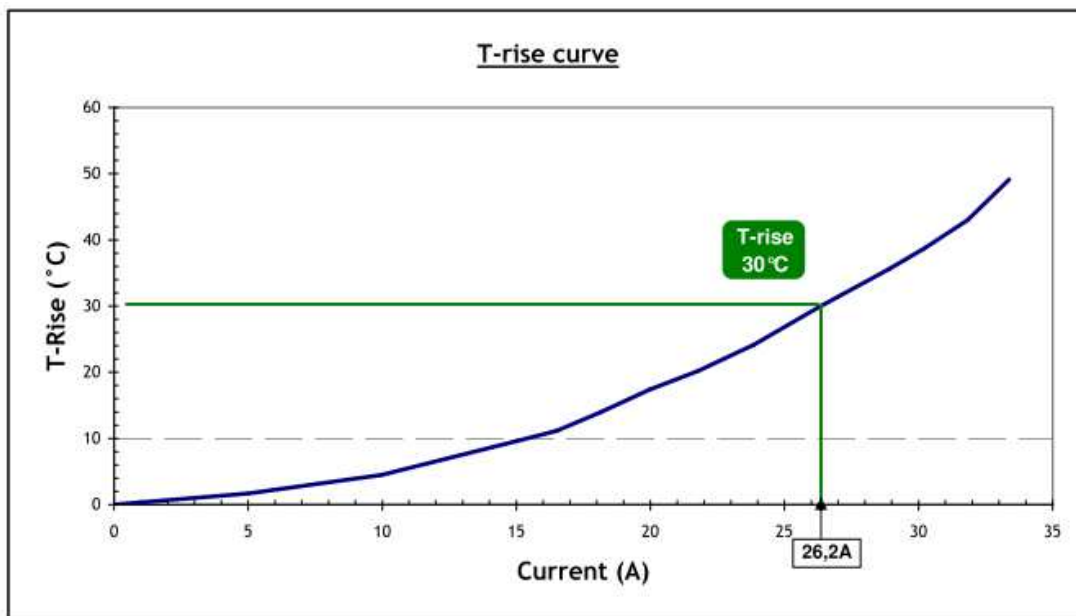

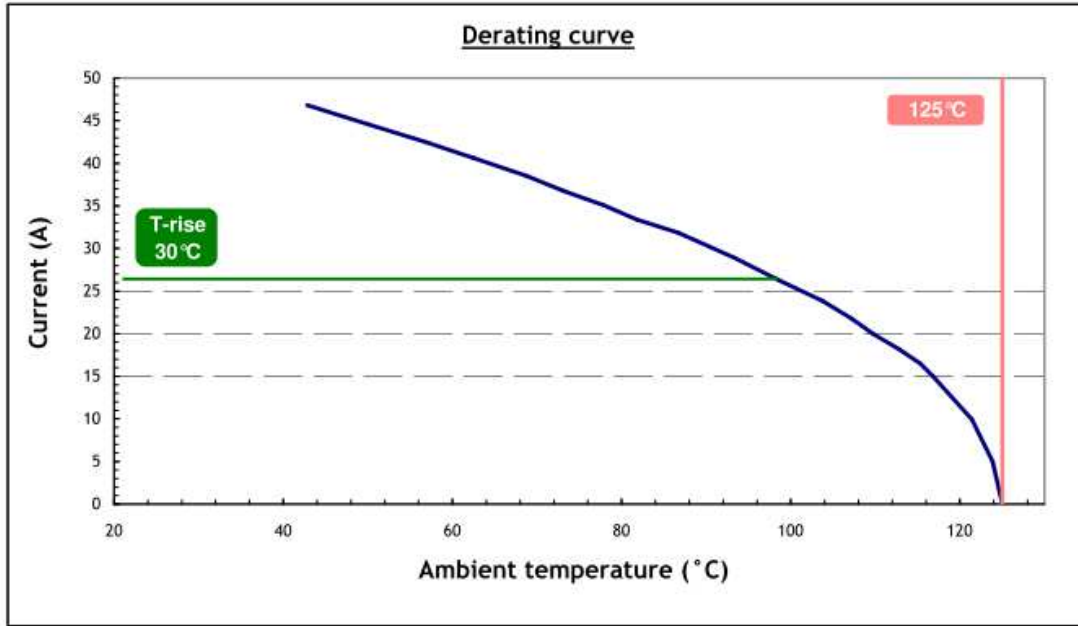
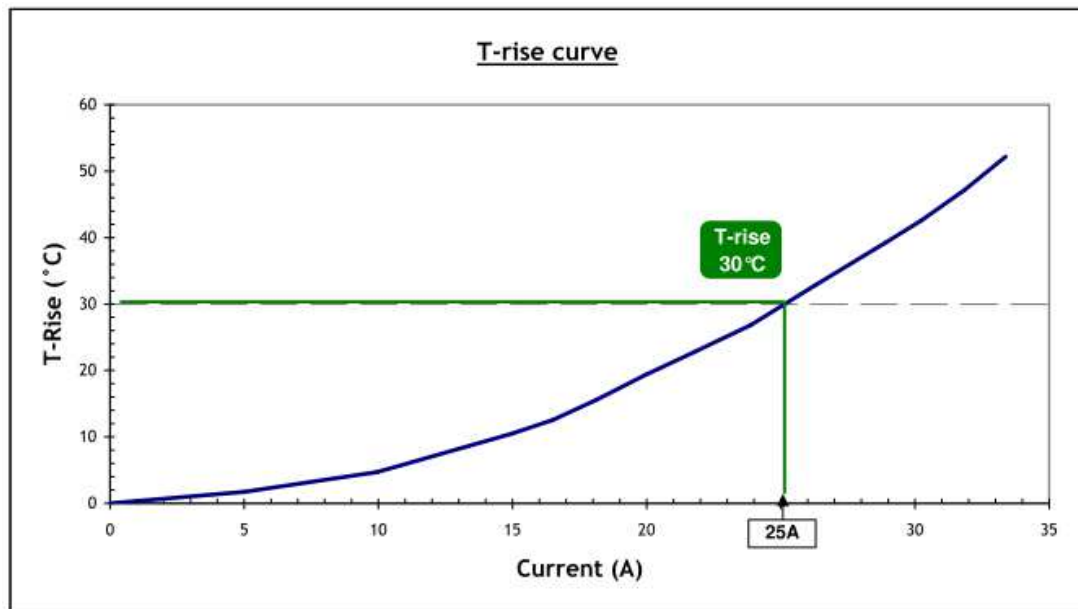

Table 12

Alloy 268 Samples	Current [A]													
	5.0	10.0	15.0	16.5	18.2	20.0	21.8	23.9	26.3	28.9	30.2	31.8	33.4	
	ΔT [°C]													
Min. ΔT value	1.0	3.3	7.6	9.1	11.4	14.5	17.1	20.6	25.4	30.8	33.6	37.6	42.1	
Average (X)	1.2	3.7	8.5	10.2	12.7	15.9	18.7	22.3	27.5	33.1	36.0	40.2	44.9	
Max. ΔT value	1.5	4.3	9.8	11.8	14.7	18.3	21.6	25.5	31.2	37.4	40.5	45.1	49.6	
Std Deviation (σ)	0.2	0.3	0.7	0.8	1.0	1.2	1.3	1.5	1.8	2.0	2.2	2.3	2.4	
X + 3σ	1.7	4.7	10.5	12.6	15.6	19.3	22.8	26.8	32.8	39.3	42.5	47.1	52.2	

Note: Maximum operating temperature and temperature rise graphs below are derived from table 12.



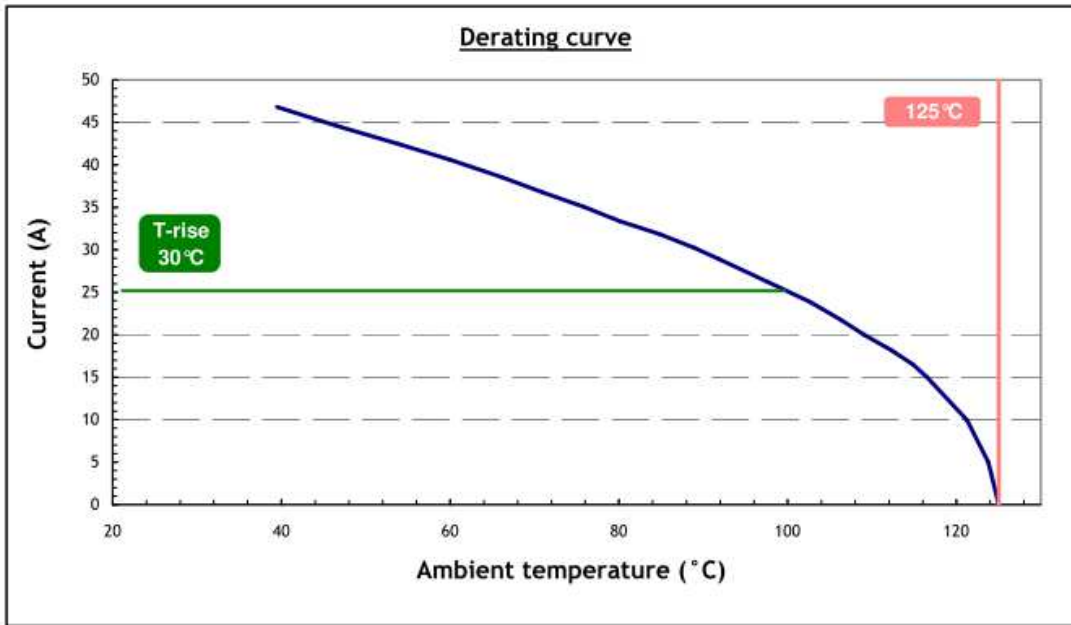
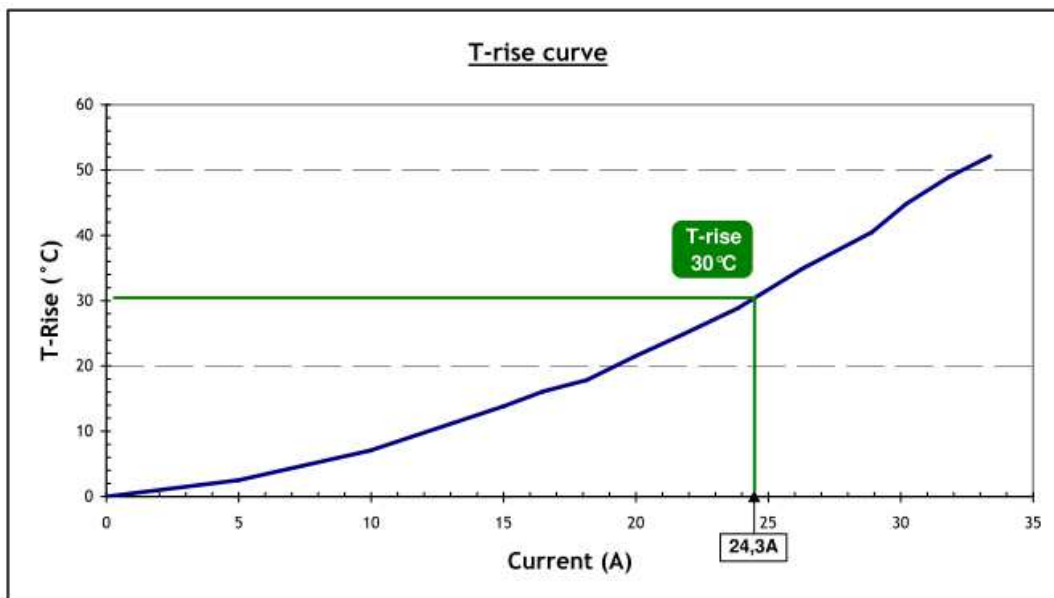

Table 13

Alloy 272 / 274 Samples	Current [A]												
	5.0	10.0	15.0	16.5	18.2	20.0	21.8	23.9	26.3	28.9	30.2	31.8	33.4
	ΔT [°C]												
Min. ΔT value	0.1	2.3	7.3	9.1	10.4	13.4	15.8	19.8	24.2	28.6	32.2	35.2	37.5
Average (X)	0.8	3.8	9.4	11.3	12.8	16.0	18.7	22.8	27.7	32.5	36.5	39.8	42.5
Max. ΔT value	2.2	6.4	12.8	14.9	16.5	19.8	22.8	26.5	31.8	36.8	41.0	44.3	46.9
Std Deviation (σ)	0.6	1.1	1.5	1.6	1.7	1.8	2.0	2.0	2.4	2.7	2.8	3.1	3.2
X + 3σ	2.5	7.0	13.8	16.1	17.8	21.5	24.8	28.9	34.9	40.5	44.9	49.0	52.1

Note: Maximum operating temperature and temperature rise graphs below are derived from table 13.





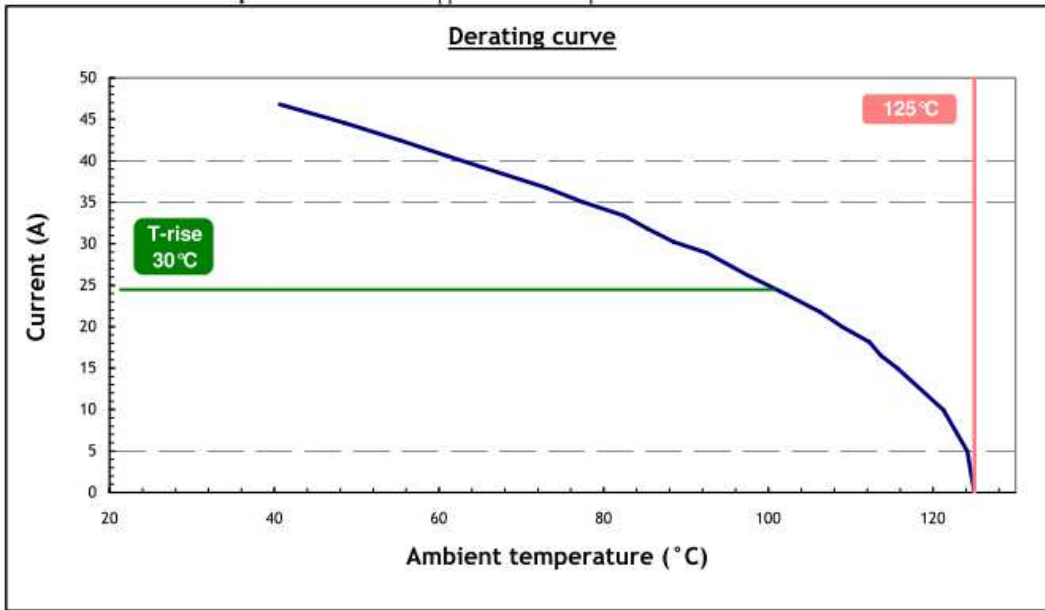

Conclusion:

Alloy	Maximum Current for 30°C ( $\Delta T$ )
260	26.2 A
268	25,0 A
272 / 274	24.3 A

c) **Low level resistance** – See item 2.6, a, to specifications. See table 14 for summary results.

Table 14

Contact Resistance [mΩ]	260 Alloy	268 Alloy	272/274 Alloy
	<b>4,00 mm<sup>2</sup> wire range</b>		
<b>Maximum</b>	0.73	0.96	0.65
<b>Average</b>	0.59	0.64	0.57
<b>Minimum</b>	0.55	0.54	0.51

Conclusion: Pass

d) **Current Cycling** – No evidence of physical damage detrimental to product performance was observed during or after current cycling. Refer to Tables 15 and 16 for a summary of the results.

Table 15

Contact Resistance [mΩ]	260 Alloy	268 Alloy	272/274 Alloy
	<b>Cycle 1</b>		
<b>Maximum</b>	1.15	1.12	1.14
<b>Average</b>	0.72	0.75	0.75
<b>Minimum</b>	0.62	0.59	0.57
	<b>Cycle 500</b>		
<b>Maximum</b>	1.23	1.08	1.31
<b>Average</b>	0.74	0.75	0.79
<b>Minimum</b>	0.62	0.60	0.57

Table 16

$\Delta$ Temperature [°C]	260 Alloy	268 Alloy	272/274 Alloy
	<b>Cycle 24</b>		
<b>Maximum</b>	49.21	51.18	51.12
<b>Average</b>	40.76	42.78	44.40
<b>Minimum</b>	36.37	38.15	37.63
	<b>Cycle 500</b>		
<b>Maximum</b>	58.13	52.01	55.22
<b>Average</b>	46.15	43.54	48.99
<b>Minimum</b>	42.78	39.29	44.78

Conclusion: Pass (only conditioning)

e) **Low level resistance** – See item 2.6, a, to specifications. See table 17 for summary results.

Table 17

Contact Resistance [mΩ]	260 Alloy	268 Alloy	272/274 Alloy
	<b>4,00 mm2 wire range</b>		
<b>Maximum</b>	1.08	0.92	1.11
<b>Average</b>	0.66	0.65	0.69
<b>Minimum</b>	0.56	0.54	0.52

Conclusion: Pass

f) **Temperature and Humidity Cycling** – See item 2.3, a, to specifications.

Conclusion: Pass (only conditioning)

g) **Low level resistance** – See item 2.6, a, to specifications. See table 18 for summary results.

Table 18

Contact Resistance [mΩ]	260 Alloy	268 Alloy	272/274 Alloy
	<b>4,00 mm2 wire range</b>		
<b>Maximum</b>	1.13	1.13	1.14
<b>Average</b>	0.76	0.83	0.78
<b>Minimum</b>	0.66	0.68	0.58

Conclusion: Pass

h) **Temperature Life** – See item 2.3, b, to specifications.

Conclusion: Pass (only conditioning)

i) **Low level resistance** – See item 2.6, a, to specifications. See table 19 for summary results.

Table 19

Contact Resistance [mΩ]	260 Alloy	268 Alloy	272/274 Alloy
	<b>4,00 mm2 wire range</b>		
<b>Maximum</b>	1.21	1.28	1.27
<b>Average</b>	0.82	0.86	0.82
<b>Minimum</b>	0.71	0.70	0.58

Conclusion: Pass

j) **Thermal Shock** –See item 2.3, c, to specifications.

Conclusion: Pass (only conditioning)

k) **Low level resistance** – See item 2.6, a, to specifications. See table 20 for summary results.

Table 20

Contact Resistance [mΩ]	260 Alloy	268 Alloy	272/274 Alloy
	<b>4,00 mm2 wire range</b>		
<b>Maximum</b>	1.23	1.74	1.31
<b>Average</b>	0.85	1.03	0.87
<b>Minimum</b>	0.67	0.70	0.62

Conclusion: Pass

l) **Vibration** – No apparent physical damage or discontinuities of one microsecond or greater occurred during testing. Test in accordance to EIA 364-28D, test condition II.

Conclusion: Pass (only conditioning)

m) **Low level resistance** – See item 2.6, a, to specifications. See table 20 for summary results.

Table 20

Contact Resistance [mΩ]	260 Alloy	268 Alloy	272/274 Alloy
	<b>4,00 mm2 wi1.28re range</b>		
<b>Maximum</b>	1.63	2.02	1.45
<b>Average</b>	1.17	1.28	1.08
<b>Minimum</b>	0.82	0.81	0.68

Conclusion: Pass

n) **Final Temperature Rise Vs. Current** – See item 2.6, b, to specifications. See table 21, 22 and 23 for summary results.

Table 21

Alloy 260 Samples	Current [A]												
	5.0	10.0	15.0	16.5	18.2	20.0	21.8	23.9	26.3	28.9	30.2	31.8	33.4
	ΔT [°C]												
Min. ΔT value	1.4	5.3	10.8	13.0	15.7	18.6	21.9	26.1	31.5	37.9	41.3		
Average (X)	2.3	6.5	13.5	16.5	19.9	23.7	27.7	33.0	39.6	47.4	51.7		
Max. ΔT value	2.6	7.4	15.2	19.0	23.0	27.0	31.8	37.8	45.5	54.3	59.5		
Std Deviation (σ)	0.4	0.8	1.6	2.0	2.4	2.9	3.4	4.0	4.6	5.4	5.9		
X + 3σ	3.4	9.0	18.2	22.5	27.3	32.2	37.8	44.9	53.5	63.7	69.5		

Note: Maximum operating temperature and temperature rise graphs below are derived from table 21.

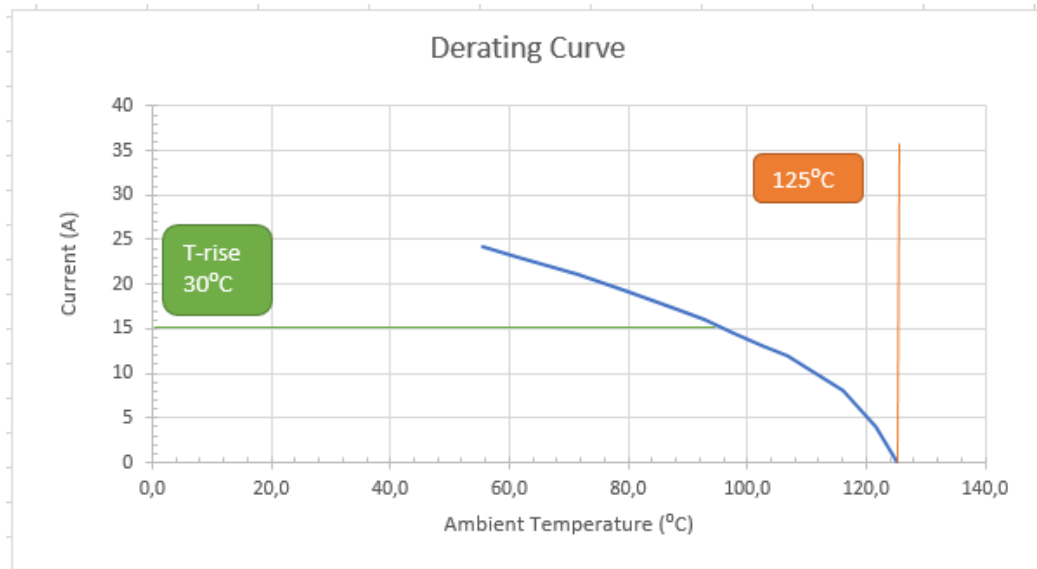
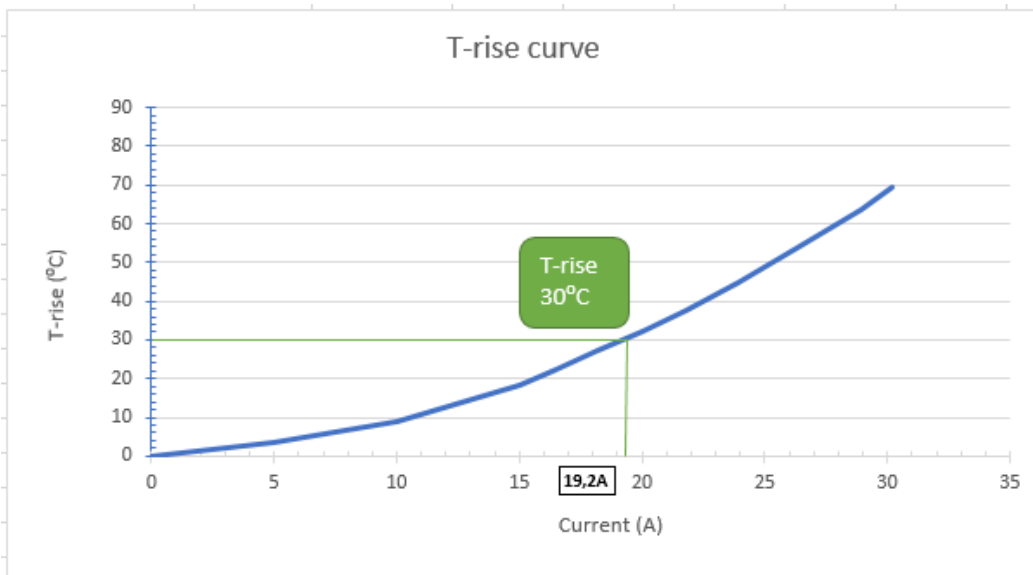

Table 22

Alloy 268 Samples	Current [A]													
	5.0	10.0	12.0	15.0	16.5	18.2	20.0	21.8	23.9	26.3	28.9			
	ΔT [°C]													
Min. ΔT value	1.6	5.9	8.3	12.6	15.1	18.2	21.9	25.9	30.8	36.6	44.1			
Average (X)	2.1	6.8	9.7	15.0	18.2	22.1	26.6	31.6	37.8	45.3	54.8			
Max. ΔT value	2.5	8.6	12.2	18.7	22.5	27.1	32.8	39.6	47.8	57.4	70.3			
Std Deviation (σ)	0.3	0.9	1.3	2.0	2.5	3.2	4.0	4.9	6.1	7.2	9.0			
X + 3σ	2.8	9.5	13.6	21.1	25.8	31.8	38.6	46.2	56.1	66.8	81.7			

Note: Maximum operating temperature and temperature rise graphs below are derived from table 22.

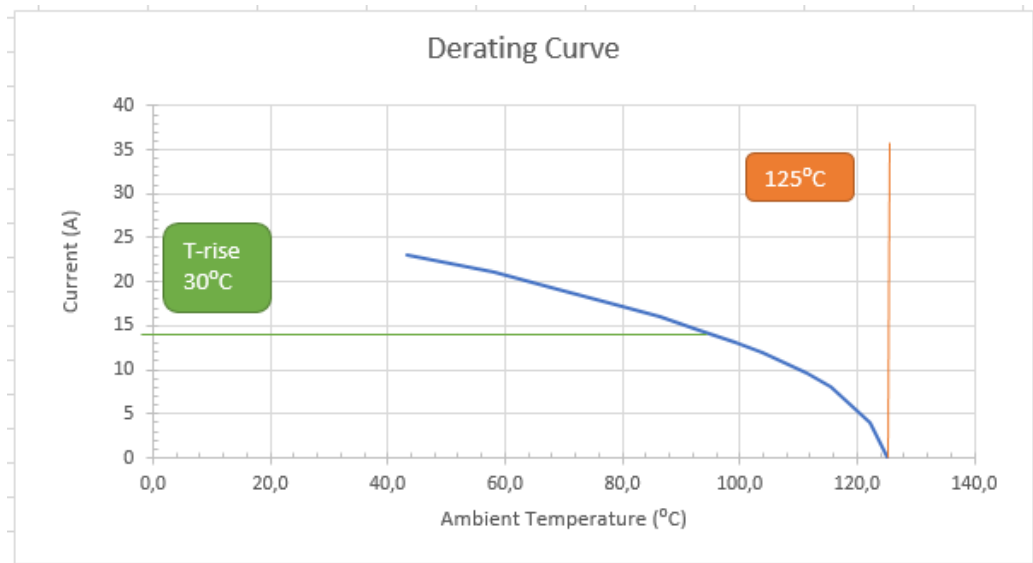
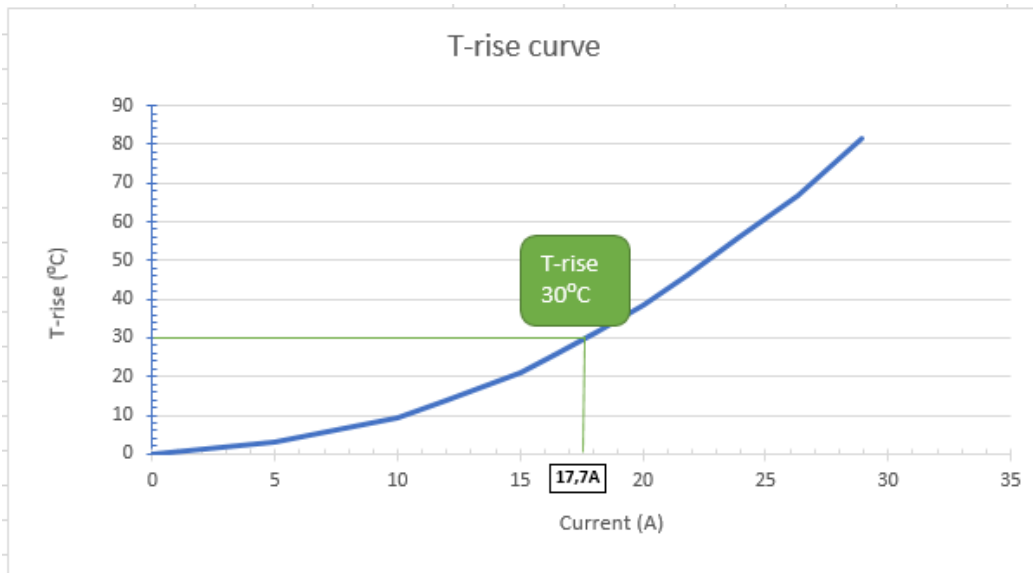
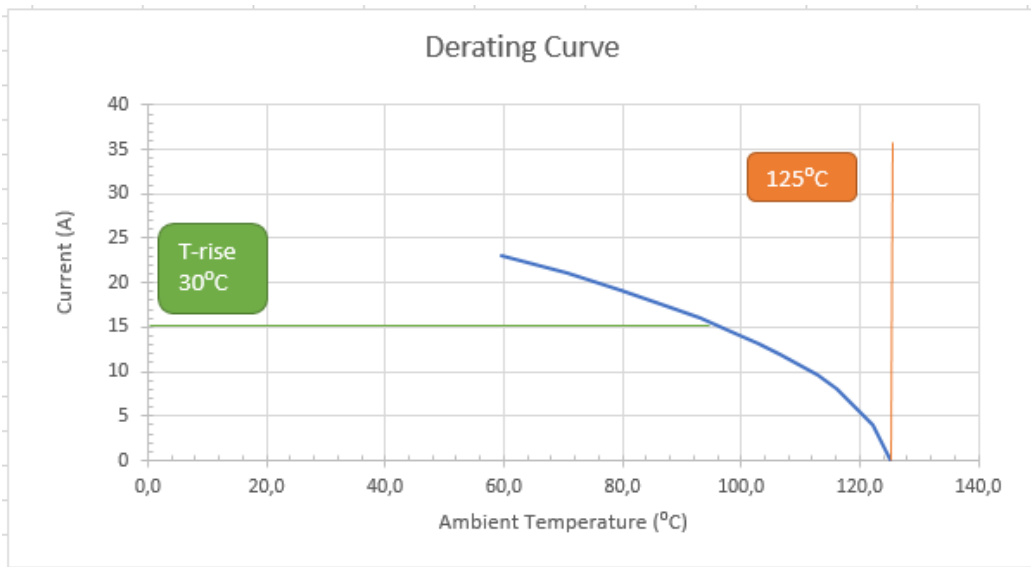
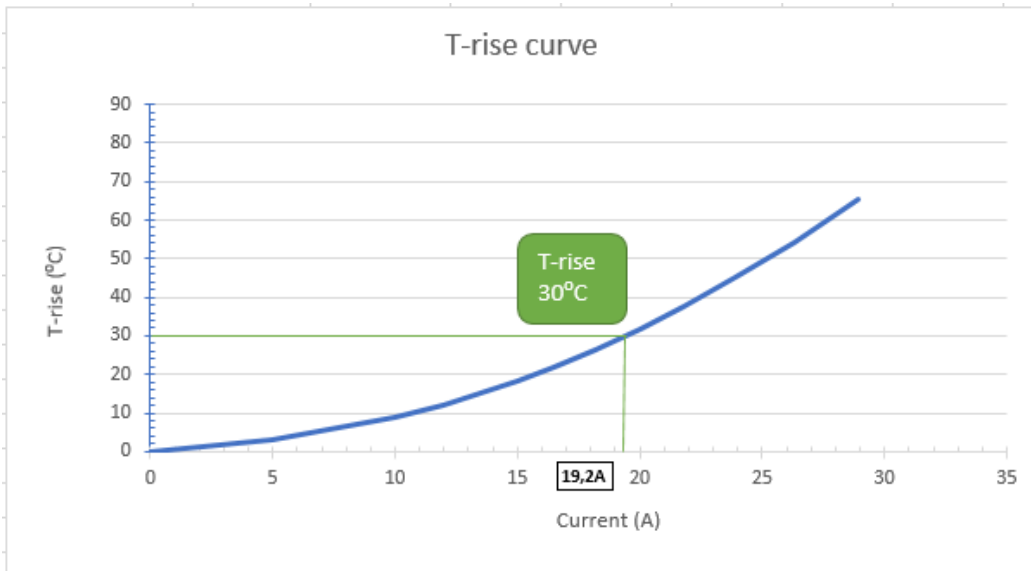

Table 23

Alloy 272/274 Samples	Current [A]														
	5.0	10.0	12.0	15.0	16.5	18.2	20.0	21.8	23.9	26.3	28.9				
	$\Delta T$ [°C]														
Min. $\Delta T$ value	1.9	5.5	7.8	12.0	14.4	17.4	20.8	24.7	28.7	34.6	41.2				
Average (X)	2.2	6.5	9.0	13.8	16.6	20.0	23.9	28.2	33.4	40.1	48.2				
Max. $\Delta T$ value	2.6	7.9	11.0	16.7	19.8	24.0	28.8	34.1	40.7	48.6	58.0				
Std Deviation ( $\sigma$ )	0.2	0.8	1.0	1.6	1.8	2.2	2.6	3.1	3.9	4.7	5.8				
X + 3 $\sigma$	2.9	8.7	12.2	18.4	21.9	26.6	31.8	37.7	45.2	54.2	65.5				

Note: Maximum operating temperature and temperature rise graphs below are derived from table 23.



Conclusion:

Alloy	Maximum Current for 30°C ( $\Delta T$ )
260	19.2 A
268	17.7 A
272 / 274	19.2 A

o) **Low level resistance** – See item 2.6, a, to specifications. See table 24 for summary results.

Table 24

Contact Resistance [mΩ]	260 Alloy	268 Alloy	272/274 Alloy
	<b>4,00 mm2 wi1.28re range</b>		
<b>Maximum</b>	1.64	2.17	1.99
<b>Average</b>	1.17	1.51	1.25
<b>Minimum</b>	0.76	0.88	0.73

Conclusion: Pass

### 2.7 Final Visual Examination

Specimens were visually examined and no evidence of physical damage detrimental to product performance was observed.

## 3 TEST METHODS

### 3.1 Initial Visual Examination

All specimens in this test package have been produced, inspected, and accepted as conforming to product drawing requirements, and made using the same core manufacturing processes and technologies as production parts.

### 3.2 Humidity Exposure

Specimens were subjected to 50°C at 90-95% Relative Humidity for 24 hours in an environmental chamber. Testing was performed in accordance with Test Specification EIA 364-31B, Method III.

### 3.3 Temperature Life

Specimens were subjected to 105°C for 200 hours in an air circulating oven. Testing was performed in accordance with Test Specification EIA 364-17B.

### 3.4 Thermal Shock

Test specimens were subjected to 25 cycles of Thermal Shock from -40°C to 105°C with 30 minutes dwells at each extreme. Testing was performed in accordance with EIA-364-32C, condition VIII.

### 3.5 Low Level Contact Resistance

Low Level Contact Resistance measurements were taken at a current level of 100 milliamperes maximum and 20 millivolts maximum open circuit voltage. Measurements were taken according to figure below that illustrates the measurement points. Testing was performed in accordance with Test Specification EIA 364-23A and TE specification 108-20051, revision B.

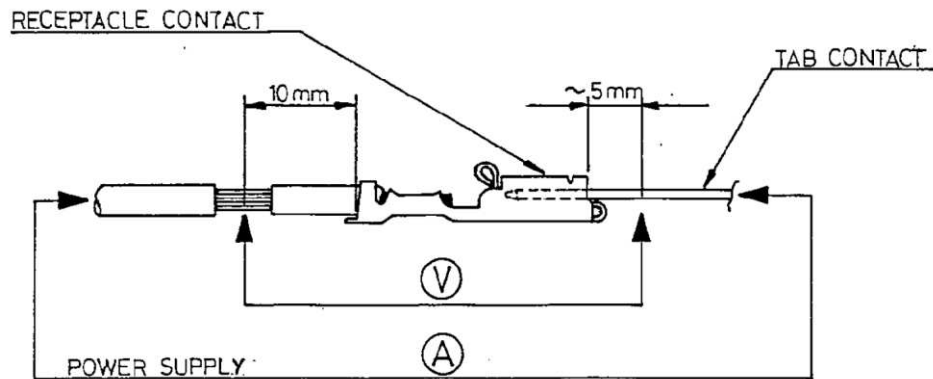

**Low Level Contact Resistance Measurement Points**

### 3.6 Temperature Rise Vs. Current

It was applied a current able to produce a temperature rise of approximately 5 to 10°C after thermal equilibrium occurs and stability was achieved. It was measured and recorded the specimen temperature, ambient temperature, test current and voltage drop.

### 3.7 Current Cycling

Testing consisted of 500 cycles of current cycling, with each cycle having current on for 45 minutes and current off for 15 minutes. Testing was performed in accordance with UL310, paragraph 6.

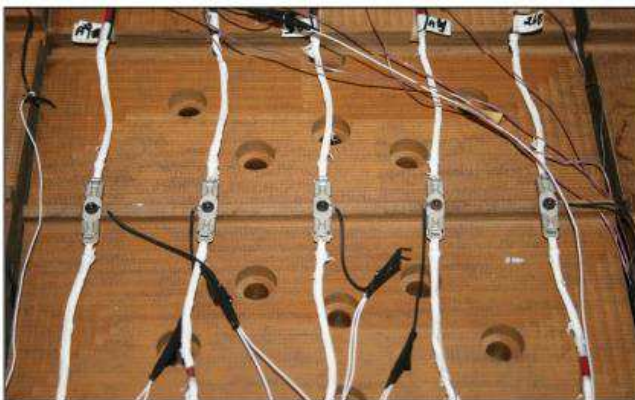



### 3.8 Temperature Life

Specimens were subjected to 105°C for 200 hours in an air circulating oven. Testing was performed in accordance with Test Specification EIA 364-17B.

### 3.9 Thermal Shock

Test specimens were subjected to 25 cycles of Thermal Shock from -40°C to 105°C with 30 minutes dwells at each extreme. Testing was performed in accordance with EIA-364-32C, condition VIII.

### 3.10 Vibration

The test specimens were subjected to a vibration test in accordance with specification EIA-364-28D. See Figures below for vibration setup photographs. The parameters of this test condition are specified by a random vibration spectrum with excitation frequency of 10, 15 and 500 Hertz (Hz). The test specimens were subjected to this test for 3 hours in each of the three mutually perpendicular axes, for a total test time of 9 hours per test specimen. Test performed in an external laboratory.

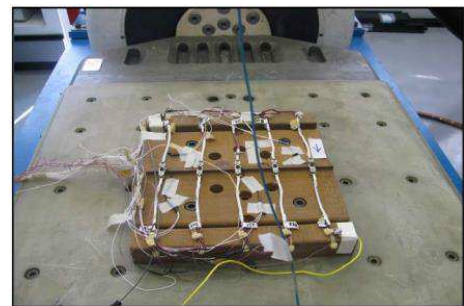

### 3.11 Final Visual Examination

Specimens were visually examined and no evidence of physical damage detrimental to product performance was observed.

## Appendix 1

### Test Sequence

#### Paragraph 2.2 – Mechanical Tests

- a) Unlocked TAB / REC first insertion force
- b) Unlocked TAB / REC first extraction force
- c) Locked TAB / REC sixth extraction force
- d) Locked TAB / REC extraction force

Paragraph 2.3 – Environmental / Mechanical Tests

- a) Temperature and Humidity Cycling
- b) Temperature Life
- c) Thermal Shock
- d) Unlocked TAB / REC first insertion force
- e) Unlocked TAB / REC first extraction force

Paragraph 2.4 – Mechanical Tests

- a) Wire Tensile Strength

Paragraph 2.5 – Environmental / Mechanical Tests

- a) Temperature and Humidity Cycling
- b) Temperature Life
- c) Thermal Shock
- d) Wire Tensile Strength

Paragraph 2.6 – Environmental / Electrical Tests

- a) Low level resistance
- b) Temperature Rise Vs. Current
- c) Low level resistance
- d) Current Cycling
- e) Low level resistance
- f) Temperature and Humidity Cycling
- g) Low level resistance
- h) Temperature Life Low level resistance
- i) Low level resistance
- j) Thermal Shock
- k) Low level resistance
- l) Vibration
- m) Low level resistance
- n) Final Temperature Rise Vs. Current
- o) Low level resistance

Revision Record					
Rev.	Date	Description	Edited	Checked	Approved
A	08-Feb-2019	Released	R. Gomes	W.Stefani	W. Stefani