

THIS DRAWING IS UNPUBLISHED.      RELEASED FOR PUBLICATION      2011

© COPYRIGHT 2011      Tyco Electronics AMP GmbH      ALL RIGHTS RESERVED.

LOC	DIST	REVISIONS					
A1	-	P	LTR	DESCRIPTION	DATE	DWN	APVD
			B1	ECR-12-013192	19JUL2012	MB	SB

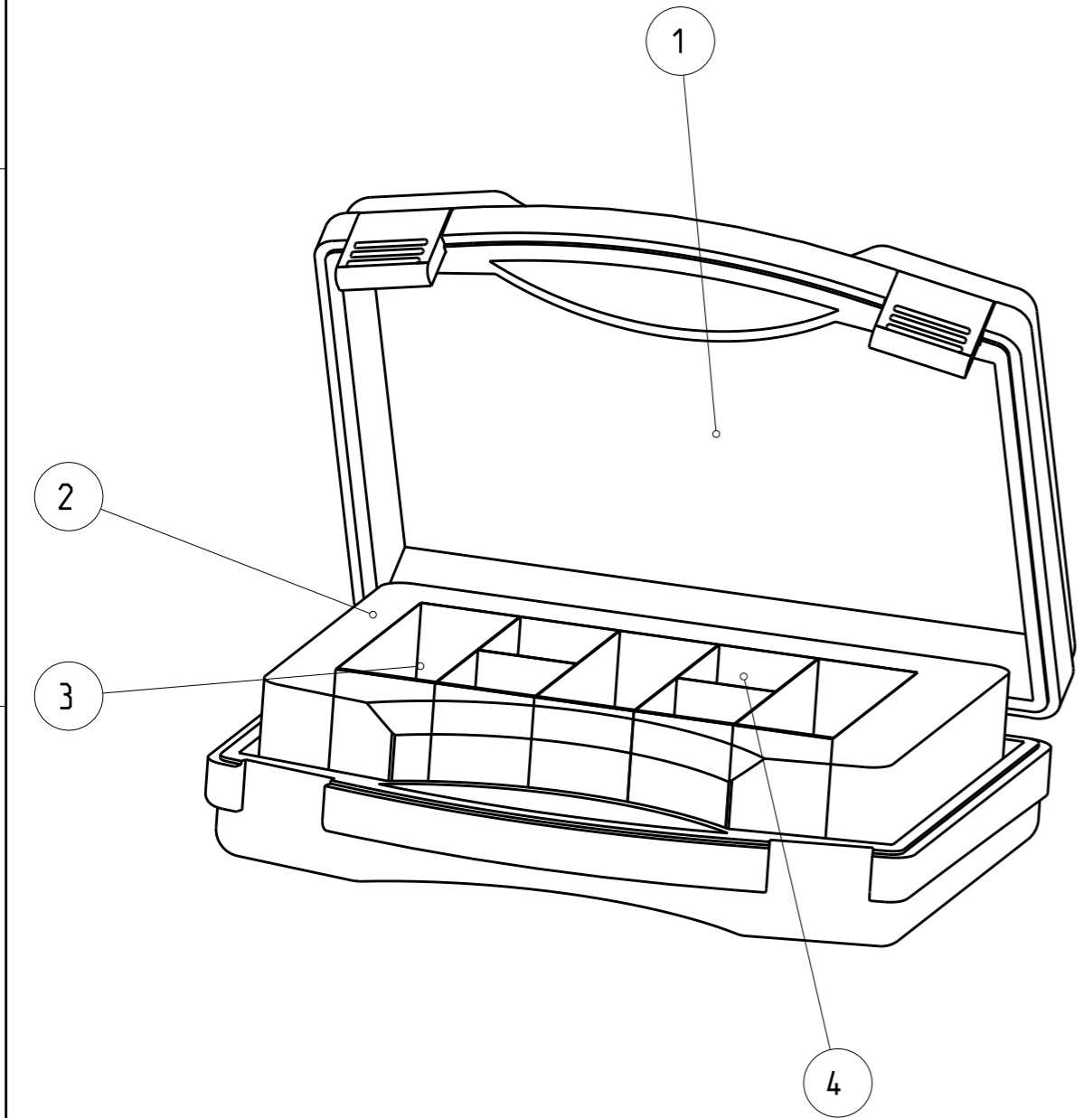

POS	QTY	FOR	TE/PN	REV	DESCRIPTION	WEAR	SPARE
1	1	A3	5-1579005-1	A	KOFFER SUITCASE BLANK	-	-
2	1	A4	539383-4	A	Koffereinlage case insert	-	-
3	3	A3	1-539383-1	A	FACH EINSATZ	-	-
4	4	A3	1-539383-0	A	FACH EINSATZ	-	-

THIS DRAWING IS A CONTROLLED DOCUMENT.		DWN RAGHAVENDRA 27SEP2011														
DIMENSIONS: mm		CHK KURT L 27SEP2011														
TOLERANCES UNLESS OTHERWISE SPECIFIED:		APVD SIEGERIED B 27SEP2011	NAME SUIT CASE													
<table border="0"> <tr><td>0 PLC</td><td>±</td></tr> <tr><td>1 PLC</td><td>±</td></tr> <tr><td>2 PLC</td><td>±</td></tr> <tr><td>3 PLC</td><td>±</td></tr> <tr><td>4 PLC</td><td>±</td></tr> <tr><td>ANGLES</td><td>±</td></tr> </table>		0 PLC	±	1 PLC	±	2 PLC	±	3 PLC	±	4 PLC	±	ANGLES	±	PRODUCT SPEC	-	
0 PLC	±															
1 PLC	±															
2 PLC	±															
3 PLC	±															
4 PLC	±															
ANGLES	±															
MATERIAL -		APPLICATION SPEC	-													
FINISH -		WEIGHT -	SIZE A3	CAGE CODE 00779												
		Customer Drawing	DRAWING NO C-539383-5	RESTRICTED TO -												
			SCALE 1:5	SHEET 1 OF 1												
				REV B1												