

REVISIONS				
P	LTR	DESCRIPTION	DATE	APVD
	A2	RETURN LOSS SPECIFICATION CORRECTED	02JUN2021	SS OW

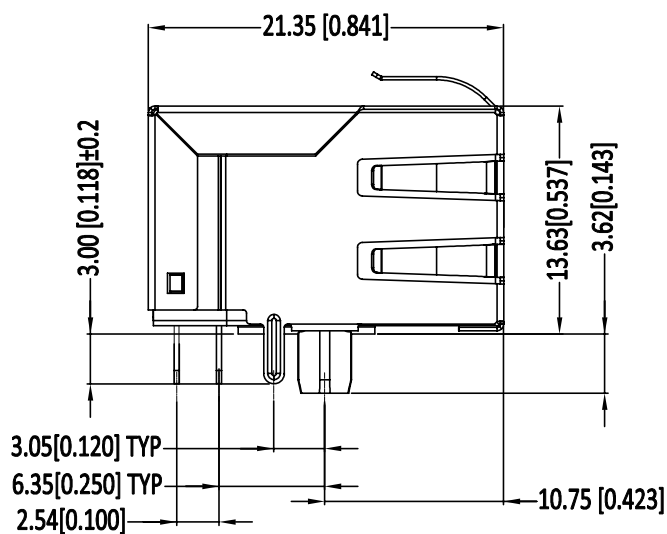

- 1 CONNECTOR MATERIAL:
 HOUSING: LCP BLACK UL94 V-0
 INSERT: LCP BLACK UL94 V-0
 SHIELD: BRASS
 SHIELD PLATING: NICKEL
 CONTACT: COPPER ALLOY
 CONTACT PLATING: SELECTIVE GOLD, MIN. 0.76µm (30µinch) IN CONTACT AREA
 OVER MIN. 1.27µm (50µinch) NICKEL
 SOLDER PIN PLATING: 3.05µm (120µinch) TIN OVER 1.27µm (50µinch) NICKEL
 OVER ALL
 SHIELDING PIN PLATING: NICKEL
- 2 PIN NOT ELECTRICALLY CONNECTED MAYBE OMITTED SEE ELECTRICAL CIRCUIT DIAGRAM FOR OMITTED PINS
- 3 RJ45 CAVITY DIMENSION CONFORM TO FCC PART 68
- 4 THE PART IS RECOMMENDED FOR REFLOW SOLDERING PROCESS PEAK SOLDERING: TEMPERATURE MAX. +260°C, MAX. 10s
- 5 OPERATING TEMPERATURE: T= -40°C TO +85°C
- 6 STORAGE TEMPERATURE: T= -40°C TO +85°C
- 7 UNLESS OTHERWISE SPECIFIED, SEE TABLE FOR ALL DIMENSIONS TOLERANCES
- 8 JACK CONFIGURATION: 1 x 1
 TAB DIRECTION: DOWN
- 9 AUTOMATED PLACEMENT: FOR FORCE-FREE ASSEMBLY WITHOUT THE ALIGNMENT FUNCTION WIDEN TO MIN. 3.40 mm DIAMETER
- 10 PACKAGING: TRAY ACCORDING TO PACKAGING SPECIFICATION 107-18116

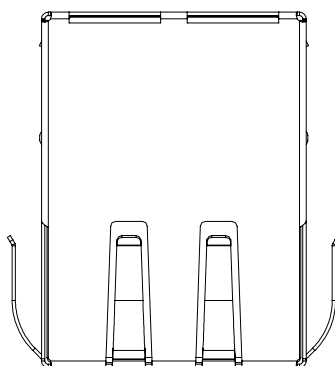
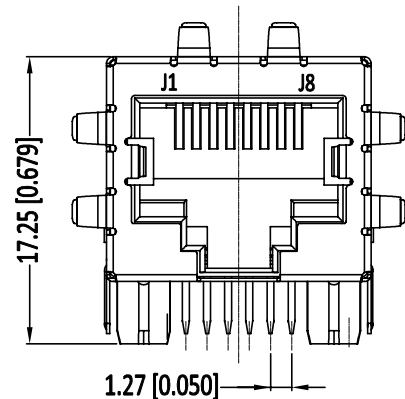
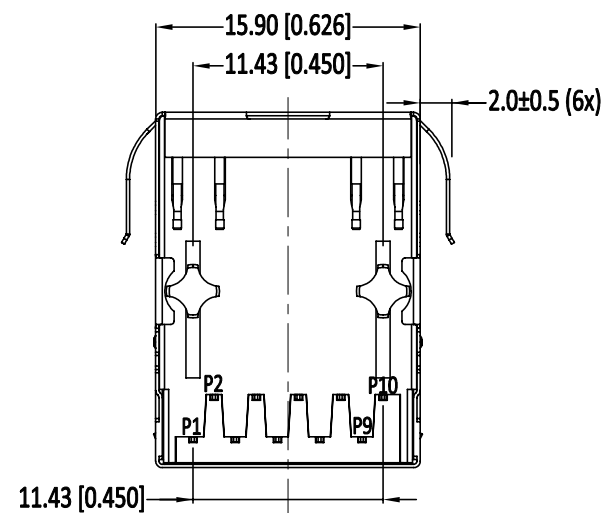
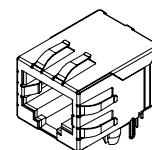

1:1

TABLE OF TOLERANCE (mm)	
RANGE	TOLERANCE
0-10	±0.15
>10-40	±0.25
>40-70	±0.30
>70	±0.40

THIS DRAWING IS A CONTROLLED DOCUMENT.		DWN GANESH C M 27AUG2016	TE Connectivity Ltd.																
		CHK FRANZ MUELLER 27AUG2016																	
		APVD MARTIN SZELAG 27AUG2016	NAME RJ45 JACK INT.MAG. 1Gb 1x1																
DIMENSIONS: mm [INCHES]		PRODUCT SPEC 108-94552																	
TOLERANCES UNLESS OTHERWISE SPECIFIED:		APPLICATION SPEC 114-94447																	
<table border="0"> <tr> <td>0 PLC</td> <td>± -</td> <td rowspan="4">7</td> </tr> <tr> <td>1 PLC</td> <td>± -</td> </tr> <tr> <td>2 PLC</td> <td>± -</td> </tr> <tr> <td>3 PLC</td> <td>± -</td> </tr> <tr> <td>4 PLC</td> <td>± -</td> <td></td> </tr> <tr> <td>ANGLES</td> <td>± -</td> <td></td> </tr> </table>		0 PLC	± -	7	1 PLC	± -	2 PLC	± -	3 PLC	± -	4 PLC	± -		ANGLES	± -		WEIGHT -	SIZE A3	CAGE CODE 00779
0 PLC	± -	7																	
1 PLC	± -																		
2 PLC	± -																		
3 PLC	± -																		
4 PLC	± -																		
ANGLES	± -																		
MATERIAL 1		FINISH 1	DRAWING NO C=7-2301994-1																
		CUSTOMER DRAWING		RESTRICTED TO -															
		SCALE 3:1		SHEET 1 of 3															
				REV A2															

P	LTR	DESCRIPTION	DATE	DWN	APVD
-	-	SEE SHEET 1	-	-	-

SUGGESTED PCB LAYOUT

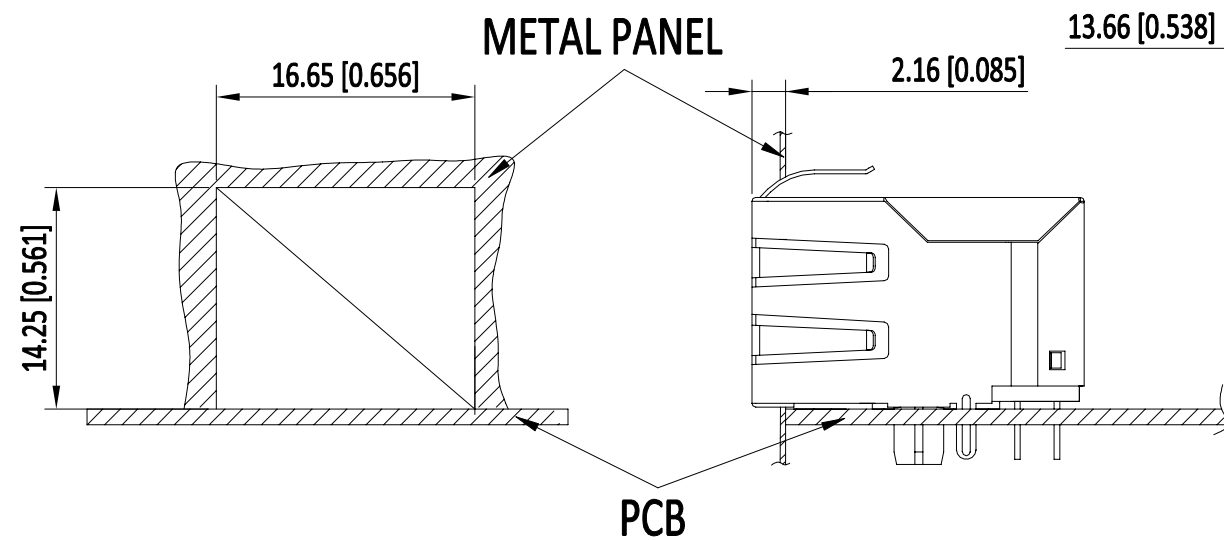
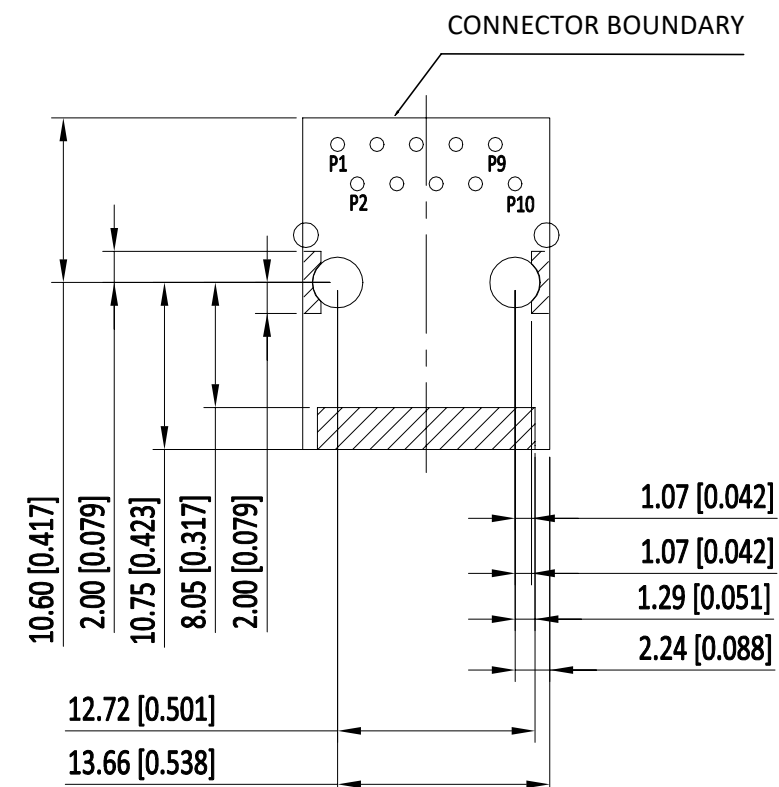
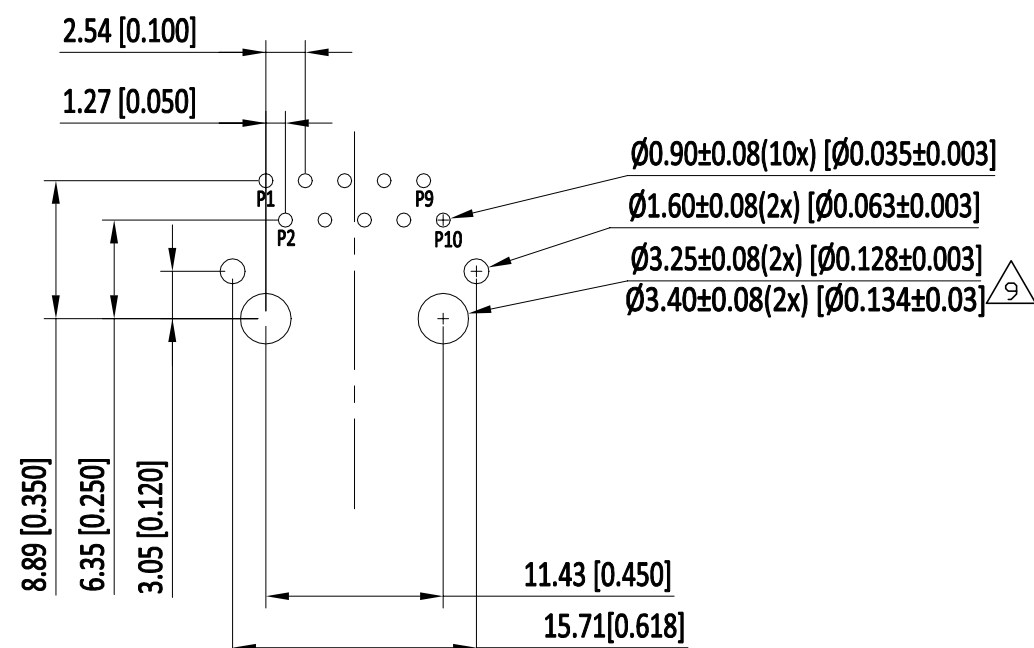

UNIT: mm / inch
 TOLERANCES: $\pm 0.10 / 0.004$
 ONLY FOR THIS VIEW

THIS DRAWING IS A CONTROLLED DOCUMENT.		DWN GANESH C M 27AUG2016	TE Connectivity Ltd.	
		CHK FRANZ MUELLER 27AUG2016		
DIMENSIONS: mm [INCHES]		APVD MARTIN SZELAG 27AUG2016	NAME RJ45 JACK INT.MAG. 1Gb 1x1	
		PRODUCT SPEC 108-94552	RESTRICTED TO	
TOLERANCES UNLESS OTHERWISE SPECIFIED: 0 PLC $\pm -$ 1 PLC $\pm -$ 2 PLC $\pm -$ 3 PLC $\pm -$ 4 PLC $\pm -$ ANGLES $\pm -$		APPLICATION SPEC 114-94447	SIZE A3	CAGE CODE 00779
MATERIAL 1		WEIGHT -	DRAWING NO C=7-2301994-1	
FINISH 1		CUSTOMER DRAWING		SCALE 3:1
		SHEET 2 OF 3		REV A2

P	LTR	DESCRIPTION	DATE	DWN	APVD
-	-	SEE SHEET 1	-	-	-

ELECTRICAL CIRCUIT DIAGRAM

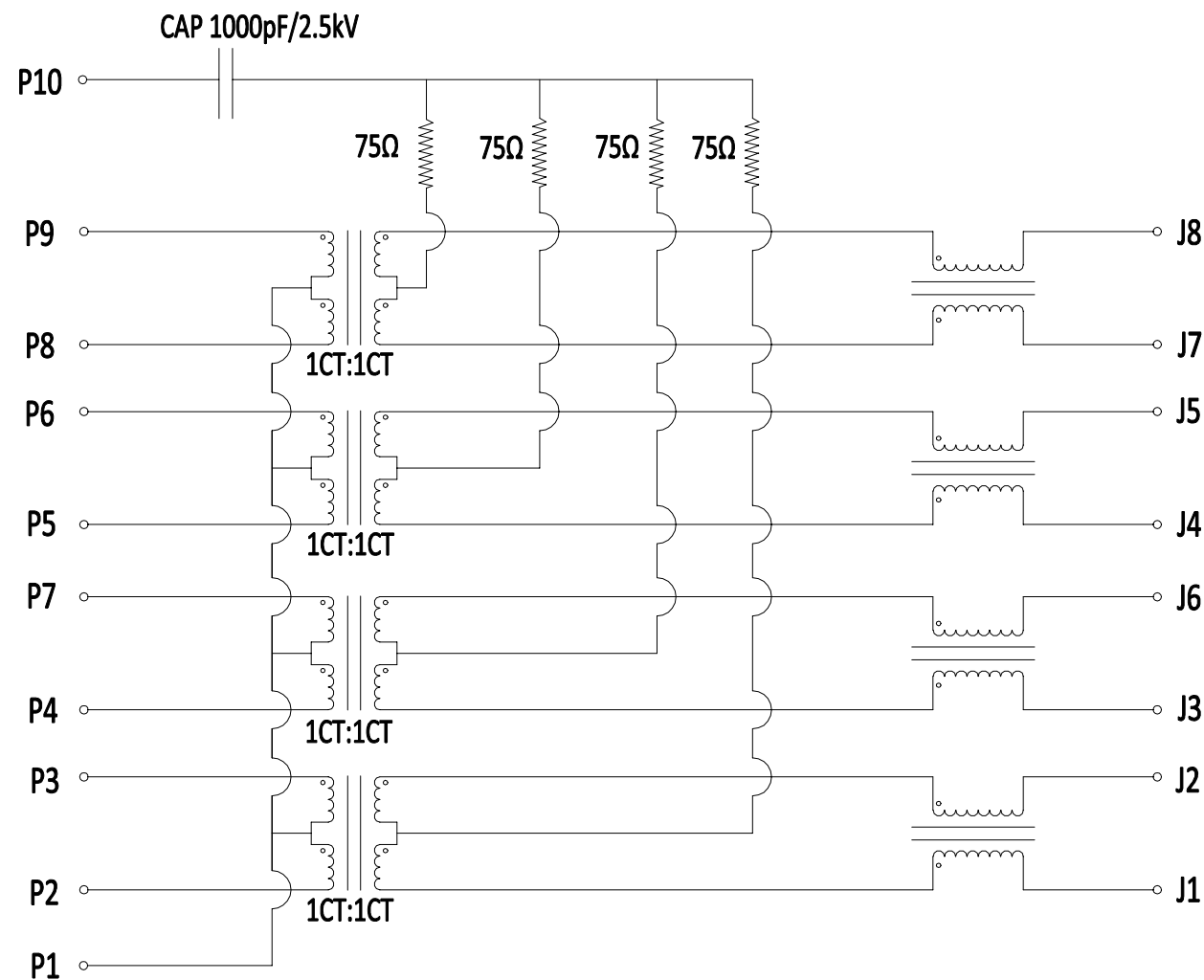

1. TURN RATIO @100kHz: (P2~P3):(J1~J2) = 1:1±2%
 (P4~P7):(J3~J6) = 1:1±2%
 (P5~P6):(J4~J5) = 1:1±2%
 (P8~P9):(J7~J8) = 1:1±2%
2. PRIMARY INDUCTANCE: 350μH MIN. @100kHz,0.1V 8mA DC BIAS
3. DC RESISTANCE: 1.2 OHMS MAX.
4. INSERTION LOSS: 1-100MHz -1.0dB MAX.
 100-125MHz -1.2dB MAX.
5. RETURN LOSS: 1-40MHz -16dB MIN.
 40-100MHz -10dB+20log(f/80MHz) MIN.
6. CROSS TALK: 1-100MHz -30dB MIN.
7. COMMON TO COMMON MODE ATTENUATION: 1-100MHz -30dB MIN.
8. ISOLATION: PHY SIDE TO LINE SIDE: 2250VDC

7-2301994-1
WWYY-xxxx

TE

FCC

CONTROL CODE
DATE CODE
"0213"
YY-YEAR
WW-WEEK

THIS DRAWING IS A CONTROLLED DOCUMENT.		DWN GANESH C M 27AUG2016	TE TE Connectivity Ltd.	
		CHK FRANZ MUELLER 27AUG2016		
DIMENSIONS: mm [INCHES]		APVD MARTIN SZELAG 27AUG2016	NAME RJ45 JACK INT.MAG. 1Gb 1x1	
TOLERANCES UNLESS OTHERWISE SPECIFIED: 0 PLC ± - 1 PLC ± - 2 PLC ± - 3 PLC ± - 4 PLC ± - ANGLES ± -		PRODUCT SPEC 108-94552	RESTRICTED TO	
MATERIAL 1		FINISH 1	APPLICATION SPEC 114-94447	SIZE A3
		WEIGHT -	CAGE CODE 00779	DRAWING NO C=7-2301994-1
CUSTOMER DRAWING			SCALE 3:1	SHEET 3 OF 3
			REV A2	