

REVISIONS			
REV	DESCRIPTION	DATE	APPV

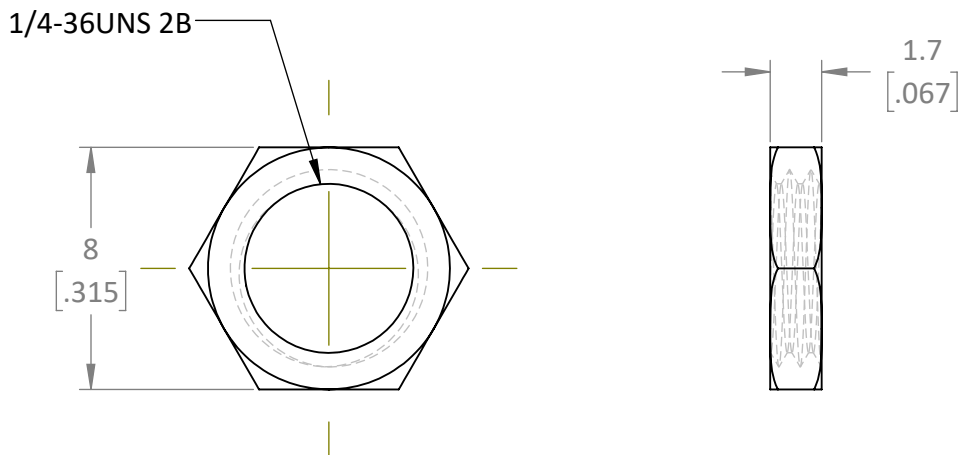

NOTES: (UNLESS OTHERWISE SPECIFIED)

1. ALL DIMENSIONS ARE IN MILLIMETERS [in].
2. DIMENSIONS APPLY AFTER FINISHING.
3. MANUFACTURE TO BE COMPLIANT WITH EU RoHS DIRECTIVE, USE MATERIALS THAT DO NOT CONTAIN REACH SUBSTANCES OF VERY HIGH CONCERN >1000ppm, AND USE DRC CONFLICT-FREE SOURCED MATERIALS.
4. SAFETY BREAK ALL SHARP CORNERS AND EDGES .02 MAXIMUM.

FINISH VARIATIONS	
FINISH	PART NUMBER
NICKEL	NT-SMA-N
GOLD	NT-SMA-G

WARNING: THIS DRAWING CONTAINS PROPRIETARY INFORMATION THAT IS THE SOLE PROPERTY OF LINX TECHNOLOGIES, AND SHALL BE TREATED AS SUCH. NO DISCLOSURE OR REPRODUCTION OF THIS DOCUMENT IS PERMITTED, IN WHOLE OR IN PART, WITHOUT THE EXPRESS WRITTEN PERMISSION OF LINX TECHNOLOGIES OR ITS DESIGNATED AGENTS.



159 ORT LANE
MERLIN, OR 97532

MATERIAL: Brass	INTERPRET DIMENSIONS AND TOLERANCES PER ASME Y14.5.		PROJECTION: 	TITLE: NUT BRAS 1/4-36UNS2B VAR B1.1		
	.X ±2.0	ANGLES: ±1°		SIZE	DWG. NO.	REV
FINISH: -N [NICKEL] -G [GOLD]	.XX ±1.00	SURFACE:	A	C-NT-SMA-X		A
	.XXX ±.500			SCALE: 4:1	DO NOT SCALE DRAWING	
	DRAWN: JHAGER	DT: 8/3/20				
	ENGR: S.HOGAN	DT:				