



CONBNC002

BNC Jack PCB Through-Hole Connector

The CONBNC002 is a BNC right-angle panel-mount jack PCB through-hole connector designed for reflow-solder mounting directly to a printed circuit board. The CONBNC002 combines superior performance, compact size, and a convenient bayonet-style (push-twist) mating interface to provide a reliable, easy-to-use connector. Additionally, all Linx connectors meet RoHS and REACH lead free standards and are tested to meet requirements for corrosion resistance, vibration, mechanical and thermal shock.

FEATURES

- BNC jack (female socket) connection
 - Gold plated brass center contact
 - Bayonet-style (push-twist) connection
- Direct PCB attachment
- Reflow- or hand-solder assembly
- Isolated ground

APPLICATIONS

- Audio/Video
- Broadcasting
- Test Equipment
- Surveillance Systems
- Ethernet
- Industrial, Commercial, Enterprise

ORDERING INFORMATION

Part Number	Description
CONBNC002	BNC jack (female socket) right-angle PCB through-hole connector

Available from Linx Technologies and select distributors and representatives.

PERFORMANCE

Table 1 shows the electrical specifications, insertion loss and VSWR values for the CONBNC002 connector across the operating frequency range.

TABLE 1. ELECTRICAL SPECIFICATIONS

Band	Sub-1 GHz
Frequency Range	0 Hz to 1 GHz
Insertion Loss (dB max.)	0.89
VSWR (max.)	1.9
Impedance	50 Ω

Insertion loss is the loss of signal power (gain) resulting from the insertion of a device in a transmission line (Figure 1). VSWR (Figure 2) describes how efficiently power is transmitted through the connector. A lower VSWR value indicates better performance at a given frequency.

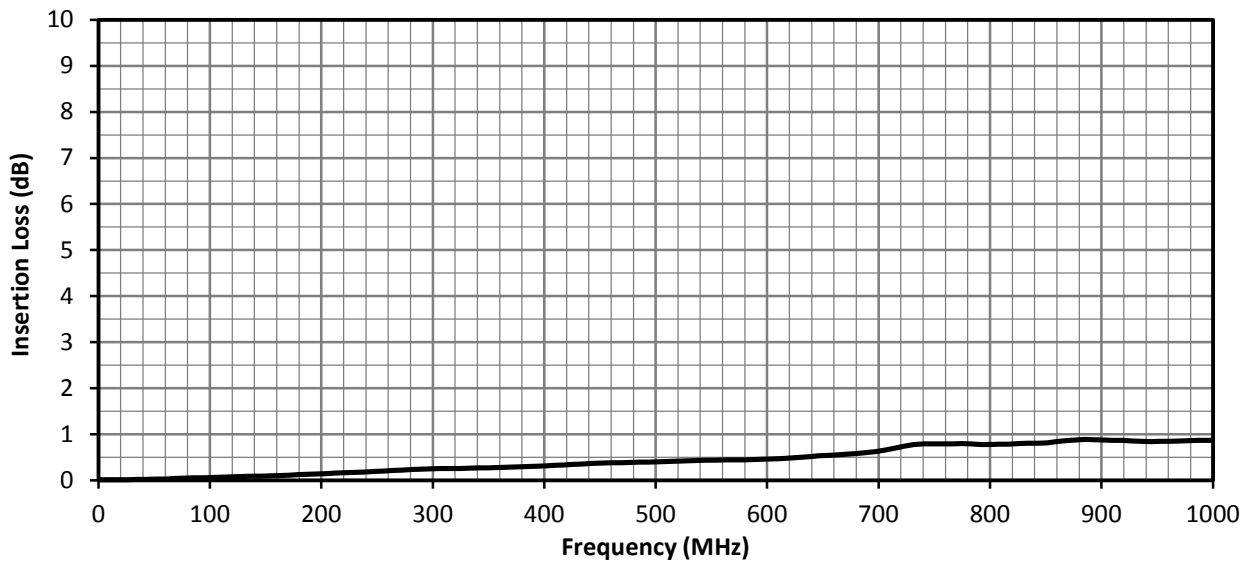

Figure 1. Insertion Loss for CONBNC002 Connector

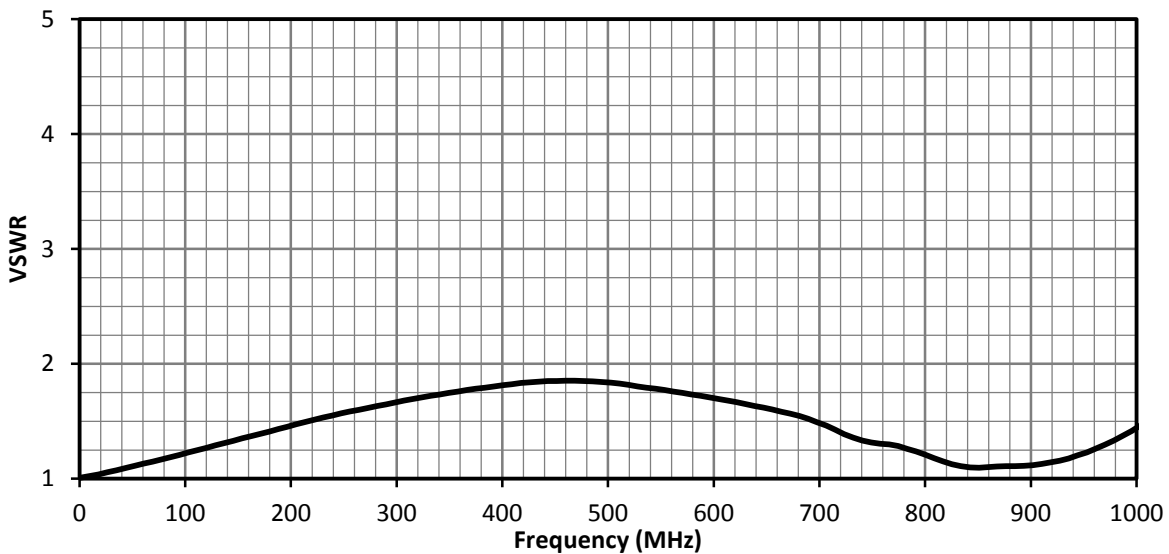

Figure 2. VSWR for the CONBNC002 Connector

TABLE 2. MECHANICAL SPECIFICATIONS

Parameter	Value
Mounting Type	PCB Through-Hole
Fastening Type	Bayonet-style Coupling (Push/Twist)
Interface in Accordance with	MIL-STD-348B
Weight	11.3 g (0.40 oz)

TABLE 3. ENVIRONMENTAL SPECIFICATIONS

	MIL-STD, Method, Test Condition
Corrosion (Salt spray)	MIL-STD-202 Method 101 test condition B
Thermal Shock	MIL-STD-202 Method 107 test condition C
Vibration	MIL-STD-202 Method 204 test condition B
Mechanical Shock	MIL-STD-202 Method 213 test condition B
Moisture Resistance	MIL-STD-202 Method 106 test condition D
Temperature Range	-60 °C to +165 °C
Environmental Compliance	RoHS, REACH

PRODUCT DIMENSIONS

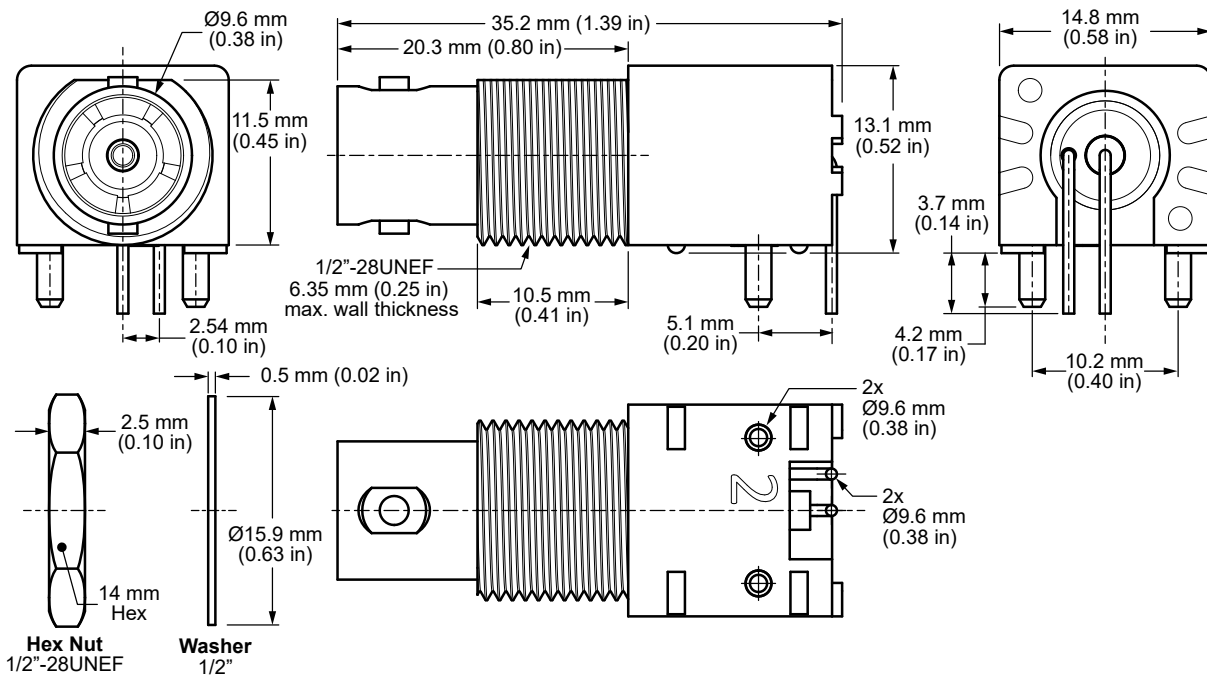

Figure 3. Product Dimensions for the CONBNC002 Connector

Parameter	Value	
Connector Part	Material	Finish
Body	Zinc	Nickel
Center Contact	Phosphor Bronze	Gold
Insulator	Polypropylene (PP)	-
Washer	Steel	Nickel
Nut	Brass	Nickel

RECOMMENDED PCB FOOTPRINT AND MOUNTING DIMENSIONS

Figure 4 shows the recommended PCB footprint for the CONBNC002 connector. Figure 5 shows the recommended enclosure mounting dimensions. The maximum enclosure wall thickness should be no greater than 6.35 mm (0.25 in).

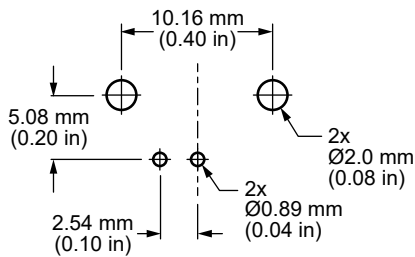

Figure 4. Recommended PCB Footprint

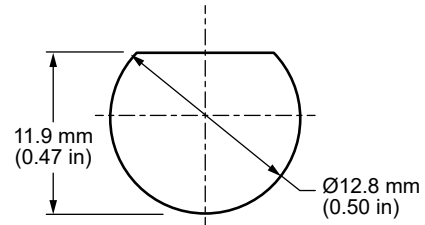

Figure 5. Recommended Mounting Dimensions

REFLOW SOLDER PROFILE

Figure 6 shows the time and temperature data for reflow soldering the connector to a PCB.

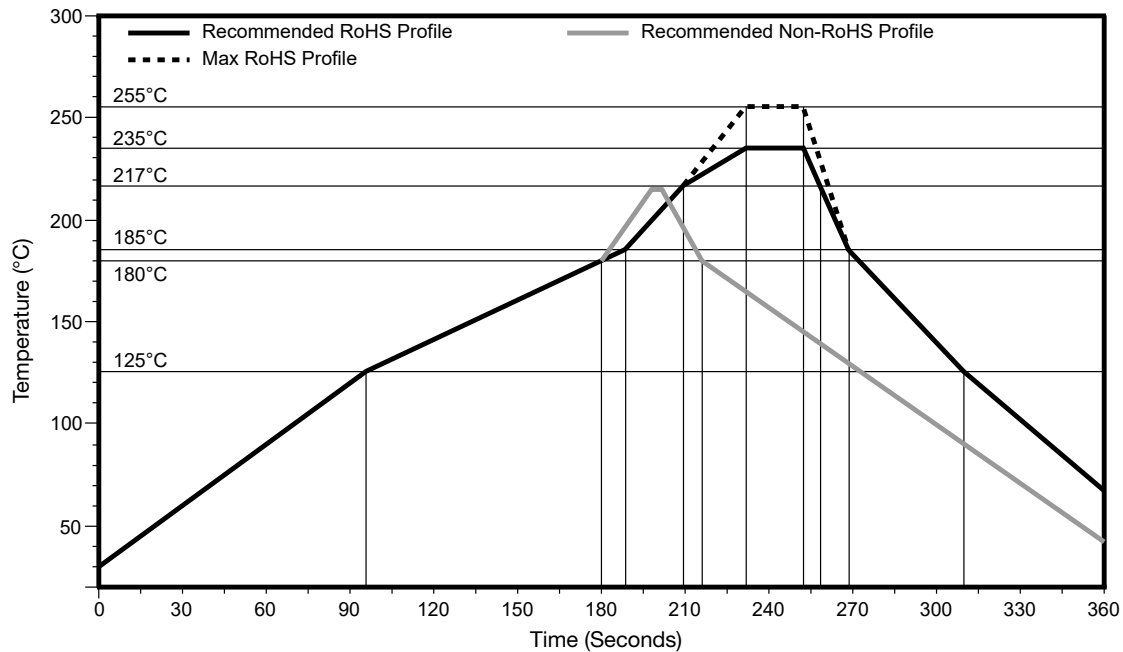

Figure 6. Recommended Reflow Solder Profile

PACKAGING INFORMATION

The CONBNC002 connector is packaged in a plastic bag of 100 pcs, 1000 Pcs per carton. Carton size is 325 mm x 260 mm x 260 mm (12.80 in x 10.24 in x 10.24 in) Distribution channels may offer alternative packaging options.

CONNECTOR & ADAPTER DEFINITIONS AND USEFUL FORMULAS

VSWR - Voltage Standing Wave Ratio. VSWR is a unitless ratio that describes how efficiently power is transmitted through the connector. A lower VSWR value indicates better performance at a given frequency. VSWR is easily derived from Return Loss.

$$VSWR = \frac{10^{\left[\frac{\text{Return Loss}}{20}\right]} + 1}{10^{\left[\frac{\text{Return Loss}}{20}\right]} - 1}$$

Insertion Loss - The loss of signal power (gain) resulting from the insertion of a device in a transmission line. Insertion loss can be derived from the power transmitted to the load before the insertion of the component P_T and the power transmitted to the load after the insertion of the component P_R .

$$\text{Insertion Loss (dB)} = 10 \log_{10} \frac{P_T}{P_R}$$

TE TECHNICAL SUPPORT CENTER

USA:	+1 (800) 522-6752
Canada:	+1 (905) 475-6222
Mexico:	+52 (0) 55-1106-0800
Latin/S. America:	+54 (0) 11-4733-2200
Germany:	+49 (0) 6251-133-1999
UK:	+44 (0) 800-267666
France:	+33 (0) 1-3420-8686
Netherlands:	+31 (0) 73-6246-999
China:	+86 (0) 400-820-6015

te.com

TE Connectivity, TE, TE connectivity (logo), Linx and Linx Technologies are trademarks owned or licensed by the TE Connectivity Ltd. family of companies. All other logos, products and/or company names referred to herein might be trademarks of their respective owners.

The information given herein, including drawings, illustrations and schematics which are intended for illustration purposes only, is believed to be reliable. However, TE Connectivity makes no warranties as to its accuracy or completeness and disclaims any liability in connection with its use. TE Connectivity's obligations shall only be as set forth in TE Connectivity's Standard Terms and Conditions of Sale for this product and in no case will TE Connectivity be liable for any incidental, indirect or consequential damages arising out of the sale, resale, use or misuse of the product. Users of TE Connectivity products should make their own evaluation to determine the suitability of each such product for the specific application.

TE Connectivity warrants to the original end user customer of its products that its products are free from defects in material and workmanship. Subject to conditions and limitations TE Connectivity will, at its option, either repair or replace any part of its products that prove defective because of improper workmanship or materials. This limited warranty is in force for the useful lifetime of the original end product into which the TE Connectivity product is installed. Useful lifetime of the original end product may vary but is not warranted to exceed one (1) year from the original date of the end product purchase.

©2022 TE Connectivity. All Rights Reserved.

10/22 Original