

Description	Material	Finish
Body	Brass	Gold
Socket	BE CU	Gold
Insulation	PTFE	N/A
Washer	Brass	Gold
Nut	Brass	Gold

REVISIONS			
REV	DESCRIPTION	DATE	APPV
B	Added new title block	11-JUL-12	SAH

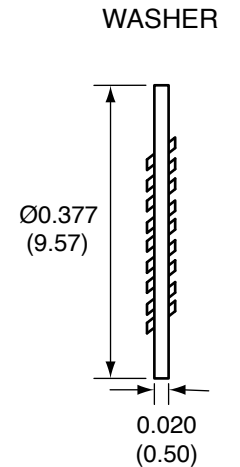

**RECOMMENDED MOUNTING HOLE**

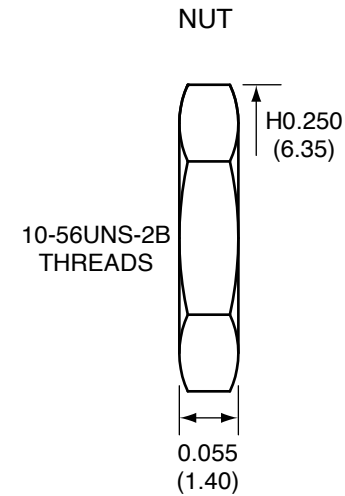
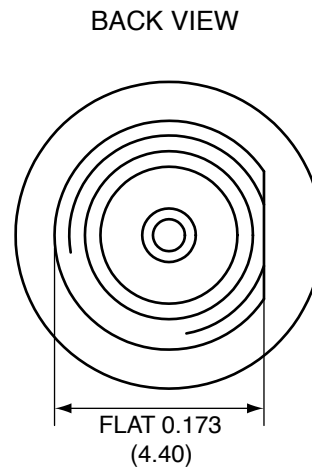
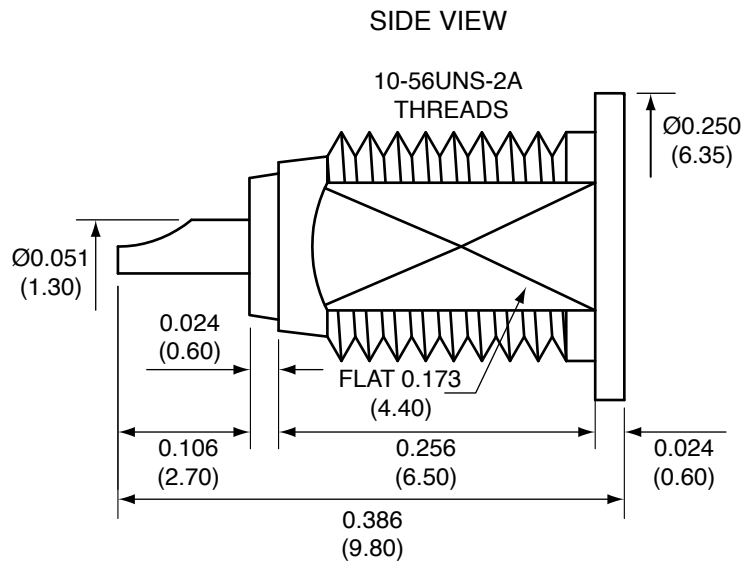
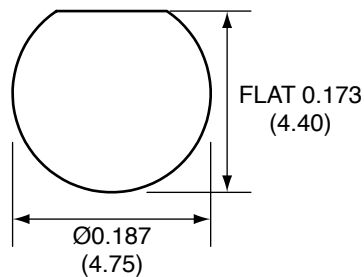

**NOTES: (UNLESS OTHERWISE SPECIFIED)**

1. ALL DIMENSIONS ARE IN INCHES [mm].
2. DIMENSIONS APPLY AFTER FINISHING.
3. MANUFACTURE TO BE COMPLIANT WITH EU RoHS DIRECTIVE.
4. SAFETY BREAK ALL SHARP CORNERS AND EDGES .02 MAXIMUM.

**WARNING:** THIS DRAWING CONTAINS PROPRIETARY INFORMATION THAT IS THE SOLE PROPERTY OF LINX TECHNOLOGIES, AND SHALL BE TREATED AS SUCH. NO DISCLOSURE OR REPRODUCTION OF THIS DOCUMENT IS PERMITTED, IN WHOLE OR IN PART, WITHOUT THE EXPRESS WRITTEN PERMISSION OF LINX TECHNOLOGIES OR ITS DESIGNATED AGENTS.

MATERIAL:	TOLERANCES: .020 [0.50]-.200 [5.00]= ±.008 [0.20] .200 [5.00]-1.200 [30.00]= ±.016 [0.40] 1.20 [30.0]-4.75 [120.0]= ±.024 [0.60] 4.75 [120.0]-12.40 [315.0]= ±.040 [1.0]	PROJECTION: 
FINISH:	DRAWN: B.MURPHY DT: 11-JUL-12	ANGLES: ±1°
	ENGR: S.HOGAN DT: 11-JUL-12	



TITLE:  
**MCX FEMALE BULKHEAD  
FRONT MOUNT WITH SOLDER POT**

SIZE <b>A</b>	DWG. NO. <b>CONMCX004</b>	REV <b>B</b>
SCALE: 2:1	DO NOT SCALE DRAWING	SHEET 1 OF 1