

Connector: RP-SMA Jack (Male Pin)			
Termination: Cable End Crimp, RG-174 or Equivalent			
Part Number		CONREVSMA005	CONREVSMA005-G
Connector Part	Material	Finish	Finish
Bodies	Body: Brass	Nickel	Gold
	Shield Sleeve: Brass	Nickel	Gold
	Retaining Nut: Brass	Nickel	Gold
	Crimp Ring: Brass	Nickel	Gold
	Washer: Brass	Nickel	Gold
	Nut: Brass	Nickel	Gold
Center Contact	Pin: Brass	Gold	Gold
Pin Insulator	PTFE	-	-
Spacer	PTFE	-	-
Heat Shrink	Polyolefin	-	-

REVISIONS			
REV	DESCRIPTION	DATE	APPV
A	INITIAL RELEASE OF LINX INTERNAL DRAWING	01/MAR/19	CLL

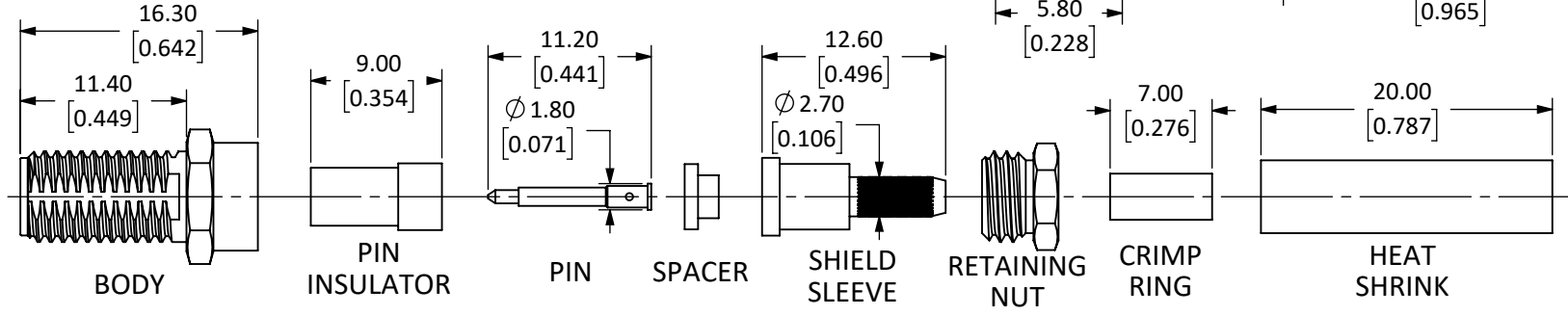
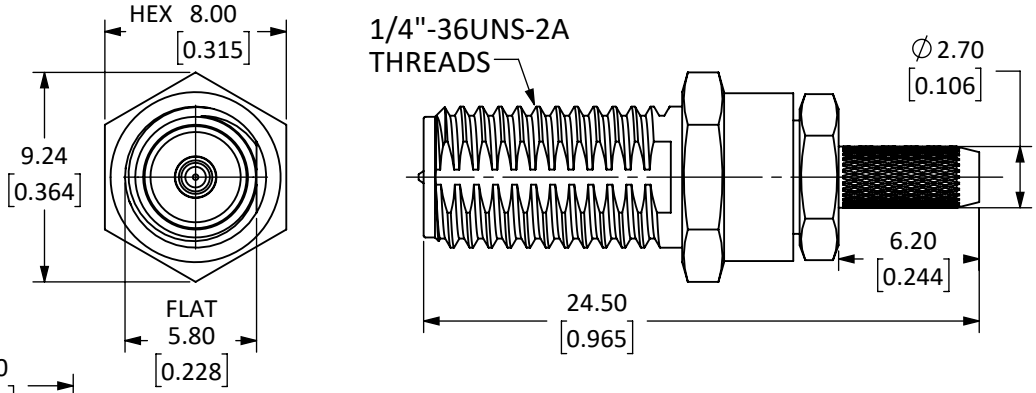

EXPLODED VIEW
SCALE 2 : 1

- NOTES: (UNLESS OTHERWISE SPECIFIED)
1. ALL DIMENSIONS ARE IN mm [INCHES].
 2. DIMENSIONS APPLY AFTER FINISHING.
 3. MANUFACTURE TO BE COMPLIANT WITH EU RoHS DIRECTIVE, USE MATERIALS THAT DO NOT CONTAIN REACH SUBSTANCES OF VERY HIGH CONCERN >1000ppm, AND USE DRC CONFLICT-FREE SOURCED MATERIALS.
 4. SAFETY BREAK ALL SHARP CORNERS AND EDGES 0.5 MAXIMUM.
 5. SEE TABLE I FOR ELECTRICAL SPECIFICATIONS. (SHEET 2)
 6. SEE TABLE II FOR ENVIRONMENTAL SPECIFICATIONS. (SHEET 2)
 7. SEE TABLE III FOR MECHANICAL SPECIFICATIONS. (SHEET 2)
 8. SEE PARTLIST. "*" INDICATES FINISH TYPE.

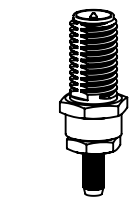

SCALE 1 : 1

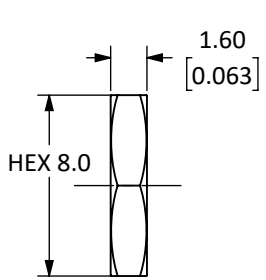

NUT

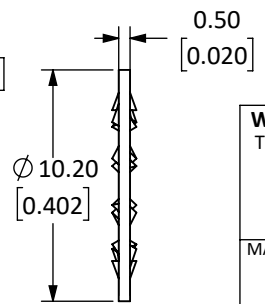

WASHER

WARNING: THIS DRAWING CONTAINS PROPRIETARY INFORMATION THAT IS THE SOLE PROPERTY OF LINX TECHNOLOGIES, AND SHALL BE TREATED AS SUCH. NO DISCLOSURE OR REPRODUCTION OF THIS DOCUMENT IS PERMITTED, IN WHOLE OR IN PART, WITHOUT THE EXPRESS WRITTEN PERMISSION OF LINX TECHNOLOGIES OR ITS DESIGNATED AGENTS.

MATERIAL:	TOLERANCES: 0.50 [0.020]-5.00 [0.200]= ±0.20 [0.008] 5.00 [0.200]-30.00 [1.200]= ±0.40 [0.016] 30.0 [1.200]-120.0 [4.75]= ±0.60 [0.24] 120.0 [4.75]-315.0 [12.40]= ±1.0 [0.040]	PROJECTION:
FINISH:	DRAWN: M. SCHULTE ENGR: D. VARATHARAJAN	DT: 21/JAN/19 DT: 08/MAR/19



TITLE:
**RP-SMA FEMALE BULKHEAD MOUNT
CABLE END CRIMP FOR RG-174 CABLE**

SIZE	DWG. NO.	REV
A	CONREVSMA005-*	A
SCALE: 3:1		SHEET 1 OF 2

DO NOT SCALE DRAWING

5 TABLE I

Electrical Data	Detail
Impedance	50 Ω
Frequency Range	0 to 18 GHz
Insulation Resistance	5 000 M Ω min.
Voltage Rating	1 000 V RMS
Contact Resistance	Center: ≤ 3.0 m Ω Outer: ≤ 2.5 m Ω
Working Voltage	RG-174, or Equivalent \rightarrow 335 V RMS max.
Dielectric Withstanding Voltage	RG-174, or Equivalent \rightarrow 750 V RMS max.

6 TABLE II

Environmental Data	Detail
Corrosion (Salt spray)	ASTMB-117
Thermal Shock	MIL-STD-202 Method 107 test condition B
Vibration	MIL-STD-202 Method 204 test condition D
Mechanical Shock	MIL-STD-202 Method 213 test condition I
Temperature Range	-55 $^{\circ}$ C to +155 $^{\circ}$ C
Environmental Compliance	RoHS

7 TABLE III

Mechanical Data	Detail
Mounting Type	Bulkhead Rear Mount
Fastening Type	1/4"-36 Threaded Coupling
Recommended Torque	0.57 N·m (5.0 in·lbs)
Coupling Nut Retention	60 lbs. min.
Connector Durability	500 cycles min.
Weight	4.5 g (0.16 oz)

ASSEMBLY INSTRUCTIONS

- Strip cable to recommended dimensions.
- Slip heat shrink and crimp ring onto stripped cable.
- Insert the stripped cable through the retaining nut, shield sleeve and spacer.
- Solder the pin to the center-conductor.
- Insert the pin into the pin insulator, then screw the main body onto the retaining nut.
- Wrap the braid around the tail of the body and crimp the ring with a 0.128" hex crimp tool (or one labeled for use with RG-174 cable)
- Use heat shrink to cover crimp.
- Use the nut and washer to secure the connector to a case.

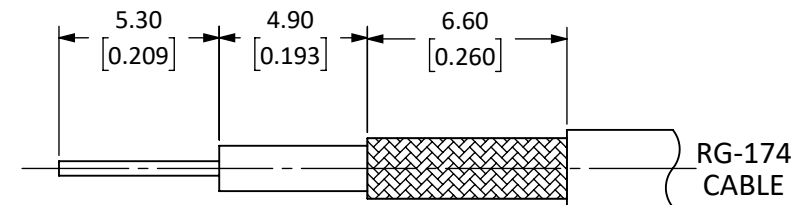

RECOMMENDED CABLE STRIPPING DIMENSIONS
CAN ALSO BE USED WITH:
RG-188A & RG-316

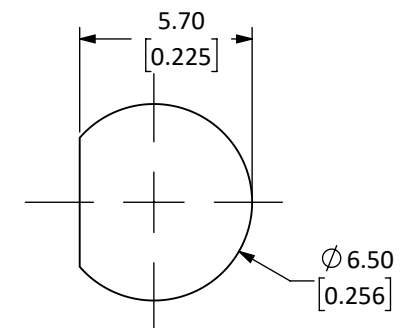

RECOMMENDED MOUNTING HOLE

SIZE	DWG. NO.	REV
A	CONREVSMA005-*	A
SCALE: 4:1	DO NOT SCALE DRAWING	SHEET 2 OF 2