

BILL OF MATERIALS		
ITEM	DESCRIPTION	QTY.
1	BODY, CONNECTOR, SMA, BRASS, RG178	1
2	PIN, BECU, KNUR, SOLDER, RG-174, GOLD	1
3	SPACER, SUPPORT, PTFE, RG-174	1
4	COLLAR, SHIELD, SOLDER, BRASS, GOLD	1
5	HEAT SHRINK, PE, ID Ø3mm	20mm

REVISIONS			
REV	DESCRIPTION	DATE	APPV
B	UPDATED FOOTPRINT AND DIMENSIONS. ADDED NEW TITLE BLOCK	BMURPHY 7/2/12	SAH
C	UPDATED DRAWING AND MODELS. ADDED SMS MODEL AND ASSEMBLY. REVISED DRAWING TO SHOW UPDATED PARTS.	JHAGER 10/20/2020	CL 10/28/20

**ASSEMBLY INSTRUCTIONS:**

1. STRIP CABLE TO RECOMMENDED DIMENSIONS.
2. SLIP HEAT SHRINK ONTO STRIPPED CABLE.
3. PLACE SPACER [FN3] ONTO CENTER CONDUCTOR.
4. SOLDER PIN [FN2] ONTO CENTER CONDUCTOR.
5. INSERT PIN AND SPACER THROUGH GROUNDING COLLAR [FN4] AND OVER BRAID.
6. INSERT ASSEMBLY INTO [FN1] BODY UNTIL THE TOP OF THE SOCKET IS FLUSH WITH INSULATION.
7. SOLDER OR CRIMP KNURELED END TO CROUNDING COLLAR.
8. SLIDE HEAT SHRINK OVER ASSEMBLY AND SHRINK IN PLACE.

**NOTES: (UNLESS OTHERWISE SPECIFIED)**

1. ALL DIMENSIONS ARE IN MILLIMETERS [IN].
2. DIMENSIONS APPLY AFTER FINISHING.
3. MANUFACTURE TO BE COMPLIANT WITH EU RoHS DIRECTIVE, USE MATERIALS THAT DO NOT CONTAIN REACH SUBSTANCES OF VERY HIGH CONCERN >1000ppm, AND USE DRC CONFLICT-FREE SOURCED MATERIALS.
4. BREAK AND DEBURR SHARP EDGES .02mm
5. ELECTRICAL:
  1. IMPEDANCE: 50Ω
  2. INSULATION: 5000MΩ
  3. VOLTAGE: WORKING 335V RMS [750V RMS MAX]
  4. CONTACT RESISTANCE: PIN: <3mΩ OUTER: <2.5mΩ
  5. VSWR: 1.12 + .02f
6. MECHANICAL:
  1. MOUNTING: FREE HANGING [IN-LINE]
  2. INTERFACE: SMA IAW MIL-STD-348
  3. DURABILITY: 500 CYCLES
  4. TORQUE MAX: .57 N/m [5.0 IN/LBS] MAX
  5. WRENCH: 6.35mm [1/4 IN]
7. ENVIRONMENTAL: IAW MIL-STD-202
  1. SALT FOG: ASTM B-117
  2. THERMAL: 107b
  3. VIBRATION: 204d
  4. SHOCK: 213i
  5. TEMP: -55°C- +155°C MAX

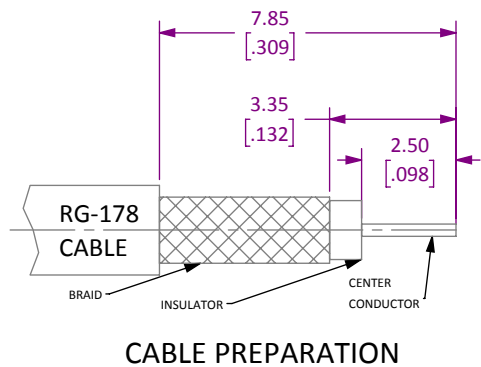
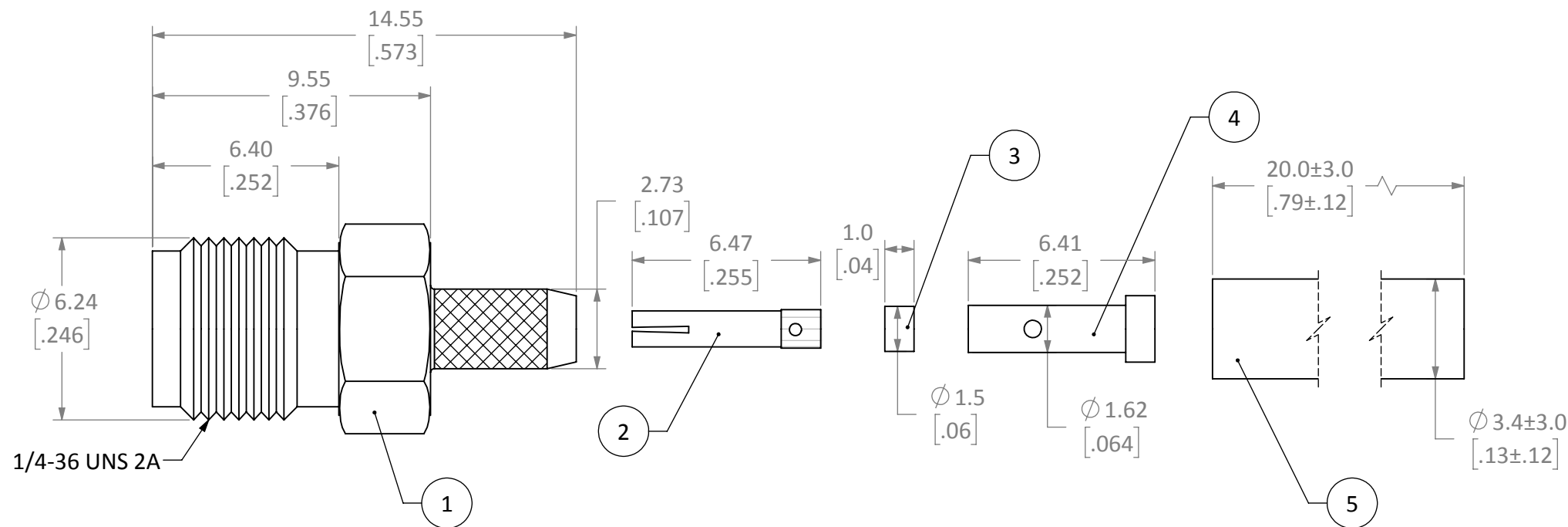

**WARNING:** THIS DRAWING CONTAINS PROPRIETARY INFORMATION THAT IS THE SOLE PROPERTY OF LINX TECHNOLOGIES, AND SHALL BE TREATED AS SUCH. NO DISCLOSURE OR REPRODUCTION OF THIS DOCUMENT IS PERMITTED, IN WHOLE OR IN PART, WITHOUT THE EXPRESS WRITTEN PERMISSION OF LINX TECHNOLOGIES OR ITS DESIGNATED AGENTS.

MATERIAL: BRASS BE CU	INTERPRET DIMENSIONS AND TOLERANCES PER ASME Y14.5. .X ±1 .XX ±.04 .XXX ±.005	ANGLES: ±1° SURFACE: √	PROJECTION: 
FINISH: NiC GOLD	DRAWN: BMURPHY ENGR:	DT: 07/02/12 DT: 07/02/12	



TITLE:  
SMA Female Cable End Crimp - RG-178 Cable - with Support #B-SMA0473 & Shrink Tube #RU-0033-20 - RoHS

SIZE <b>B</b>	DWG. NO. CONSMSA011-R178	REV <b>C</b>
------------------	-----------------------------	-----------------

SCALE: 5:1	DO NOT SCALE DRAWING	SHEET 1 OF 1
------------	----------------------	--------------