

Connector: SMA Jack (Female Socket)			
Termination: Cable End Crimp			
Part Number	CONSMA014-R178		CONSMA014-R178-G
Connector Part	Material	Finish	Finish
Bodies	Body: Brass	Nickel	Gold
	Nut: Brass	Nickel	Gold
	Washer: Brass	Nickel	Gold
Center Contact	Socket: Be Cu	Gold	Gold
Insulator	PTFE	-	-
Gasket	Silicone Rubber	-	-

REVISIONS			
REV	DESCRIPTION	DATE	APPV
A	INITIAL RELEASE OF LINX INTERNAL DRAWING	01/MAR/19	CLL

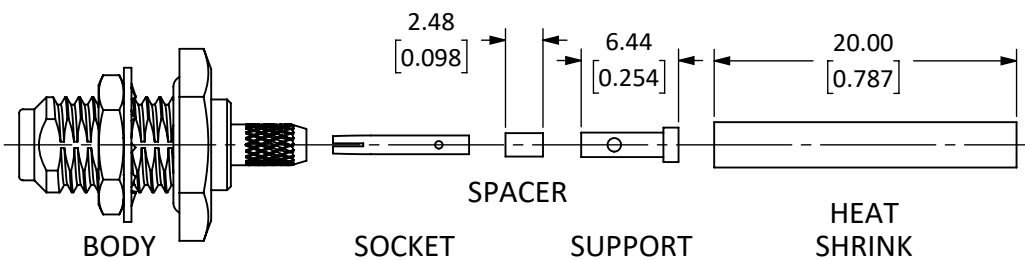
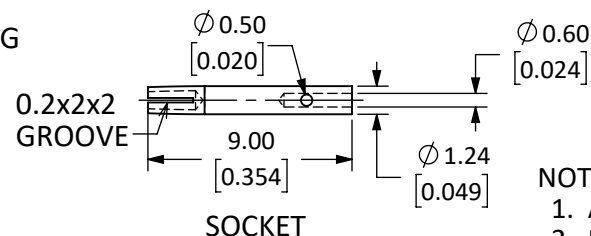
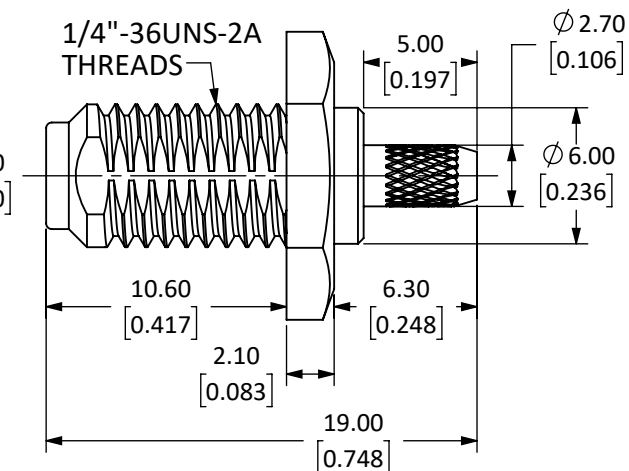
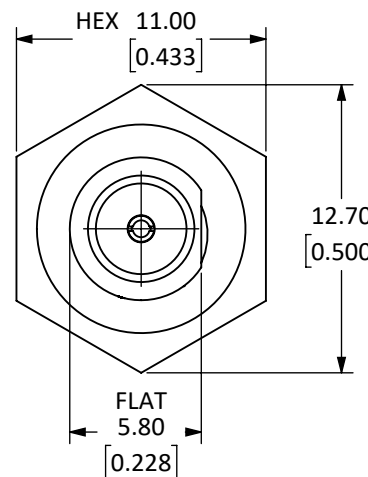
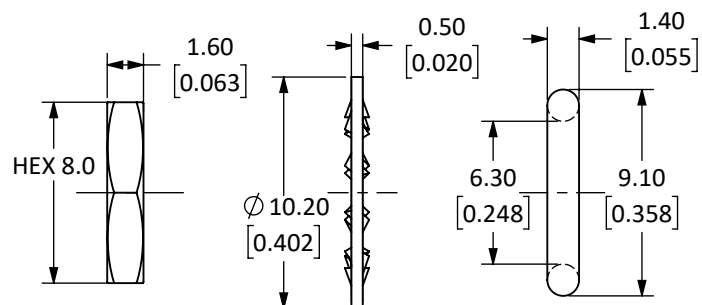

EXPLODED VIEW
SCALE 2 : 1

NOTES: (UNLESS OTHERWISE SPECIFIED)

1. ALL DIMENSIONS ARE IN mm [INCHES].
2. DIMENSIONS APPLY AFTER FINISHING.
3. MANUFACTURE TO BE COMPLIANT WITH EU RoHS DIRECTIVE, USE MATERIALS THAT DO NOT CONTAIN REACH SUBSTANCES OF VERY HIGH CONCERN >1000ppm, AND USE DRC CONFLICT-FREE SOURCED MATERIALS.
4. SAFETY BREAK ALL SHARP CORNERS AND EDGES 0.5 MAXIMUM.
5. SEE TABLE I FOR ELECTRICAL SPECIFICATIONS. (SHEET 2)
6. SEE TABLE II FOR ENVIRONMENTAL SPECIFICATIONS. (SHEET 2)
7. SEE TABLE III FOR MECHANICAL SPECIFICATIONS. (SHEET 2)
8. SEE PARTSLIST. "*" INDICATES FINISH TYPE.

WARNING: THIS DRAWING CONTAINS PROPRIETARY INFORMATION THAT IS THE SOLE PROPERTY OF LINX TECHNOLOGIES, AND SHALL BE TREATED AS SUCH. NO DISCLOSURE OR REPRODUCTION OF THIS DOCUMENT IS PERMITTED, IN WHOLE OR IN PART, WITHOUT THE EXPRESS WRITTEN PERMISSION OF LINX TECHNOLOGIES OR ITS DESIGNATED AGENTS.

MATERIAL:	TOLERANCES: 0.50 [0.020]-5.00 [0.200]= ±0.20 [0.008] 5.00 [0.200]-30.00 [1.200]= ±0.40 [0.016] 30.0 [1.20]-120.0 [4.75]= ±0.60 [0.24] 120.0 [4.75]-315.0 [12.40]= ±1.0 [0.040]	PROJECTION:
FINISH:	DRAWN: M. SCHULTE ENGR: D. VARATHARAJAN	DT: 21/JAN/19 DT: 08/MAR/19



TITLE:
SMA FEMALE BULKHEAD MOUNT CABLE
END CRIMP WITH O-RING FOR RG-178 CABLE

SIZE	DWG. NO.	REV
A	CONSMA014-R178-*	A
SCALE: 3:1	DO NOT SCALE DRAWING	SHEET 1 OF 2

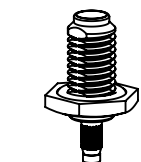

SCALE 1 : 1

5 TABLE I

Electrical Data	Detail
Impedance	50 Ω
Frequency Range	0 to 6 GHz
Insulation Resistance	5 000 M. Ω min.
Voltage Rating	1 000 V RMS
Contact Resistance	Center: ≤ 3.0 m. Ω Outer: ≤ 2.5 m. Ω
VSWR: f (GHz)	RG-178/U, or Equivalent $1.20+0.025f$
Working Voltage	RG-178, or Equivalent $\rightarrow 250$ volts rms max.
Dielectric withstanding Voltage	RG-178, or Equivalent $\rightarrow 500$ volts rms max.
Insertion Loss	0.04 dB max. x \sqrt{f} GHz (straight)

6 TABLE II

Environmental Data	Detail
Corrosion (Salt spray)	ASTM B-117
Thermal Shock	MIL-STD-202 Method 107 test condition B
Vibration	MIL-STD-202 Method 204 test condition D
Mechanical Shock	MIL-STD-202 Method 213 test condition I
Temperature Range	-55 °C to +155 °C
Environmental Compliance	RoHS

7 TABLE III

Mechanical Data	Detail
Mounting Type	Bulkhead Rear-mount, With O-ring
Fastening Type	1/4"-36 Threaded Coupling
Recommended Torque	0.57 N·m (5.0 in·lbs)
Coupling Nut Retention	60 lbs. min.
Connector Durability	500 cycles min.
Weight	3.6 g (0.13 oz)

ASSEMBLY INSTRUCTIONS

1. Strip the cable.
2. Slide the coax into the support until the outside insulation bottoms out against the inside shoulder of the support.
3. Solder the support onto the braid.
4. Place the spacer onto the center-conductor.
5. Solder or crimp the socket onto the center conductor.
6. Insert the socket, center-conductor, spacer and support into the body until the top of the socket is even with the white insulation in the body.
7. Crimp the tail of the body onto the support with a 0.093" hex crimp tool.

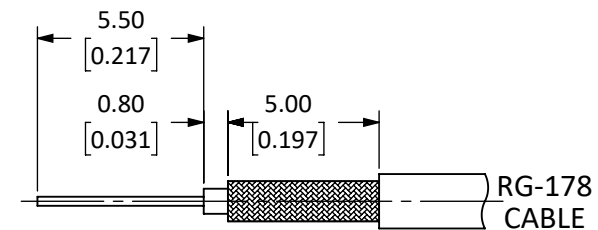

RECOMMENDED CABLE STRIPPING DIMENSIONS
CAN ALSO BE USED WITH:
RG-196

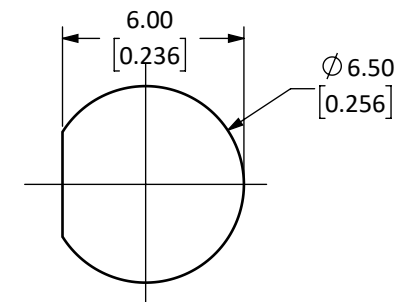

RECOMMENDED MOUNTING HOLE

SIZE	DWG. NO.	REV
A	CON SMA014-R178-*	A
SCALE: 4:1	DO NOT SCALE DRAWING	SHEET 2 OF 2