

ITEM	DESCRIPTION	MATERIAL	FINISH
A	U.FL PLUG	BRASS	GOLD
B	SEALED RP-SMA FEM. BULKHEAD MOUNT CONNECTOR	BRASS	GOLD
C	CABLE	1.13mm COAXIAL	GRAY
D	NUT	BRASS	GOLD
E	WASHER	BRASS	GOLD
F	O-RING	Si RUBBER	BLACK
G	HEAT SHRINK TUBING	POLYOLEFIN	BLACK

REVISIONS			
REV	DESCRIPTION	DATE	APPV
A	INITIAL RELEASE OF LINX INTERNAL DRAWING	18-AUG-17	CLL
B	UPDATED NOTES TO ADD TORQUE SPECIFICATIONS AND PACKAGING INSTRUCTIONS; ADDED MOUNTING HOLE; ADDED "-B" PART NUMBERS; UPDATED DIMENSIONS	27-OCT-17	CLL

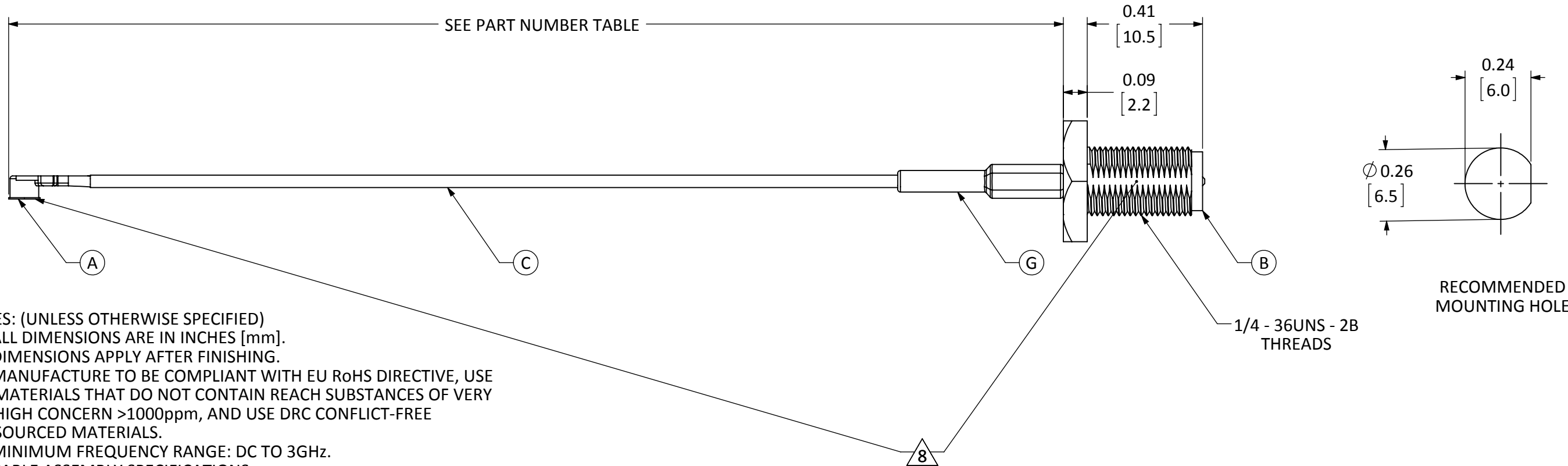
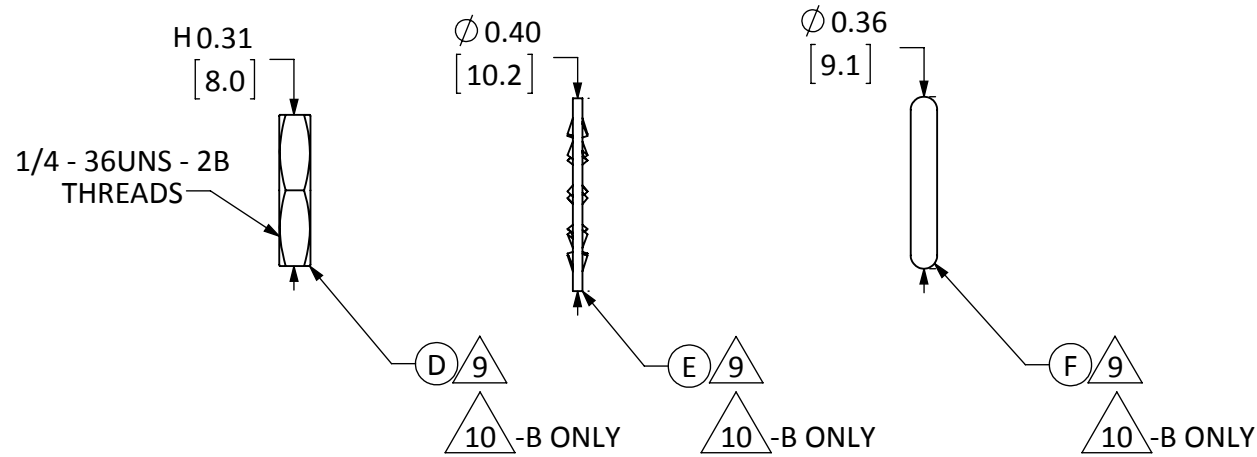

NOTES: (UNLESS OTHERWISE SPECIFIED)

- ALL DIMENSIONS ARE IN INCHES [mm].
- DIMENSIONS APPLY AFTER FINISHING.
- MANUFACTURE TO BE COMPLIANT WITH EU RoHS DIRECTIVE, USE MATERIALS THAT DO NOT CONTAIN REACH SUBSTANCES OF VERY HIGH CONCERN >1000ppm, AND USE DRC CONFLICT-FREE SOURCED MATERIALS.
- MINIMUM FREQUENCY RANGE: DC TO 3GHz.
- CABLE ASSEMBLY SPECIFICATIONS;
 - CHARACTERISITIC IMPEDANCE: $50\Omega \pm 3\Omega$
 - INSERTION LOSS: 100mm - 0.34vf IN GHz TYP.
200mm - 0.56vf IN GHz TYP.
300mm - 0.73vf IN GHz TYP.
- CONNECTORS TO BE APPLIED IN ACCORDANCE WITH CONNECTOR SUPPLIER RECOMMENDED PROCEDURE.
- TORQUE SPECIFICATIONS;
 - BULKHEAD MOUNTING NUT TORQUE: 7 TO 10 in-lbs.
 - RECOMMENDED MATING TORQUE: 7 TO 10 in-lbs.

- 8 CONNECTORS TO BE ORIENTED WITH U.FL CONNECTOR MATING FACE 90° CLOCKWISE FROM BULKHEAD CONNECTOR THREAD FLAT FACE, AS SHOWN.
- 9 INSTALL O-RING (ITEM F), WASHER (ITEM E) AND NUT (ITEM D) ONTO CONNECTOR (ITEM B).
- 10 -B PART NUMBERS ONLY: SHIP O-RINGS (ITEM F), WASHERS (ITEM E) AND NUTS (ITEM D) IN SEPARATE BAGS OF 100 PIECES EACH.

PART NUMBER	CABLE LENGTH
CSI-RGFI-100-UFFR	100mm ± 1.5mm
CSI-RGFI-200-UFFR	200mm ± 3.0mm
CSI-RGFI-300-UFFR	300mm ± 4.5mm
CSI-RGFI-100-UFFR-B	100mm ± 1.5mm
CSI-RGFI-200-UFFR-B	200mm ± 3.0mm
CSI-RGFI-300-UFFR-B	300mm ± 4.5mm

WARNING: THIS DRAWING CONTAINS PROPRIETARY INFORMATION THAT IS THE SOLE PROPERTY OF LINX TECHNOLOGIES, AND SHALL BE TREATED AS SUCH. NO DISCLOSURE OR REPRODUCTION OF THIS DOCUMENT IS PERMITTED, IN WHOLE OR IN PART, WITHOUT THE EXPRESS WRITTEN PERMISSION OF LINX TECHNOLOGIES OR ITS DESIGNATED AGENTS.



TITLE: **CABLE ASSEMBLY, U.FL TO FEM. BLKHD RP-SMA, 1.13mm CBL**

MATERIAL:	INTERPRET DIMENSIONS AND TOLERANCES PER ASME Y14.5.	PROJECTION:
FINISH:	SURFACE FINISH: $\sqrt{32}$ ANGLES: $\pm 1^\circ$	
	TOLERANCES: .X \pm .1 .XX \pm .01 .XXX \pm .005	
	DRAWN: B.MURPHY DT: 26-JUL-17	
	ENGR: D.VARATHARAJAN DT: 18-AUG-17	

SIZE	DWG. NO.	REV
B	CSI-RGFI-ccc-UFFR-p	B
SCALE: 2.5:1	DO NOT SCALE DRAWING	SHEET 1 OF 1