

REVISIONS					
P	LTR REV	DESCRIPTION MODIFICATIONS	DATE	DWN DESS.	APVD APP.
	A	CREATION	08NOV2023	JB	GN

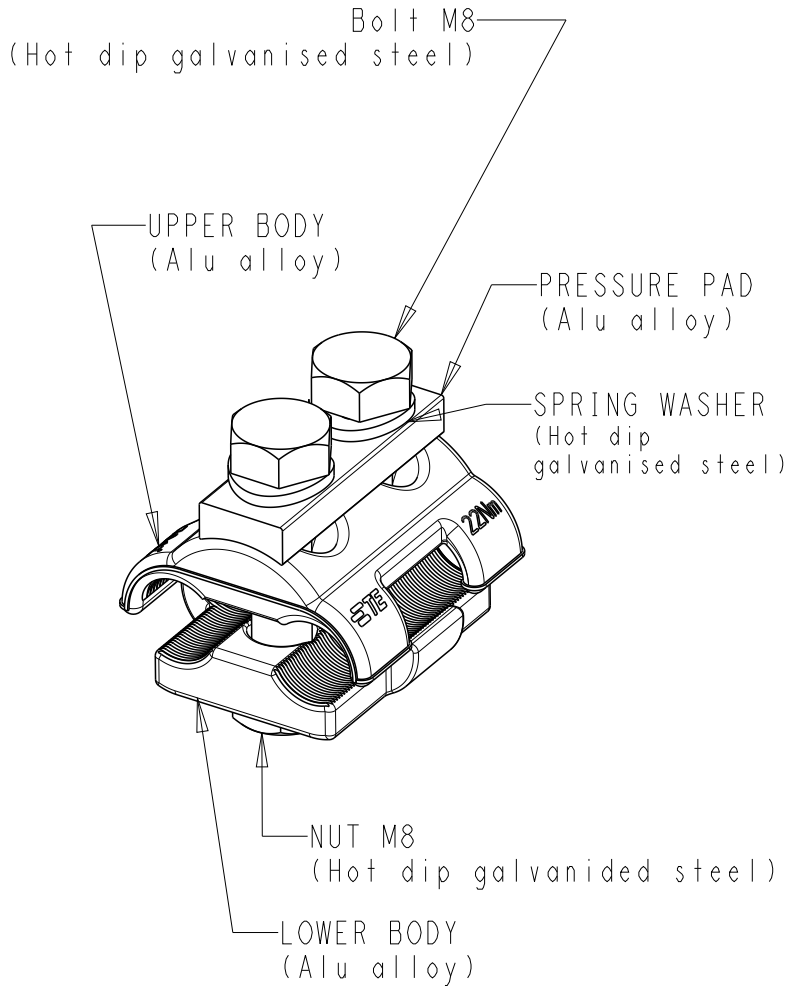
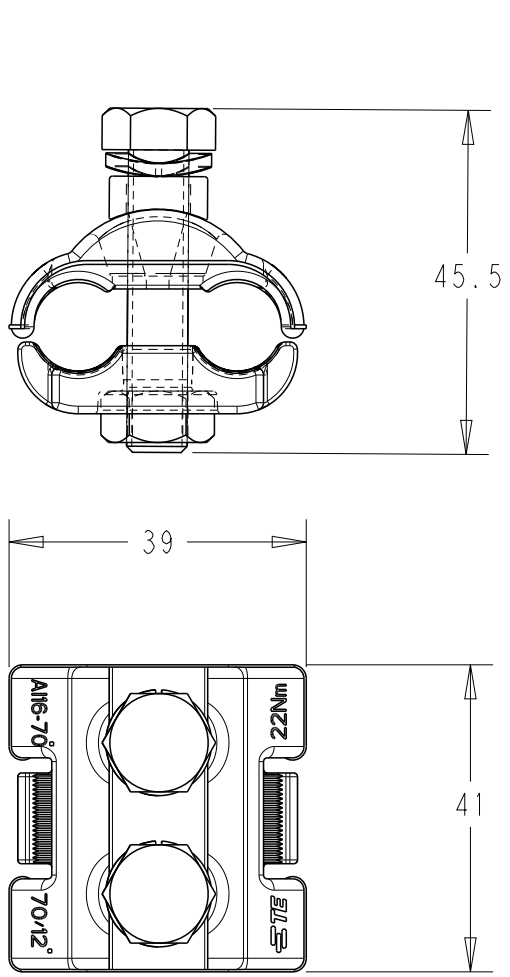

Capacities: 16-70mm² AL
Tightening torque: 22Nm

HEL-3929	169286-000
DESCRIPTION	PART NUMBER

LIBRE A LA DIFFUSION
TOUS DROITS RESERVES.

© 2023 TE Connectivity. All Rights Reserved.
DIFFUSION RESTREINTE

TOLERANCES UNLESS OTHERWISE SPECIFIED: -
TOLERANCES NON SPECIFIEES: -

DIMENSIONS: mm	DWN /DESSINE J. BERLAND 08NOV2023	MATERIAL MATIERE	FINISH FINITION		
<p>TOLERANCES UNLESS OTHERWISE SPECIFIED: TOLERANCES NON SPECIFIEES (SUIVANT DE DECIMALES):</p> <p>0 PLC /DEC: ±0 1 PLC /DEC: ±0.1 2 PLC /DEC: ±0.2 3 PLC /DEC: ±0.3 4 PLC /DEC: ±0.4</p> <p>ANGLES ±</p>	CHK /VERIFIE G. NEDELLEC				
	APVD /APPROUVE A. GUICHARD				
	PRODUCT SPEC SPEC. PRODUIT	NAME TITRE	HEL-3929		
	APPLICATION SPEC SPEC. APPLICATION	SIZE FORMAT	CAGE CODE	DRAWING NO No PLAN	RESTRICTED TO RESERVE A
WEIGHT MASSE APPROX.			HEL-3929		
CUSTOMER DRAWING /PLAN CLIENT		UNIQUEMENT POUR REFERENCE	SCALE ECHELLE 1:1	SHEET FEUILLE 1 OF DE 1	REV A