

REVISIONS					
REV.	ECN#	ZONE	DESCRIPTION	CHANGED BY/DATE	APPROVED BY/DATE
F01	ECN-IAS-03410		INITIAL RELEASED	YS TAN/ 12NOV14	HANG / 12NOV14
F02	ECN-IAS-03577		CORRECTION ON GAIN VALUE	YS TAN/ 21JAN15	HANG / 21JAN15

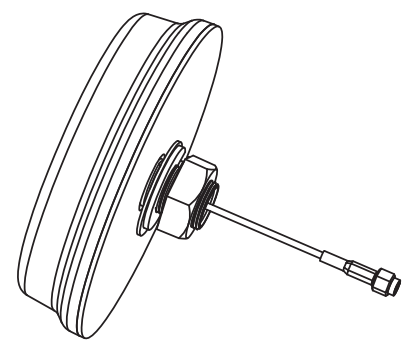
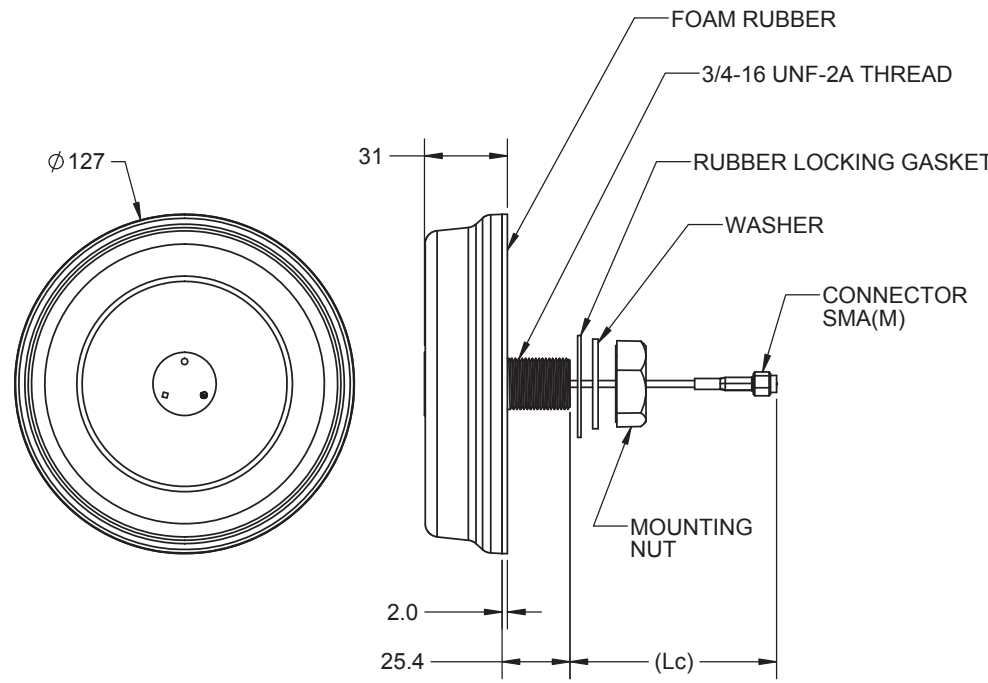

Parameter	Performance	
TE Part Number	LPS69223NT-61SMAM	
Antenna Type	SISO Omni	
Connector Type	SMA(M)	
Cable Type	RG316	
Pigtail Length, Lc	610mm±15mm	
Operating Frequency Range	698-960MHz / 1710-2170MHz	
Gain (dBi)*	On Metal Housing: 2.3 (typical), 2.9 (max) @ 700 Band 1.4 (typical), 1.8 (max) @ 850 Band 1.9 (typical), 2.1 (max) @ 900 Band 4.1 (typical), 4.5 (max) @1800 Band 4.0 (typical), 4.3 (max) @ 1900 Band 3.9 (typical), 4.3 (max) @2100 Band	On Plastic Housing with hardware kit: 2.9 (typical), 3.4 (max) @ 700 Band 1.9 (typical), 2.2 (max) @ 850 Band 2.3 (typical), 2.7 (max) @ 900 Band 4.7 (typical), 5.2 (max) @ 1800 Band 3.9 (typical), 4.3 (max) @ 1900 Band 3.0 (typical), 4.3 (max) @ 2100 Band
Azimuth Beam Width(deg)	Omni-directional	
VSWR Max	3.0:1	
Polarization	Linear, Omnidirectional	
Max Power (watts)	10W	
Antenna Weight	Approximately 0.2Kg	
Storage Temperature Range (°C)	-40 to +85	
Operational Temperature Range (°C)	-30 to +70	
Outdoor Rated	Yes, IP67	
Radome	PC, UL94 V-0 Rating, Black	
RoHS	Yes	

Note:  
 - \*Metal housing test condition is represented by a 300mm diameter aluminum plate. For plastic housing with hardware kit test condition, it is represented by a 260x260x2.7mm plastic plate placed over a 300mm diameter aluminum plate.  
 - Patent Pending.

THIS DRAWING IS UNPUBLISHED.      RELEASED FOR PUBLICATION - , -  
 © Copyright 2022 TE Connectivity Ltd.      ALL RIGHTS RESERVED.

MATERIAL: N/A	THIRD ANGLE PROJECTION		
FINISH: N/A	DO NOT SCALE DRAWING		
APPROVALS	DATE	TITLE: <b>LPS69223NT-61SMAM</b>	
DRAWN BY: YS TAN	13OCT14	INTERPRET DIMENSIONING AND TOLERANCING IN ACCORDANCE WITH ASME Y14.5M-2009 <b>TOLERANCES UNLESS OTHERWISE SPECIFIED</b> DIMENSIONS ARE IN MILLIMETERS	
ELEC. ENG. XW TEOH	13OCT14		
MECH. ENG. YS TAN	13OCT14		
MFG./OPS. CH FONG	13OCT14		
ANGLE: ±30' 0 PLACE DECIMAL: ±0.5 1 PLACE DECIMAL: ±0.25 2 PLACE DECIMAL: ±0.13 SURFACE ROUGHNESS 1.6/		SIZE <b>A3</b> DWG. NO. <b>LPS69223NT-61SMAMMO</b> REV <b>F02</b>	
		SCALE: 1:2 PREVIOUS#	SHEET 1 OF 1