

REVISIONS

P	LTR	DESCRIPTION	DATE	DWN	APVD
	A	INITIAL	14NOV2019	DW	CW
	A1	ECR-20-008707	17JUN2020	DW	CW
	B	ECR-21-111798	07OCT2021	WQR	CW

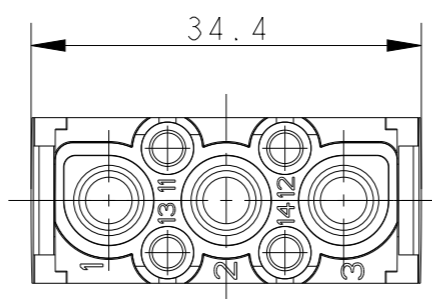
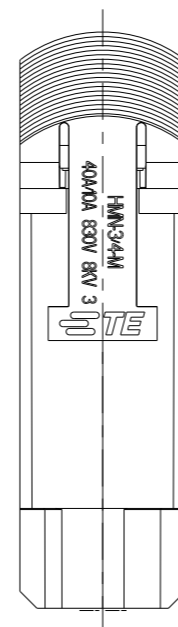
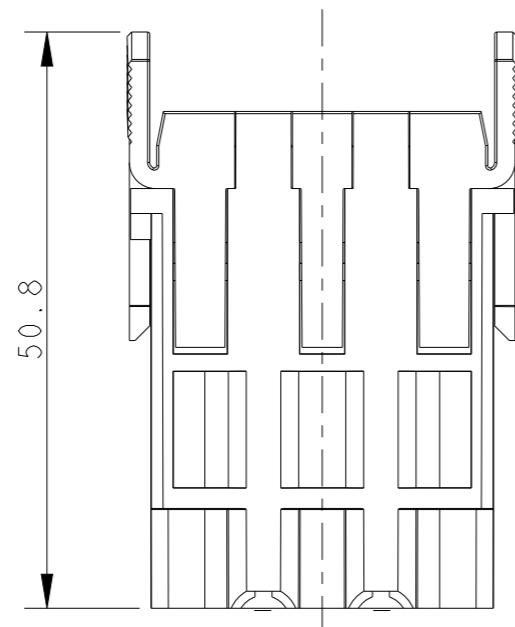
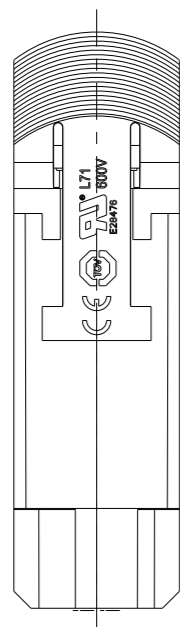
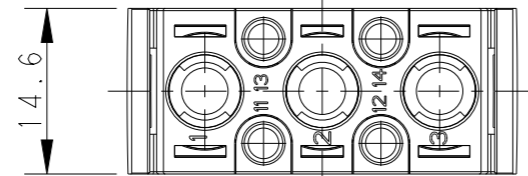
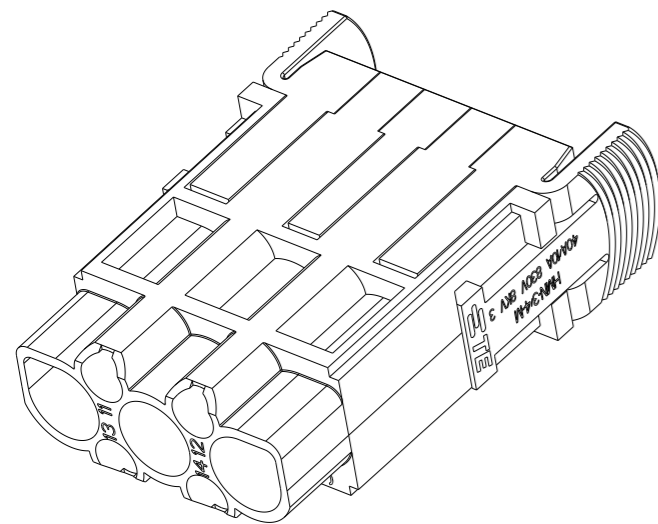

NOTES:

- TECHNICAL CHARACTERISTICS:
 INSULATION MATERIAL: PC
 RATED VOLTAGE: POWER: 830V; SIGNAL: 830V
 RATED CURRENT: POWER: 40A; SIGNAL: 10A
 INSULATION RESISTANCE: $\geq 400M\Omega$
 RATED IMPULSE VOLTAGE: POWER: 8KV; SIGNAL: 8KV
 POLLUTION DEGREE: 3
 FLAMMABILITY: UL94V-0
 MATING CYCLES: 500 CYCLES
 TEMPERATURE RANGE: $-40\sim+125^{\circ}C$
 WIRE RANGE: POWER: 1~6 mm² (18~10 AWG)
 SIGNAL: 0.14~2.5 mm² (26~14 AWG)
 CONTACT TYPE: CRIMP CONTACT
- CONTACT NEED TO BE ORDERED SEPARATELY.
 (ORDER No. REFER TO DRAWING:
 T20400X10XX000 FOR POWER;
 T20200X10XX000 FOR SIGNAL)

注释:

- 技术参数:
 绝缘材料: PC
 额定电压: 电源: 830V; 信号: 830V
 额定电流: 电源: 40A; 信号: 10A
 绝缘电阻: $\geq 400M\Omega$
 额定脉冲电压: 电源: 8KV; 信号: 8KV
 污染等级: 3
 阻燃等级: UL94V-0
 插拔次数: 500次
 温度范围: $-40\sim+125^{\circ}C$
 接线范围: 电源: 1~6 mm² (18~10 AWG)
 信号: 0.14~2.5 mm² (26~14 AWG)
 接线类型: 冷压接
- 端子需要单独订购。
 (订货号参考图面: 电源端子: T20400X10XX000; 信号端子: T20200X10XX000)

T2111342101-000	HMN-3/4-M	HMN-3/4 MALE MODULE INSERT HMN-3/4 模块公插
PART NUMBER 料号	PART DESCRIPTION 描述	

THIS DRAWING IS A CONTROLLED DOCUMENT.		DWN 11 JUL 2019 DAVID WANG				
		CHK 11 JUL 2019 GINO YAO				
		APVD 11 JUL 2019 CHRIS WANG				
		NAME HMN-3/4-M				
DIMENSIONS: mm	TOLERANCES UNLESS OTHERWISE SPECIFIED:	PRODUCT SPEC 108-137418	SIZE	CAGE CODE	DRAWING NO	RESTRICTED TO
	0 PLC \pm - 1 PLC \pm - 2 PLC \pm - 3 PLC \pm - 4 PLC \pm - ANGLES \pm -	APPLICATION SPEC 114-137418	A3	00779	©-T2111342101000	-
MATERIAL	FINISH	WEIGHT	SCALE 3:2		SHEET 1 OF 1	REV B
-	-	-	CUSTOMER DRAWING			