



SPLICE FOR FINE ALUMINUM MAGNET WIRE

Product Flyer

PRODUCT DESCRIPTION

TE Connectivity's (TE) new fine aluminum (Al) magnet wire splice accommodates wires of 0.14 to 0.32mm. This addresses the needs of a growing number of motor and solenoid manufacturers who are switching to fine (<0.32mm) Al magnet wires to reduce product cost and weight. Prior to introduction of this splice, traditional soldering/welding processes were still being used for terminations of these wires, as existing AMPLIVAR splices could only accommodate Al wires larger than 0.32mm. This new open barrel, pigtail splice fills the gap at the lower end of the AMPLIVAR splice size range. It can accommodate up to three fine Al magnet wires plus a copper stranded lead wire (400 to 1500 CMA total). By converting to this new splice applied with an APT-5A terminating machine, customers using fine Al magnet wire can eliminate traditional soldering/welding, reducing labor and improving efficiency with our IDC crimp technology.

FEATURES & BENEFITS

- Accommodate up to three fine Al magnet wires plus a copper stranded lead wire (400 to 1500 CMA total) in a single splice for efficient connectivity.
- Improve production efficiency with IDC compression crimp feature that does not require pre-stripping of magnet wires. It penetrates the magnet wire insulation while simultaneously terminating wire.
- Help reduce applied cost and increase connection reliability by eliminating possible errors such as cold solder joints, weld burns and wire embrittlement that might occur during soldering/welding.
- Enable higher production rates with precision formed and strip-fed splices applied with APT-5A terminating machine.
- Provides a mechanically strong, superior electrical connection free of contaminants such as stripper residue and solder flux.

Splice for Fine Aluminum Magnet Wire

Product Flyer

APPLICATIONS

- Washing machine motors
- Fan motors
- Step motors
- Pumps
- Blenders
- Mixers
- Food processors
- Can openers
- Hair dryers
- Hair clippers / trimmers
- Other small motors
- Solenoids

TECHNICAL DETAILS

- Part Number: 2825180-2
- Voltage: According to applied wire.
- Current: According to applied wire.
- Temperature Range: -65°C to +150°C
- Material: Brass, tin-plated

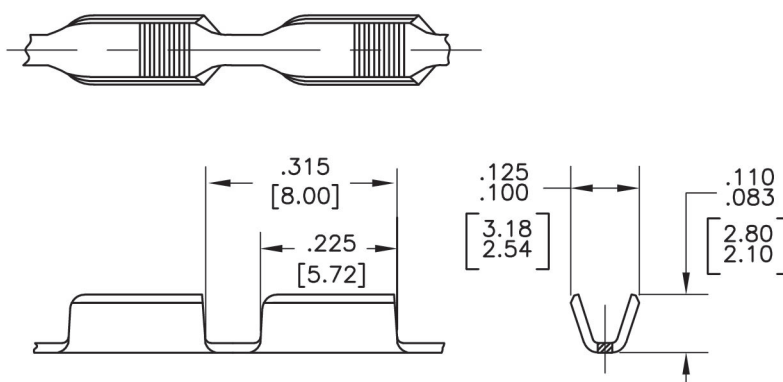

ADDITIONAL RESOURCES

- [Product Spec 108-64051](#)
- [Application Spec 114-64001](#)
- [Customer Drawing](#)

ORDERING INFORMATION

Part Number	Part Description
2825180-2	Splice for Fine Aluminum Magnet Wire

APPLICATION TOOLING

Part Number	Part Description
1-2161800-3	APT-5A terminating machine

Splice for Fine Aluminum Magnet Wire

Product Flyer

CURRENT, RESISTANCE AND CRIMP TENSILE SPECIFICATIONS FOR 2825180-2

Wire Size			Current & Resistance			Tensile Strength [lbs]
AWG	mm	CMA	Current [A] / T-Rise	Current [A] / Cycled	Low Level Resistance	
28	0.32	159	2.0	3.5	28.9	0.90
28.5	0.30	144	1.8	3.2	32.5	0.84
29	0.29	128	1.7	3.0	36	0.77
29.5	0.27	115	1.5	2.6	41	0.69
30	0.25	100	1.3	2.3	46	0.60
30.5	0.24	90	1.0	1.8	52	0.54
31	0.23	79	0.7	1.3	58	0.48
32	0.20	64	0.6	1.0	72	0.39
33	0.18	50	0.4	0.7	91.5	0.30
33.5	0.17	45	0.3	0.5	104	0.27
34	0.16	40	0.2	0.3	116	0.24
35	0.14	31	0.1	0.2	146	0.19

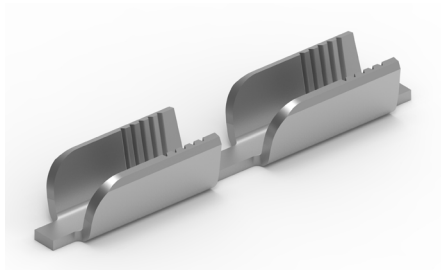

Splice for Fine Aluminum Magnet Wire

Product Flyer

TE TECHNICAL SUPPORT CENTER

USA:	+1 (800) 522-6752
Canada:	+1 (905) 475-6222
Mexico:	+52 (0) 55-1106-0800
Latin/S. America	+54 (0) 11-4733-2200
Germany:	+49 (0) 6251-133-1999
UK:	+44 (0) 800-267666
France:	+33 (0) 1-3420-8686
Netherlands:	+31 (0) 73-6246-999
China:	+86 (0) 400-820-6015

te.com

TE Connectivity, TE Connectivity (logo), AMPLIVAR and Every Connection Counts are trademarks. All other logos, products and/or company names referred to herein might be trademarks of their respective owners.

The information given herein, including drawings, illustrations and schematics which are intended for illustration purposes only, is believed to be reliable. However, TE Connectivity makes no warranties as to its accuracy or completeness and disclaims any liability in connection with its use. TE Connectivity's obligations shall only be as set forth in TE Connectivity's Standard Terms and Conditions of Sale for this product and in no case will TE Connectivity be liable for any incidental, indirect or consequential damages arising out of the sale, resale, use or misuse of the product. Users of TE Connectivity products should make their own evaluation to determine the suitability of each such product for the specific application.

© 2016 TE Connectivity Ltd. family of companies All Rights Reserved.

1-1773896-1 09/22 Original