

Table of Contents

Double Pole, Electrically Held, 1 Amp and Less	
MAV, MAVD, MAVDD	3-2, 3-3
MSV, MSVD	3-4, 3-5

Double Pole, Electrically Held, 1 Amp and Less

MAV, MAVD, MAVDD

MAV
Standard
High Vibration TO-5
High Performance Relay

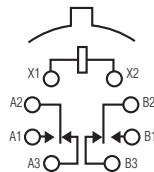

Terminal View

MAVD
Standard
High Vibration TO-5
Diode Suppressed
High Performance Relay

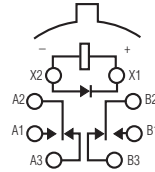

Terminal View

MAVDD
Standard
High Vibration TO-5
Diode Suppressed/
Protected
High Performance Relay

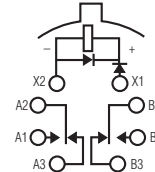

Terminal View

Product Facts

- Hermetically sealed
- Extreme shock & vibration ratings
- Spreader pads

Product Facts

- Suppression diode
- Hermetically sealed
- Extreme shock & vibration ratings
- Spreader pads

Product Facts

- Suppression & protection diodes
- Hermetically sealed
- Extreme shock & vibration ratings
- Spreader pads

Electrical Characteristics

Contact Arrangement —
2 Form C (DPDT)

Contact Material —
Stationary —
Gold/platinum/palladium/silver alloy
(Gold plated)
Moveable — Gold/platinum/palladium/
silver alloy (Gold plated)

Contact Resistance —
Before Life — 100 milliohms max.
(measured @ 10 mA @ 6 Vdc)
After Life — 200 milliohms max.
(measured @ 1 A @ 28 Vdc)

Mechanical Life Expectancy —
1 million operations

Coil Voltage — 5 to 26.5 Vdc

Coil Power — 820 mW max. @ 25°C

Duty Cycle — Continuous

Pick-up Voltage — Approximately
70% of Nominal Coil Voltage

Pick-up Sensitivity — 370 mW max.
@ 25°C

Contact Ratings

Contact Load	Type	Operations Min.
1.0 A @ 28 Vdc	Resistive	100,000
250 mA @ 115 Vac, 60 Hz & 400 Hz	Resistive (Case not grounded)	100,000
100 mA @ 115 Vac, 60 Hz & 400 Hz	Resistive	100,000
0.2 A @ 28 Vdc	Inductive (0.32 Henry)	100,000
0.1A @ 28 Vdc	Lamp	100,000
30 μA @ 50 mVdc	Low Level	1,000,000
0.1 A @ 28 Vdc	Intermediate Current	50,000

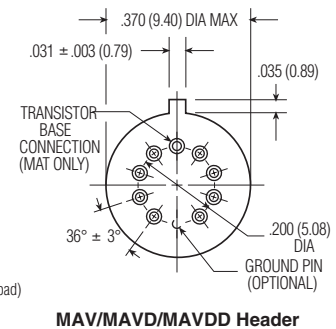
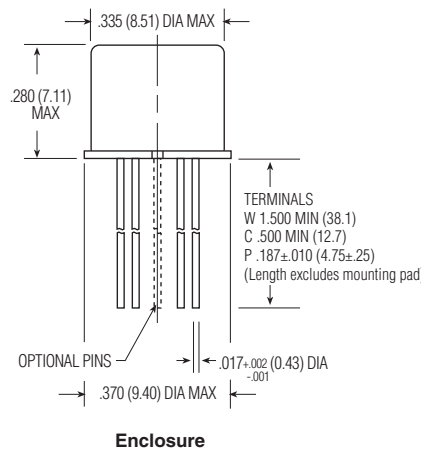

MAV/MAVD/MAVDD Header

Double Pole, Electrically Held, 1 Amp and Less (Continued)

MAV, MAVD, MAVDD

(Continued)

Operating Characteristics

Operate Time — 2.0 ms max.

Release Time —

MAV — 1.5 ms max.

MAVD / MAVDD — 4.0 ms max.

(suppression diode, suppression/steering diodes)

Contact Bounce — 1.5 ms max.

Dielectric Withstanding Voltage —

Between Open Contacts —

500 Vrms 60 Hz

Between Adjacent Contacts —

500 Vrms 60 Hz

Between Contacts and Coil —

500 Vrms 60 Hz

Insulation Resistance —

10,000 megohms min. @ 500 Vdc

1,000 megohms @ 500 Vdc (coil to case at +125°C)

Environmental Characteristics

Temperature Range —

-65°C to +125°C

Weight —

0.09 oz. (2.55 grms)

0.10 oz. (2.80 grms) with spreader pad attached

Vibration Resistance —

100 G's, 10 - 2,000 Hz

250 G's, 140 +/- 5 Hz

350 G's, 170 +/- 5 Hz

380 G's, 200 +/- 5 Hz

Shock Resistance —

150 G's, 11 ± 1ms max.

Semiconductor Characteristics

Diode —

100 Vdc peak inverse voltage (PIV)

1.0 Vdc max. transient voltage

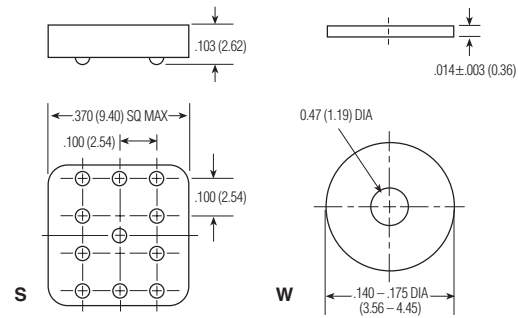

Spreader & Mounting Pads

Coil Data

Nom. Coil Voltage (Vdc)	Coil Resistance in Ohms ±10% @ 25°C (Note 1)	Coil Circuit Current mA (Max.) (Note 1)	Coil Circuit Current mA (Min.) (Note 1)	Pickup Voltage Vdc (Max.) @ 25°C	Pickup Voltage Vdc (Max.) @ 125°C	Drop-Out Voltage Vdc (Min.) @ 25°C	Drop-Out Voltage Vdc (Min.) @ -65°C	Nom. Coil Power (mW) @ 25°C	Max. Coil Voltage	Coil Desig.
MAV										
5.0	50	n/a	n/a	3.5	4.6	0.22	0.14	500	5.8	5
6.0	70	n/a	n/a	4.0	5.5	0.28	0.18	514	8.0	6
9.0	155	n/a	n/a	5.9	8.2	0.54	0.35	523	12.0	9
12.0	235	n/a	n/a	8.0	11.0	0.63	0.41	613	16.0	12
18.0	610	n/a	n/a	11.9	16.5	0.91	0.59	531	24.0	18
26.5	1,130	n/a	n/a	15.9	22.0	1.37	0.89	621	32.0	26
MAVD										
5.0	33	n/a	n/a	3.5	4.6	0.22	0.14	758	5.8	5
6.0	44	n/a	n/a	4.0	5.5	0.28	0.18	818	8.0	6
9.0	125	n/a	n/a	5.9	8.2	0.54	0.35	648	12.0	9
12.0	215	n/a	n/a	8.0	11.0	0.63	0.41	670	16.0	12
18.0	470	n/a	n/a	11.9	16.5	0.91	0.59	689	24.0	18
26.5	1,050	n/a	n/a	15.9	22.0	1.37	0.89	669	32.0	26
MAVDD										
5.0	33	126.4	92.8	3.5	4.6	0.6	0.6	758	5.8	5
6.0	44	122.6	90.4	4.0	5.5	0.7	0.7	818	8.0	6
9.0	125	73.4	54.3	5.9	8.2	0.9	0.8	648	12.0	9
12.0	215	59.4	37.8	8.0	11.0	1.1	0.9	670	16.0	12
18.0	470	42.0	31.3	11.9	16.5	1.4	1.1	689	24.0	18
26.5	1,050	28.3	21.3	15.9	22.0	1.8	1.4	669	32.0	26

Note: 1. Coil resistance not directly measurable in MAVDD series.

Coil current should be within limits shown when tested at nominal voltage at 25°C for 5 seconds maximum.

HOW TO SPECIFY A PART NUMBER

For our standard catalog High Performance products, the Part Number begins with the series designator shown below.

Specifying a Part Number Example:	Series	Terminals	Diodes	Ground Pins	Coils	Spreader/ Mounting Pads
	MAV	C	D	G	-26	S

Double Pole, Electrically Held, 1 Amp and Less (Continued)

MSV, MSVD

MSV
Sensitive
High Vibration TO-5
High Performance Relay

MSVD
Sensitive
High Vibration TO-5
Diode Suppressed
High Performance Relay

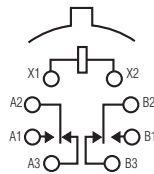

Terminal View

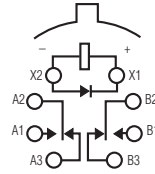

Terminal View

Product Facts

- Hermetically sealed
- Extreme shock & vibration ratings
- Spreader pads

Product Facts

- Suppression diode
- Hermetically sealed
- Extreme shock & vibration ratings
- Spreader pads

Electrical Characteristics

Contact Arrangement —
2 Form C (DPDT)

Contact Material —
Stationary —
Gold/platinum/palladium/silver alloy
(Gold plated)
Moveable — Gold/platinum/palladium/
silver alloy (Gold plated)

Contact Resistance —
Before Life — 100 milliohms max.
(measured @ 10 mA @ 6 Vdc)
After Life — 200 milliohms max.
(measured @ 1 A @ 28 Vdc)

Mechanical Life Expectancy —
1 million operations

Coil Voltage — 5 to 26.5 Vdc

Coil Power — 370 mW max. @ 25°C

Duty Cycle — Continuous

Pick-up Voltage — Approximately
70% of Nominal Coil Voltage

Pick-up Sensitivity — 155 mW max.
@ 25°C

Contact Ratings

Contact Load	Type	Operations Min.
1.0 A @ 28 Vdc	Resistive	100,000
250 mA @ 115 Vac, 60 Hz & 400 Hz	Resistive (Case not grounded)	100,000
100 mA @ 115 Vac, 60 Hz & 400 Hz	Resistive	100,000
0.2 A @ 28 Vdc	Inductive (0.32 Henry)	100,000
0.1A @ 28 Vdc	Lamp	100,000
30 μA @ 50 mVdc	Low Level	1,000,000
0.1 A @ 28 Vdc	Intermediate Current	50,000

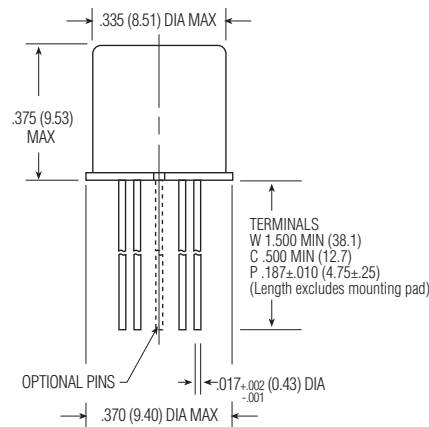

Enclosure

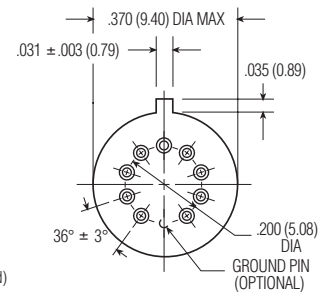

MSV/MSVD Header

Double Pole, Electrically Held, 1 Amp and Less (Continued)

MSV, MSVD (Continued)

Operating Characteristics

Operate Time — 4.0 ms max.

Release Time —

MSV — 2.0 ms max.

MSVD — 7.5 ms max.

(suppression diode)

Contact Bounce — 1.5 ms max.

Dielectric Withstanding Voltage —

Between Open Contacts —

500 Vrms 60 Hz

Between Adjacent Contacts —

500 Vrms 60 Hz

Between Contacts and Coil —

500 Vrms 60 Hz

Insulation Resistance —

10,000 megohms min. @ 500 Vdc

1,000 megohms @ 500 Vdc (coil to case at +125°C)

Environmental Characteristics

Temperature Range —

-65°C to +125°C

Weight —

0.09 oz. (2.55 grms)

0.10 oz. (2.80 grms) with spreader pad attached

Vibration Resistance —

100 G's, 10 - 2,000 Hz

250 G's, 140 +/- 5 Hz

350 G's, 170 +/- 5 Hz

380 G's, 200 +/- 5 Hz

Shock Resistance —

150 G's, 11 ± 1ms max.

Semiconductor Characteristics

Diode —

100 Vdc peak inverse voltage (PIV)

1.0 Vdc max. transient voltage

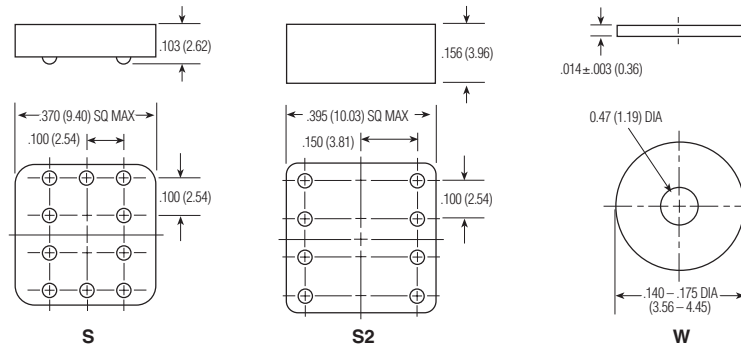

Spreader & Mounting Pads

Coil Data

Nom. Coil Voltage (Vdc)	Coil Resistance in Ohms ±10% @ 25°C	Pickup Voltage Vdc (Max.) @ 25°C	Pickup Voltage Vdc (Max.) @ 125°C	Drop-Out Voltage Vdc (Min.) @ 25°C	Drop-Out Voltage Vdc (Min.) @ -65°C	Nom. Coil Power (mW) @ 25°C	Max. Coil Voltage	Coil Desig.
MSV / MSVD								
5.0	80	3.5	4.6	0.22	0.14	313	5.8	5
6.0	120	4.0	5.5	0.28	0.18	300	8.0	6
9.0	240	5.9	8.2	0.54	0.35	338	12.0	9
12.0	480	8.0	11.0	0.63	0.41	300	16.0	12
18.0	950	11.9	16.5	0.91	0.59	341	24.0	18
26.5	1,900	15.9	22.0	1.37	0.89	370	32.0	26

HOW TO SPECIFY A PART NUMBER

For our standard catalog High Performance products, the Part Number begins with the series designator shown below.

Specifying a Part Number Example:	Series	Terminals	Diodes	Ground Pins	Coils	Spreader/ Mounting Pads
	MSV	C	D	G	-26	S

Engineering Notes

