ELE-3COP-553

Title – Installation and Recovery of Medium and Large Transitions.

Before starting work please read this document carefully and note the guidance given.

1 Purpose and Scope

This COP describes the procedure to be used when installing medium and large transition moulded parts. The instructions in this document take preference over IPC/WHMA requirements, as do the drawing and any customer documentation.

It is good working practice that where trained operators have not installed this product for over 6 months, a sample installation should be carried out by the operator to refresh installation practice. Performance of the sample can be checked using the inspection standards described within this document.

2 Performance Objective

This code of practice is produced to support operators already trained in the installation of heat shrinkable and harnessing products. It identifies the procedure to be used when carrying out the installation and recovery of a medium and large transition using a heat gun. It is intended to recover the transition from its supplied shape and size so that it takes up the required shape whilst gripping the harness branches.

Note

It is recommended that the moulded part chosen for the application is the largest size possible to fit the harness.

Best results will be obtained if 10% unresolved recovery (grip) for all outlets of the moulded parts is available. Please check for compliance with this requirement before assembly. Unresolved recovery is defined as the difference between the installed diameter and the fully shrunk (recovered) diameter as given on the SCD expressed as a percentage of the fully shrunk diameter. For example a moulded part fully shrunk with a diameter of 10mm and an installed diameter of 11mm has a 10% unresolved recovery.

3 Materials and Equipment:

Appropriate transition moulded part

Appropriate adhesive

100 grit Emery Cloth or equivalent

Degreasing Agent Isopropyl alcohol or Isopropanol (IPA) impregnated tissue wipe

Heavy duty tissues

Heat Gun CV1981 or equivalent. Other hot air guns may be used but these must be capable of delivering the temperatures required for installation of the moulded part. This also includes hot air guns with temperature displays.

Reflector PR 26 or equivalent

Heat Shield HS1 (AD-7-025) for /225 only

Bend Test Fixture 500Z1270 (TE)

Heat Resistant Gloves

Safety Glasses

ELE-3COP-553

Title – Installation and Recovery of Medium and Large Transitions

4 Health and Safety

Adhere to local Codes and Regulations relating to Safe Working practices. For the U.K. adhere to requirements of the Health and Safety at Work Act 1974 and subsequent amendments.

The installation should be carried out in a well ventilated area.

Always wear heat resistant safety gloves when handling hot plastics and adhesives.

The use of suitable protective gloves and barrier cream is recommended when using solvents.

Avoid prolonged repeated skin contact with solvents and always wash hands after using solvents.

Care should be taken to wear safety glasses when using and handling chemical solvents. If eyes do become contaminated, flush with water and obtain medical assistance immediately.

Always ensure all equipment is calibrated before use.

5 Procedure

Preparation

For this Code of Practice a 382 series transition is used as an example.

To ensure the best possible bond between the moulded part and the cable jacket:

Degrease the cable jackets in the area where the H, J and K ends will recover onto the cable using Isopropyl alcohol. (Approximately 30mm).

Abrade the cable jacket thoroughly in the same area with 100 grit emery cloth. The whole surface of the cable jacket should be abraded removing any print on the cable jacket. (See Figure 1)

For moulded parts without a pre-installed adhesive degrease the inner part of each leg of the transition where the H, J and K ends will recover onto the cable using Isopropyl alcohol.

Abrade the inner part of each leg of the transition ends H, J and K for a minimum of 20mm.

Remove loose particles from the abraded area using a dry tissue. **DO NOT** use a solvent wipe.

Ensure sufficient cable jacket has been abraded to incorporate the strip length requirement.

Take care to avoid abrading shield that may be exposed.



Figure 1

This part of the cable preparation is very important in ensuring a strong bond to the moulded part.

ELE-3COP-553

Title – Installation and Recovery of Medium and Large Transitions

Installation

Position moulded part centrally onto cableform and heat uniformly, starting from the centre moving outwards towards each breakout in turn. (See Figure 2)

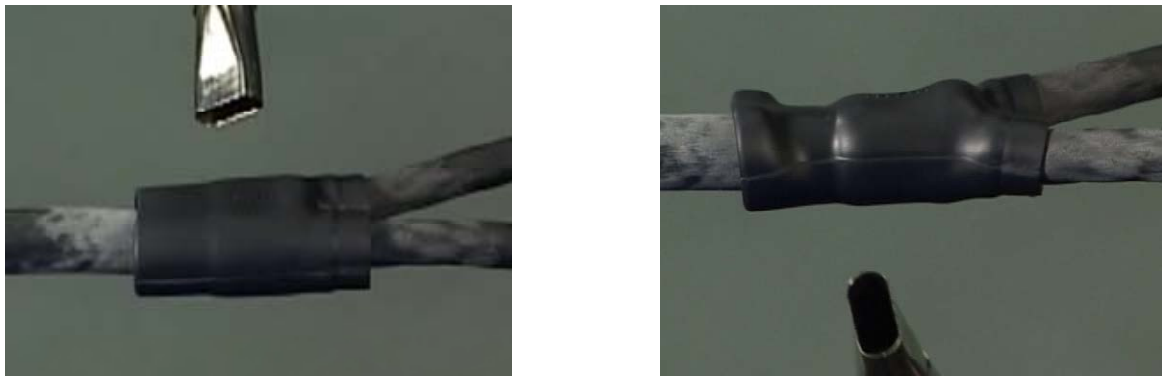

Figure 2

If the moulded part does not have a pre-installed adhesive, before the legs are fully recovered, apply adhesive 360° to both the inner of the moulded part and all cable jackets.

When using /225 moulded parts use the heat shield below to avoid pre-curing of the other moulded part legs. Ensure heat is not aimed into the inside of the moulded part as this may cause pre curing of the adhesive. (See Figure 3)



Figure 3

Continue heating along the moulded part until all ends are fully recovered.

ELE-3COP-553

Title – Installation and Recovery of Medium and Large Transitions



Figure 4

Heat must be applied evenly around the moulded part to recover evenly and prevent scorching.

Ensure the part is fully recovered onto the cable. (See Figure 4)

It may be necessary to re-heat the area between outlets until the required shape has been fully formed. For best results the moulded part should be installed as a continuous operation.

Look for evidence that adhesive is present.

Clean off excess adhesive.

For transitions with pre-installed adhesives refer to the following Codes of Practice for relevant post heat times to ensure the adhesives are activated.

ELE-3COP-559

Installation /225 moulded parts.

ELE-3COP-608

Installation of -100 and -25 Moulded Parts Pre-coated with /86, /42 or /180 Hot Melt Adhesive.

Always ensure that the air vent on the rear of the hot air gun is open and that it is dust free.

Always allow the hot air gun to stabilize at the required temperature and setting for two minutes before commencing calibration and installation.

Setting of the gun should be carried out on a regular basis using the following temperatures.

Frequency will depend on usage. It is recommended that the Heat gun is set daily using a Calibrated thermocouple 25 mm from the end of the reflector within the temperature range stated . Please refer to the Manufacturers guide for Hot Air Gun Calibration and maintenance.

For medium and large transitions set the Hot air gun to 250°C to 280°C.

Allow to stand for recommended adhesive curing cycle before any aggressive handling

ELE-3COP-553

Title – Installation and Recovery of Medium and Large Transitions

6 Inspection Requirements

The termination should be subjected to a Flex Test of 90° in each of the four planes around a mandrel diameter as stated below.

System 25	(FDR25 / DR25 / -25 type)	6 x cable diameter
System 100	(Zerohal / -100 type)	10 x cable diameter
System 200	(Fluoroelastomer / -12 type)	6 x cable diameter
System 10	(Thermorad / RNF100 type)	6 x cable diameter
Convolute system	(HCTE / Convolex type)	6 x cable diameter

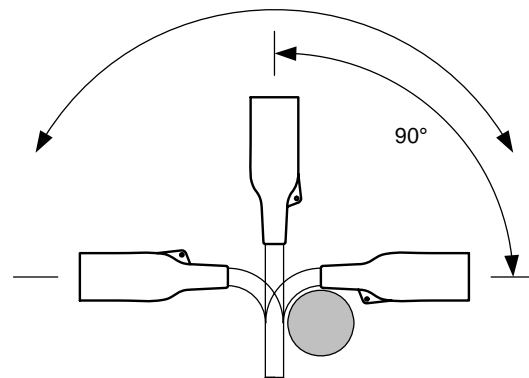

There should be no separation between the moulded part H, J and K end and the cable jacket at the adhesive bond line.

The Moulded Part must be free from fingerprints and scorch marks.

The Moulded Part shall be fully recovered and free from distortion.

7 Visual Standards

Refer to the following documents

ELE-3COP-559

Installation /225 moulded parts.

ELE-3COP-607

Application of Hot Melt tapes

ELE-3COP-604

Use of S1125 adhesive

ELE-3COP-608

Installation of -100 and -25 Moulded Parts Pre-coated with /86, /42 or /180 Hot Melt Adhesive



ELE-3COP-553

Title – Installation and Recovery of Medium and Large Transitions

Rev No	CR No	Date	Raised	Approved
3	CR06-DM-071	03/05/06	Paul Newman	Neil Dorricott
4	CR09-DM-018	03/05/09	John Cronin	Ken Wallington
5	Visual Identity	07/06/11	John Cronin	Ken Wallington

All of the above information is believed to be reliable. Users, however, should independently evaluate the suitability of each product for their application. TE makes no warranties as to the accuracy or completeness of the information and disclaims any liability regarding its use. TE's only obligations are those in the Standard Terms and Conditions of Sale for these products and in no case will TE be liable for any incidental/ indirect or consequential damages arising from the sale, resale, use or misuse of the product. TE Specifications are subject to change without notice. In addition TE reserves the right to make changes in materials or processing, without notification to the Buyer, which do not affect compliance with any applicable specification.