

SEACON 75 Ohm Coax Connectors

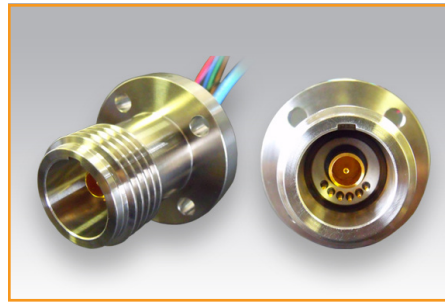

KEY FEATURES

- Available in alternative materials
- Suitable for a variety of applications

Description

Developed in conjunction with a camera manufacturer where a new HD camera required impedance matched coax and signal lines. The Flange Connector Receptacle Long shell (FCRL) has a combination of TE's SEACON MINI-CON (MINL) front end interface, but with a TE's SEACON 5515 FCR mounting interface. The Cable Connector Plug Long shell (CCPL) insert is manufactured from moulded PEEK (Polyetheretherketone) with a 316L stainless steel connector shell. The bulkhead has a glass to metal sealed insert and has been open-face pressure tested to 8,400 psi. This 75 ohm coax connector is also available with the bulkhead having the standard Bulkhead Connector Receptacle Long shell (MINL-BCRL) mounting interface.

DESIGN SPECIFICATION

- Contacts: 1 coax, 6 electrical (22 AWG)
- Recommended coaxial cable or component: RG.6A/U & RG.59B/U
- Pressure tested to 8,400 psi mated & open-face
- Impedance: 75 ohms
- Current: 3-4 amps

NOTE:

This is a dry-mate connector, in open-face exposure, it only operates as a pressure boundary.

TE Components . . . TE Technology . . . TE Know-how . . .

AMP | AGASTAT | CII | HARTMAN | KILOVAC | MICRODOT | NANONICS | POLAMCO | Raychem

SEACON | Rochester | DEUTSCH

Empower Engineers to Solve Problems, Moving the World Forward.

LET'S CONNECT

We make it easy to connect with our experts and are ready to provide all the support you need. Just call your local support number or visit www.te.com/industrial to chat with a Product Information Specialist.

Technical Support

te.com/support-center

US Inside Sales:

Phone: +1 619-562-7071
Email: elcajonsales@te.com

Phone: +1 979-865-8846
Email: bellvillesales@te.com

Phone: +1 401-637-4952
Email: eastcoastsales@te.com

UK Inside Sales:

Phone: +44 (0) 1493-652733
Email: gtymouthsales@te.com

France Inside Sales:

Phone: +33 2 43 61 45 45
Email: offshore-ckb@te.com

Brazil Inside Sales:

Phone: +55 21 3592-0920
Email: simone.carvalho@te.com

North America +1 800 522 6752
North America (Toll) +1 717 986 7777
EMEA/South Africa +800 0440 5100
EMEA (Toll) +31 73 624 6999
India (Toll-Free) +800 440 5100

Asia Pacific +86 400 820 6015
Japan +81 044 844 8180
Australia +61 2 9554 2695
New Zealand +64 (0) 9 634 4580

te.com/MOG

AMP, AGASTAT, CII, DEUTSCH, HARTMAN, KILOVAC, MICRODOT, NANONICS, POLAMCO, Raychem, SEACON, TE, TE Connectivity and the TE connectivity (logo) are trademarks of TE Connectivity. Other products, logos, and company names mentioned herein may be trademarks of their respective owners.

While TE Connectivity (TE) has made every reasonable effort to ensure the accuracy of the information herein, nothing herein constitutes any guarantee that such information is error-free, or any other representation, warranty or guarantee that the information is accurate, correct, reliable or current. The TE entity issuing this publication reserves the right to make any adjustments to the information contained herein at any time without notice. All implied warranties regarding the information contained herein, including, but not limited to, any implied warranties of merchantability or fitness for a particular purpose are expressly disclaimed. The dimensions herein are for reference purposes only and are subject to change without notice. Specifications are subject to change without notice.

Consult TE for the latest dimensions and design specifications.

© 2019 TE Connectivity All Rights Reserved.

2363319-1 12/19

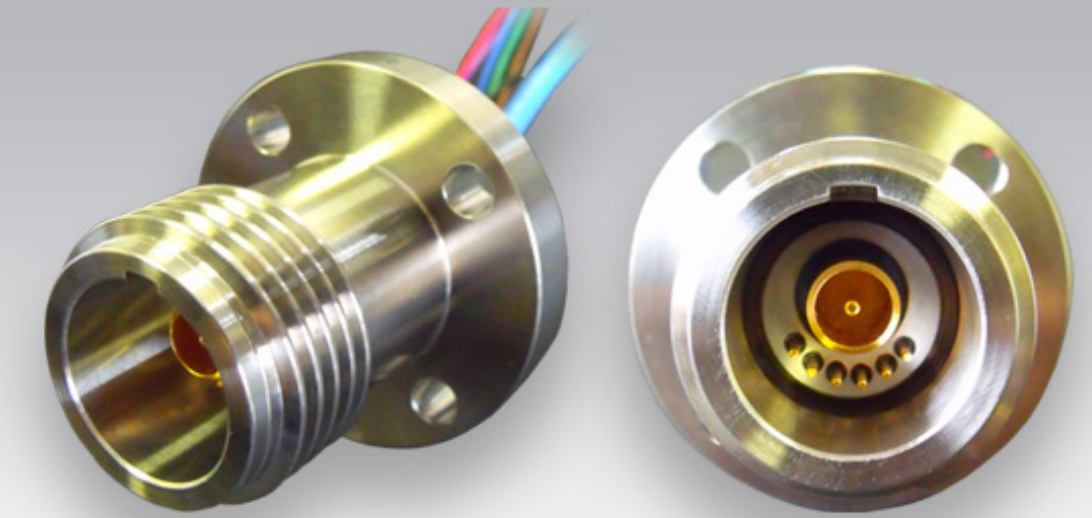

SEACON 75 Ohm Coax Connectors



MINL-CCPL - 1 Coax/6 Electric Molded Straight

MINI-CON Cable Connector Plug Long

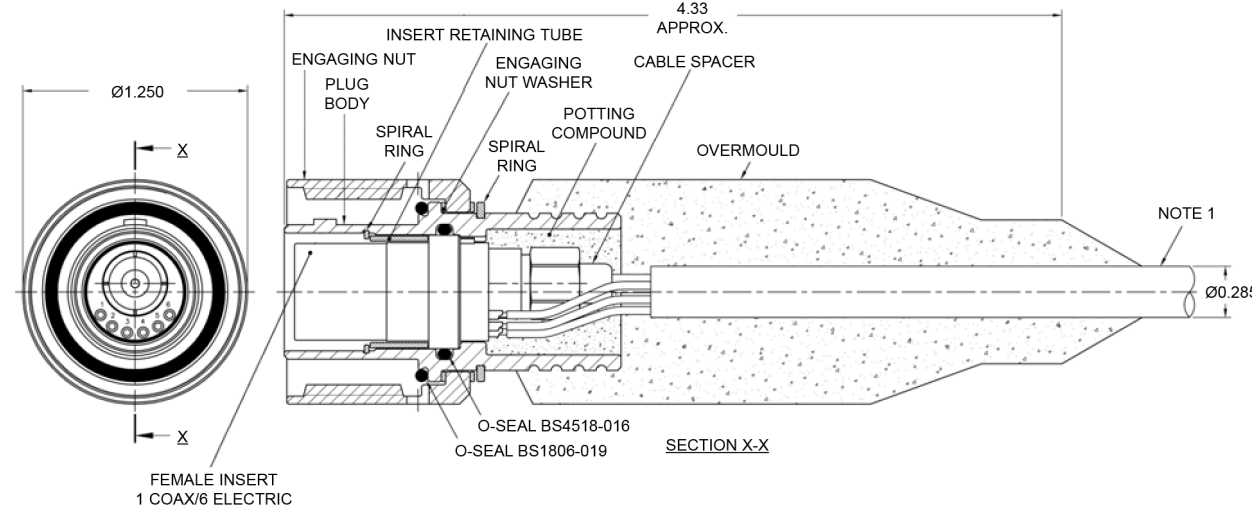

Notes:

1 - Connector supplied with 75 Ohm Coax / 9 Core Cable as standard unless otherwise specified on customer purchase order.



MINL-BCRL - 1 Coax/6 Electric

MINI-CON Bulkhead Connector Receptacle Long

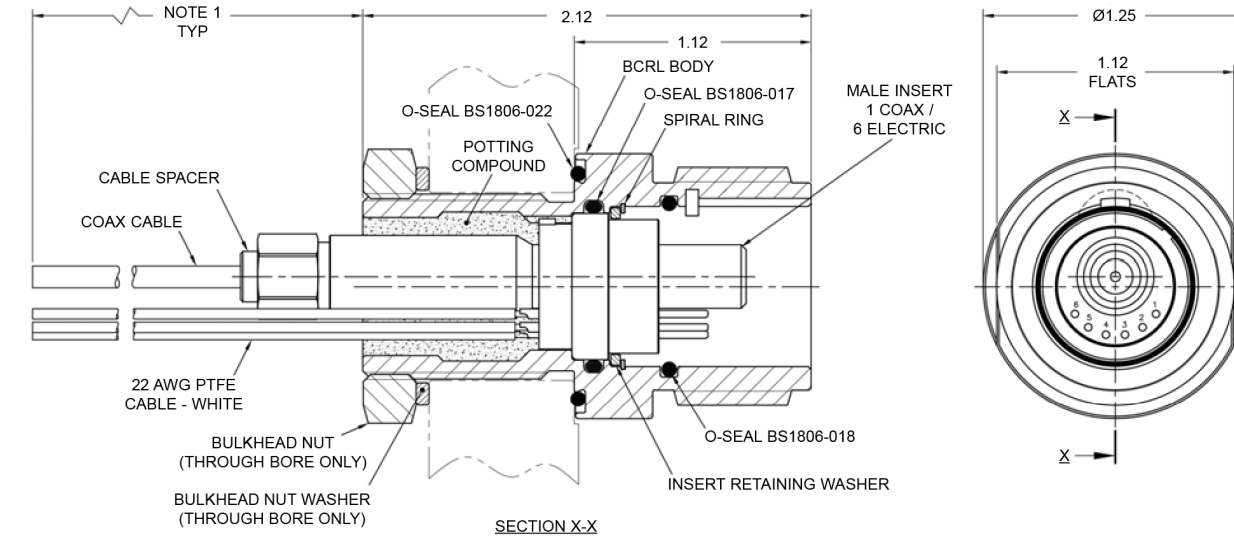

BCR Through Bore Mounting Option Utilising Bulkhead Nut and Washer

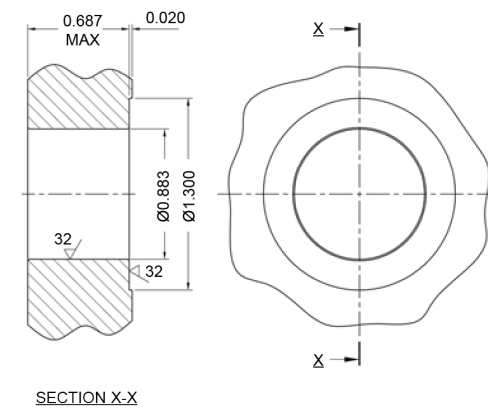

BCR Thread Mounting Option

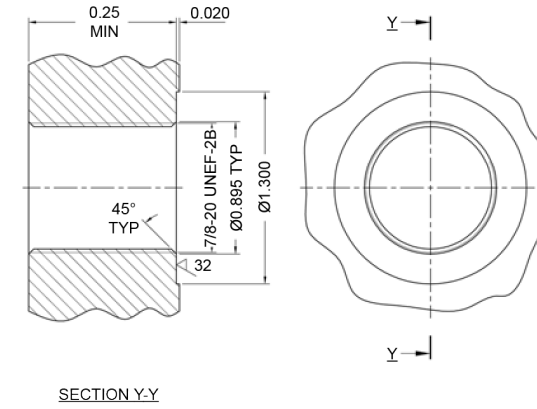

MINL-FCRL - 1 Coax/6 Electric (55 Series Size 15 Interface)

MINI-CON Flange Connector Receptacle Long

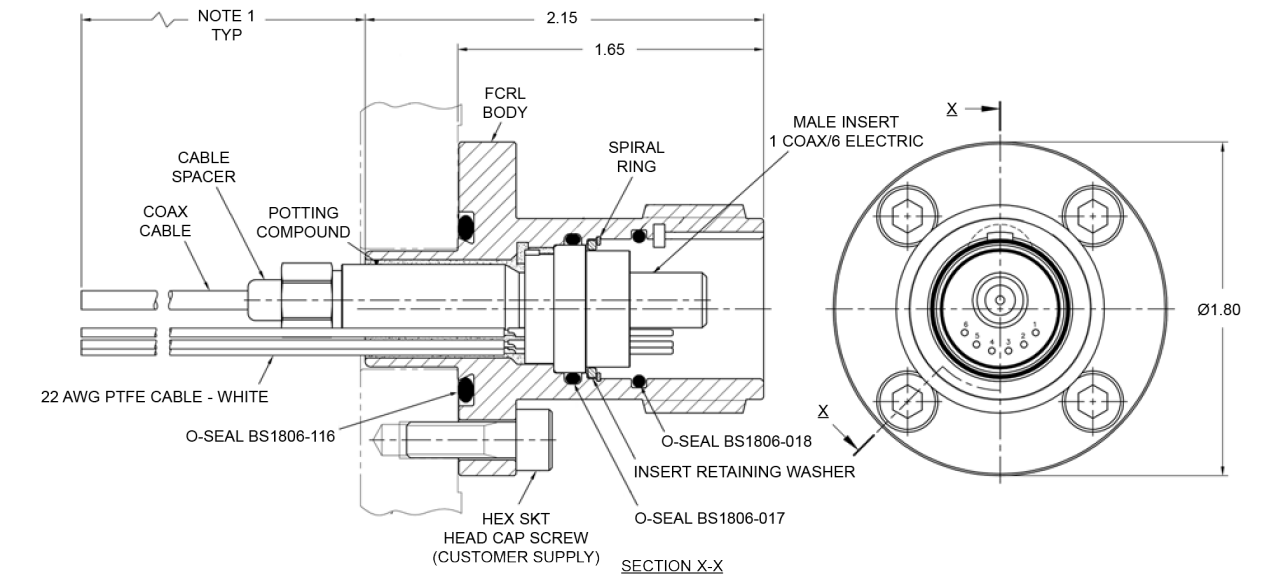

FCR Mounting Information

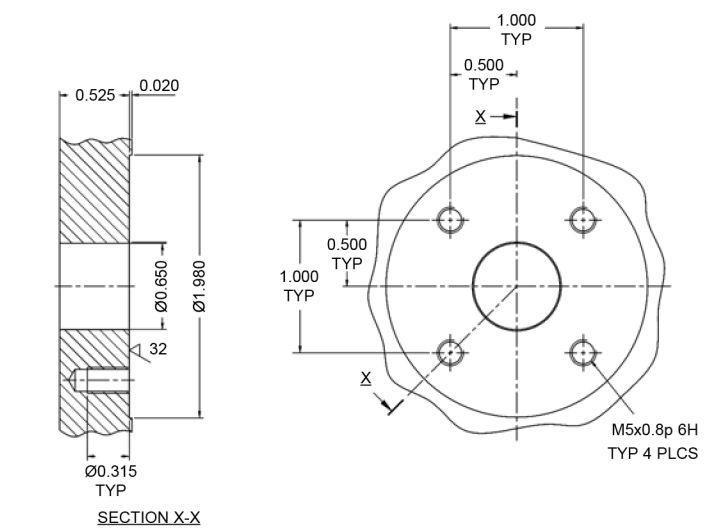

Notes:

1 - Cable tail length to be specified on purchase order.