

THIS DRAWING IS UNPUBLISHED. RELEASED FOR PUBLICATION OCT. 2001.
 © COPYRIGHT 2001 By - ALL RIGHTS RESERVED.

LOC	DIST	REVISIONS			
P	LTR	DESCRIPTION	DATE	DWN	APVD
J	/				
	K3	REVISED PER ECO-11-005033	28MAR11	RK	HMR

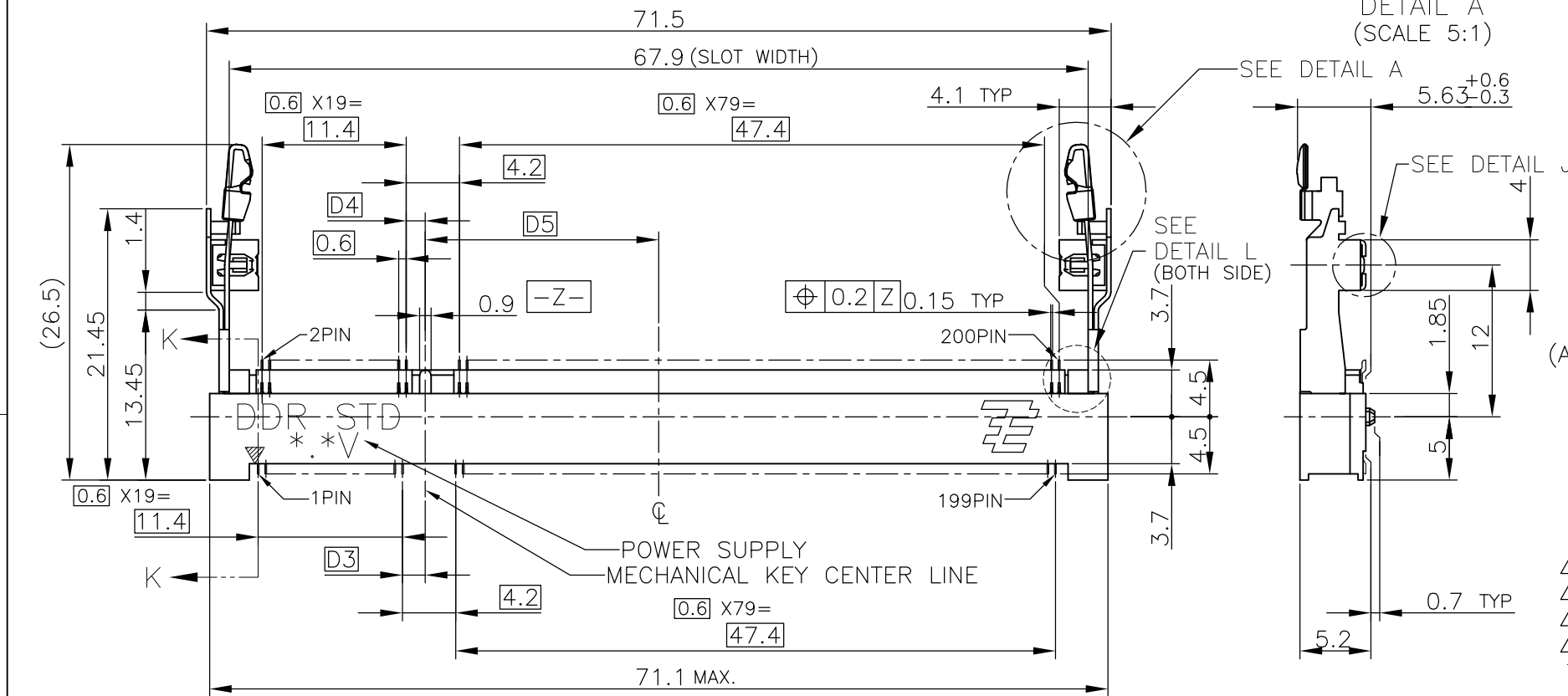

HOW TO MATE AND UNMATE
 MATE: ① → ④
 UNMATE: ⑤ → ⑦

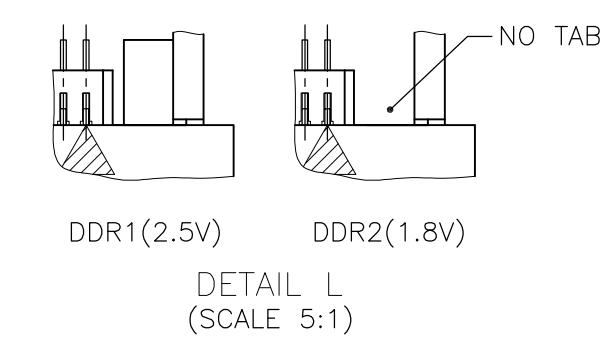
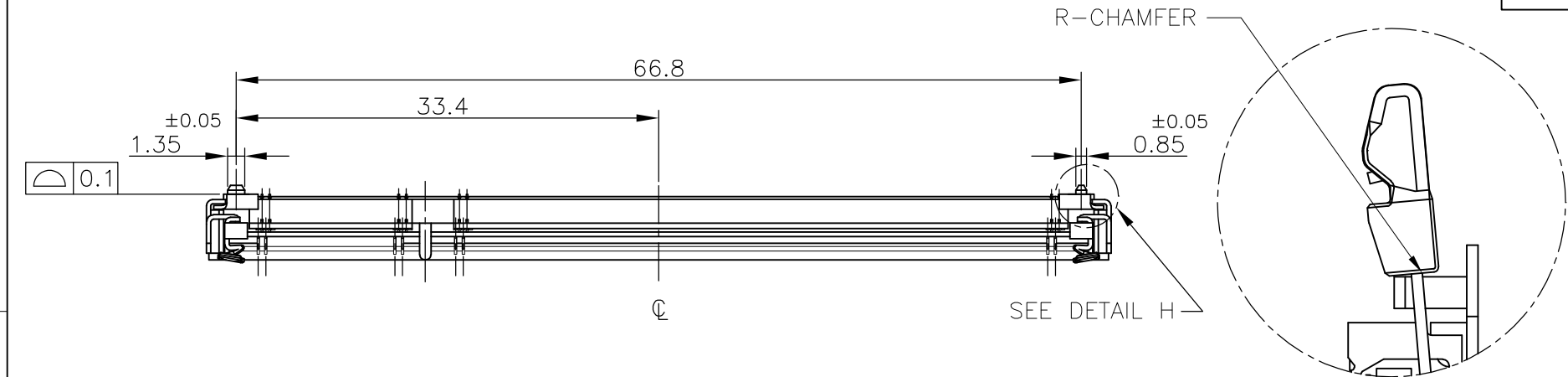
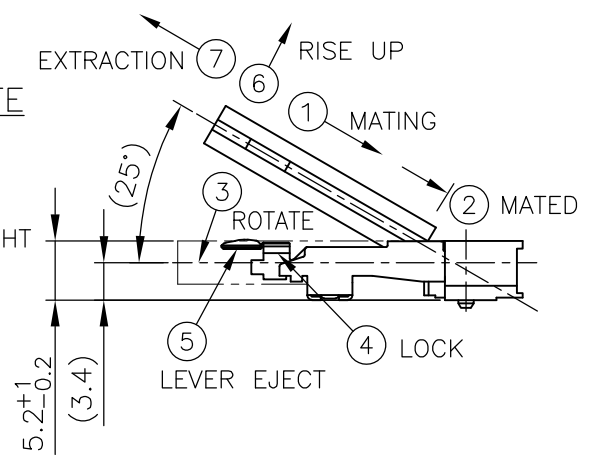

- (APPLIED TO SHEET 1-2)
- MATERIAL ; HOUSING: HIGH TEMPERATURE THERMO PLASTIC UL94V-0
 CONTACT: COPPER ARROY
 LOCK LEVER STAINLESS STEEL
 SOLDER PEG: COPPER ARROY
 - FINISH ; CONTACT AREA: GOLD FLASH ON 0.0013MIN ALL OVER NICKEL.
 SOLDERING AREA: GOLD FLASH PLT.
 SOLDER PEG: TIN PLATING.
- ⚠ MECHANICAL KEY POSITION OF CONNECTOR SEE TABLE.
 - ⚠ TOLERANCES NON-CUMULATIVE.
 - ⚠ NOT TO SCALE.
 - ⚠ [] INSIDE MUST BE RESIST COAT EXCEPT SOLDER PATTERN.
7. IF THE MODULE DOESN'T INSERT AND LOCK IN THE LATCH SMOOTHLY, OPEN WIDE BOTH LATCHES BY MANUAL. AND THE MODULE MUST BE INSERTED AND LOCKED IN THE LATCH.

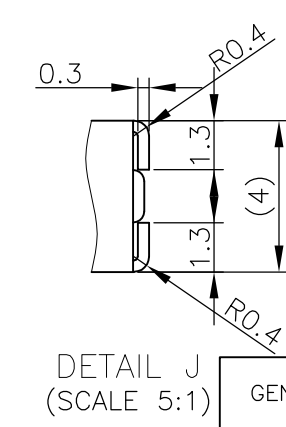
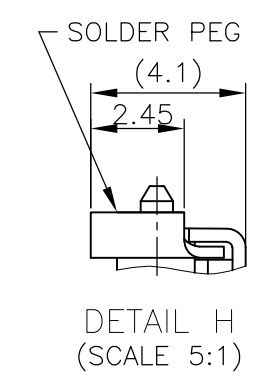
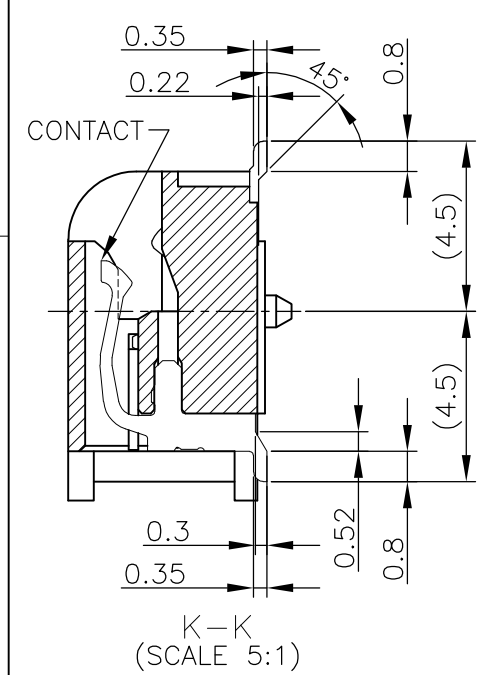

GENERAL TOLERANCE
 10 ≥ : ±0.2
 30 ≥ > 10 : ±0.25
 100 ≥ > 30 : ±0.3
 ANGLES : ±3°

TIN PLATING	AVAILABLE	1.8V (DDR2)	17.55	2.4	2.7	200	1-1473149-4
	AVAILABLE	1.8V (DDR2)	17.55	2.4	2.7	200	1473149-4
	AVAILABLE	2.5V (DDR1)	18.45	1.5	1.8	200	1473149-1
REMARK (PEG)	TOOLING STATUS	POWER SUPPLY	D5	D4	D3	POS	PART NO.
THIS DRAWING IS A CONTROLLED DOCUMENT.		DWN	T.FUMIKURA		16JAN02		
		CHK	T.KUSUHARA		17JAN02		
		APVD	I.ENOMOTO		17JAN02		
DIMENSIONS: MM		TOLERANCES UNLESS OTHERWISE SPECIFIED:		NAME			
0 PLC ±		1 PLC ±		TE Connectivity			
2 PLC ±		3 PLC ±		DDR1 & DDR2 SODIMM SOCKET			
4 PLC ±		ANGLES ±		0.6mm PITCH 200POS			
FINISH		MATERIAL		STANDARD PROFILE STANDARD TYPE (NEW LATCH TYPE)			
				SIZE		CAGE CODE	DRAWING NO
				A3		00779	C-1473149
		WEIGHT		RESTRICTED TO			
		4.7g					
CUSTOMER DRAWING			SCALE	SHEET		REV	
			2:1	1 OF 4		K3	

THIS DRAWING IS UNPUBLISHED. RELEASED FOR PUBLICATION OCT. 2001.
 © COPYRIGHT 2001 By - ALL RIGHTS RESERVED.

LOC	DIST	REVISIONS			
P	LTR	DESCRIPTION	DATE	DWN	APVD
J	/	SEE SHEET 1	-	-	-

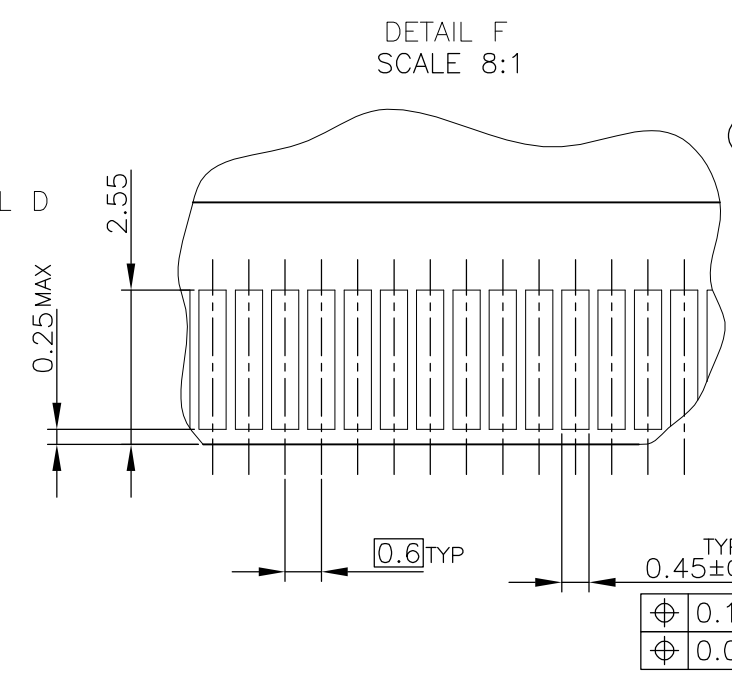
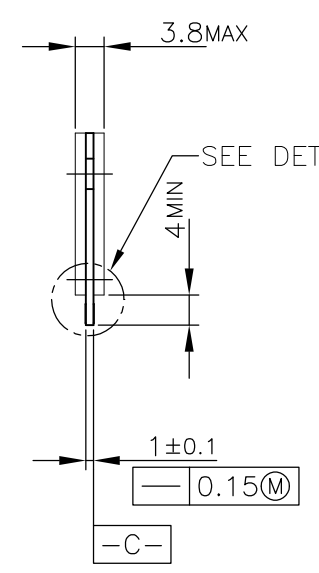
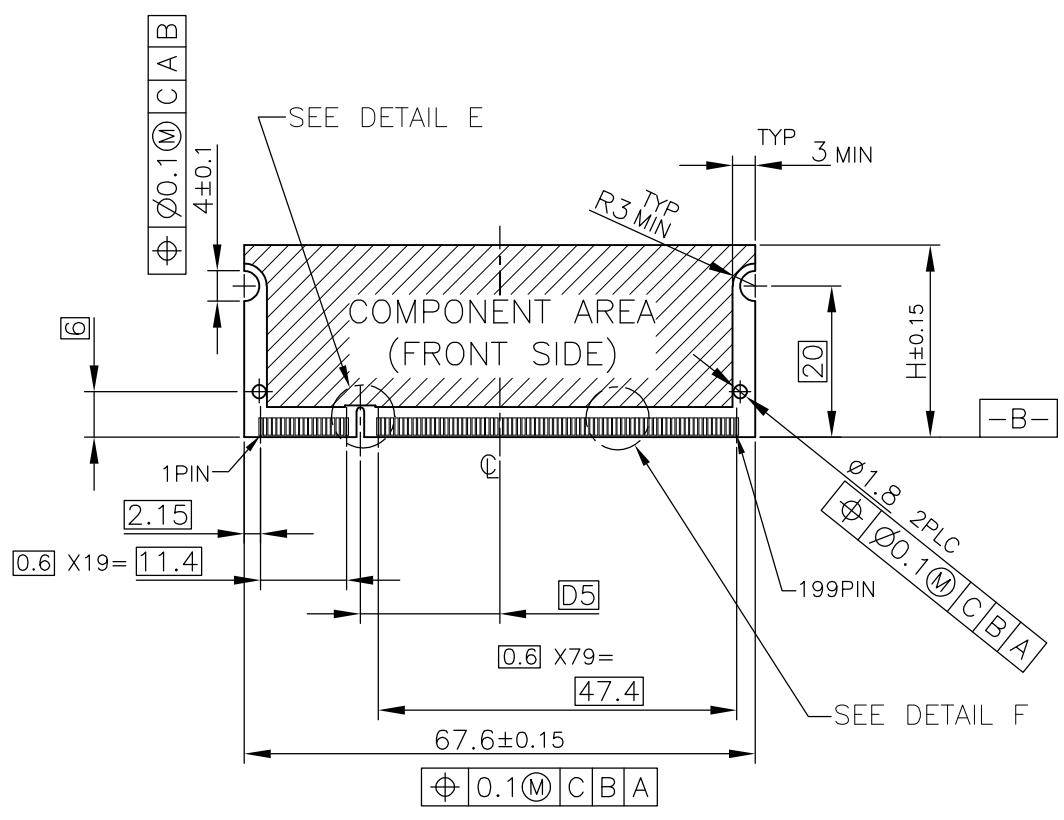

- (APPLIED TO SHEET 3)
1. TOLERANCES ON ALL DIMENSIONS ±0.15 UNLESS OTHERWISE SPECIFIED.
 2. P.C. BOARD THICKNESS APPLIES ACROSS TABS AND INCLUDES PLATING AND/OR METALIZATION.
 3. FINISH OF PAD : GOLD PLATING 0.00076 MIN. OVER Ni PLATING 0.002MIN.
- △ NO BURR
 △ CHAMFER 0.25 MAX x 45° IF EXIST.

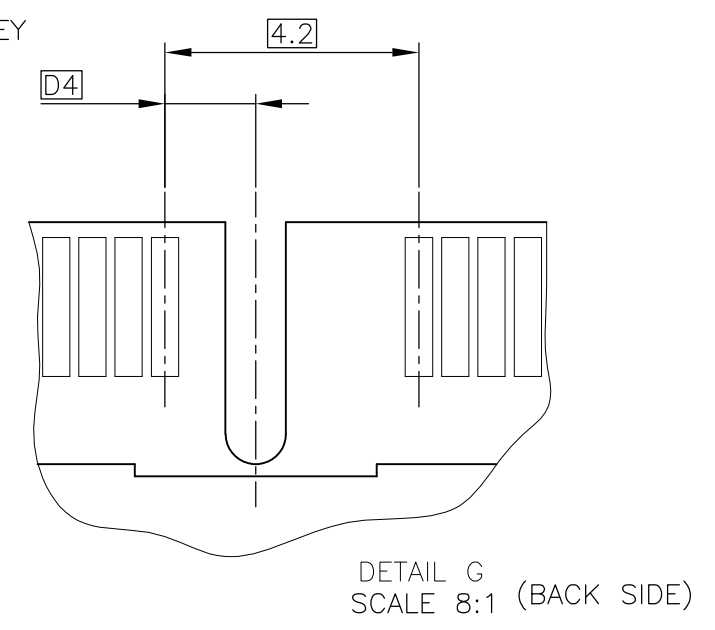
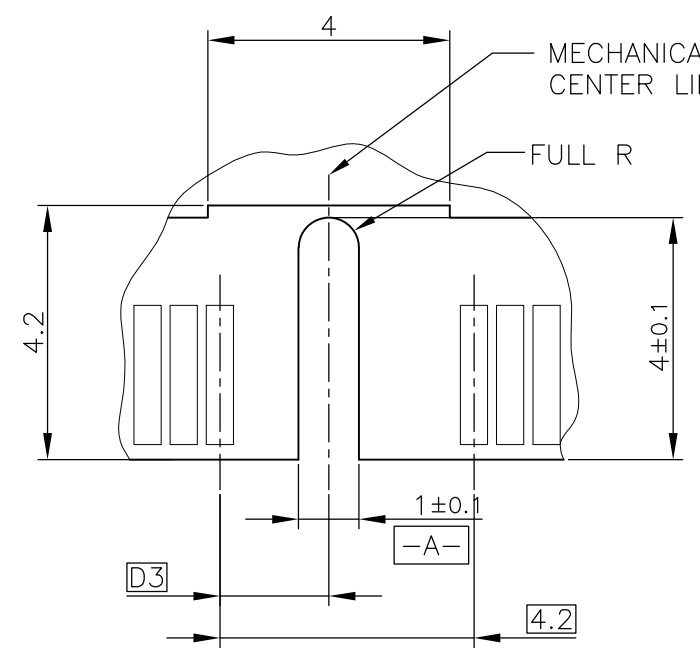
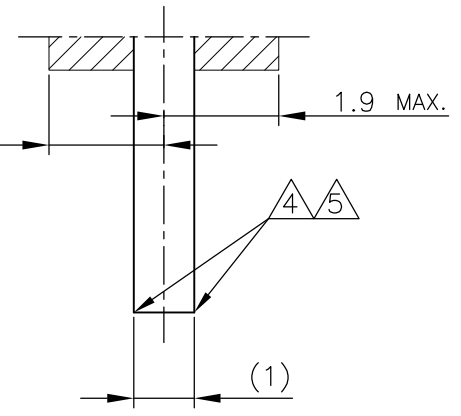
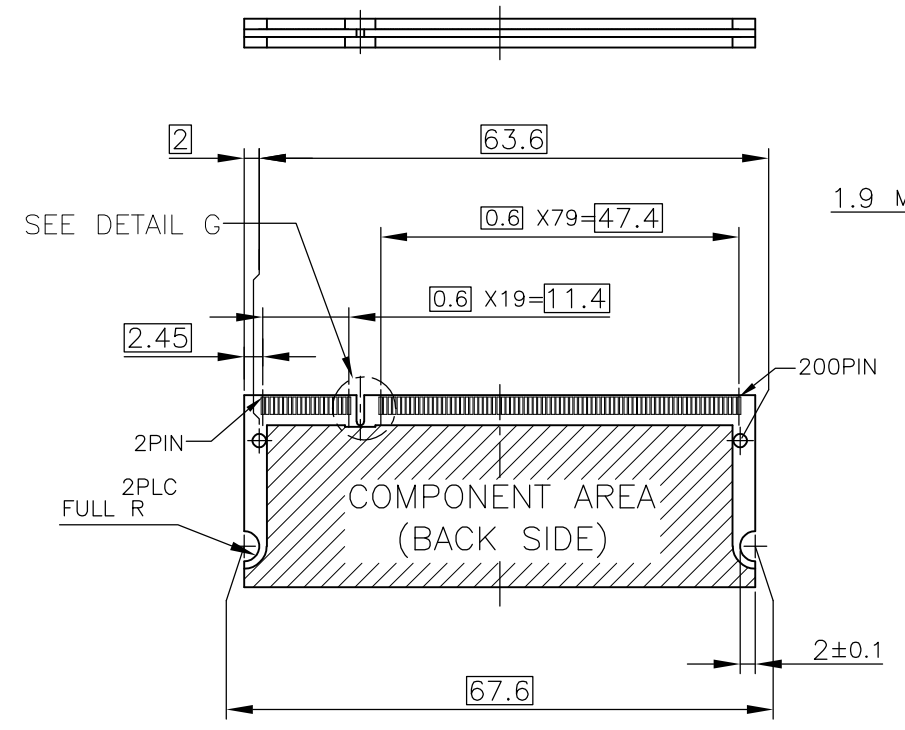

RECOMMENDED MATING P.C.B CONFIGURATION

THIS DRAWING IS A CONTROLLED DOCUMENT.		DWN	TE Connectivity NAME DDR1 & DDR2 SODIMM SOCKET 0.6mm PITCH 200POS STANDARD PROFILE STANDARD TYPE (NEW LATCH TYPE)			
DIMENSIONS: MM		CHK				
TOLERANCES UNLESS OTHERWISE SPECIFIED:		APVD				
0 PLC ± 1 PLC ± 2 PLC ± 3 PLC ± 4 PLC ± ANGLES ± FINISH ±		PRODUCT SPEC				
MATERIAL		APPL. SPEC	SIZE	CAGE CODE	DRAWING NO	RESTRICTED TO
		WEIGHT	A300779		C-1473149	
		CUSTOMER DRAWING	SCALE	2:1	SHEET	3 OF 4
					REV	K3

THIS DRAWING IS UNPUBLISHED. RELEASED FOR PUBLICATION OCT , 2001.
 © COPYRIGHT 2001 By - ALL RIGHTS RESERVED.

LOC	DIST	REVISIONS			
P	LTR	DESCRIPTION	DATE	DWN	APVD
J	/	SEE SHEET 1	-	-	-

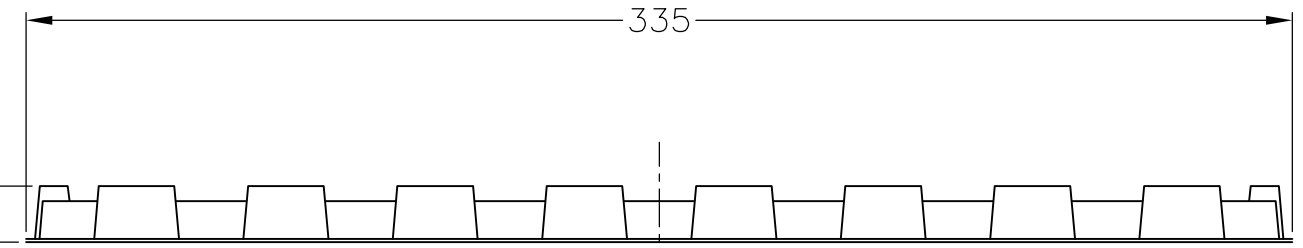
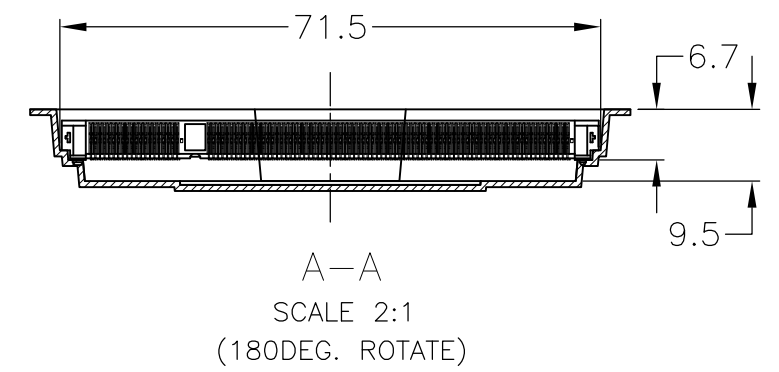
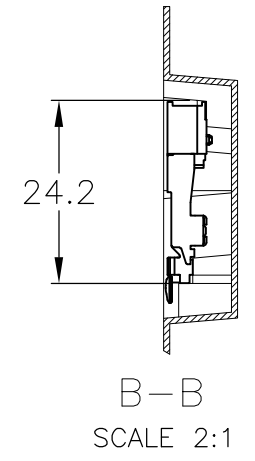
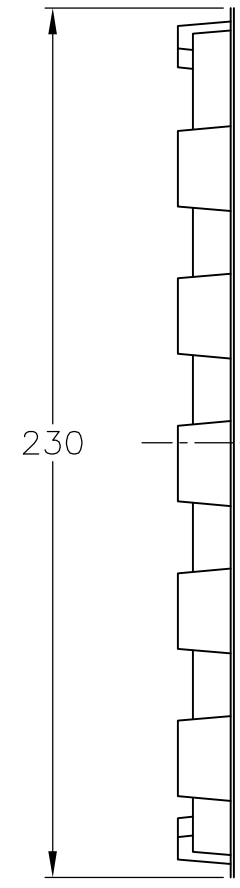
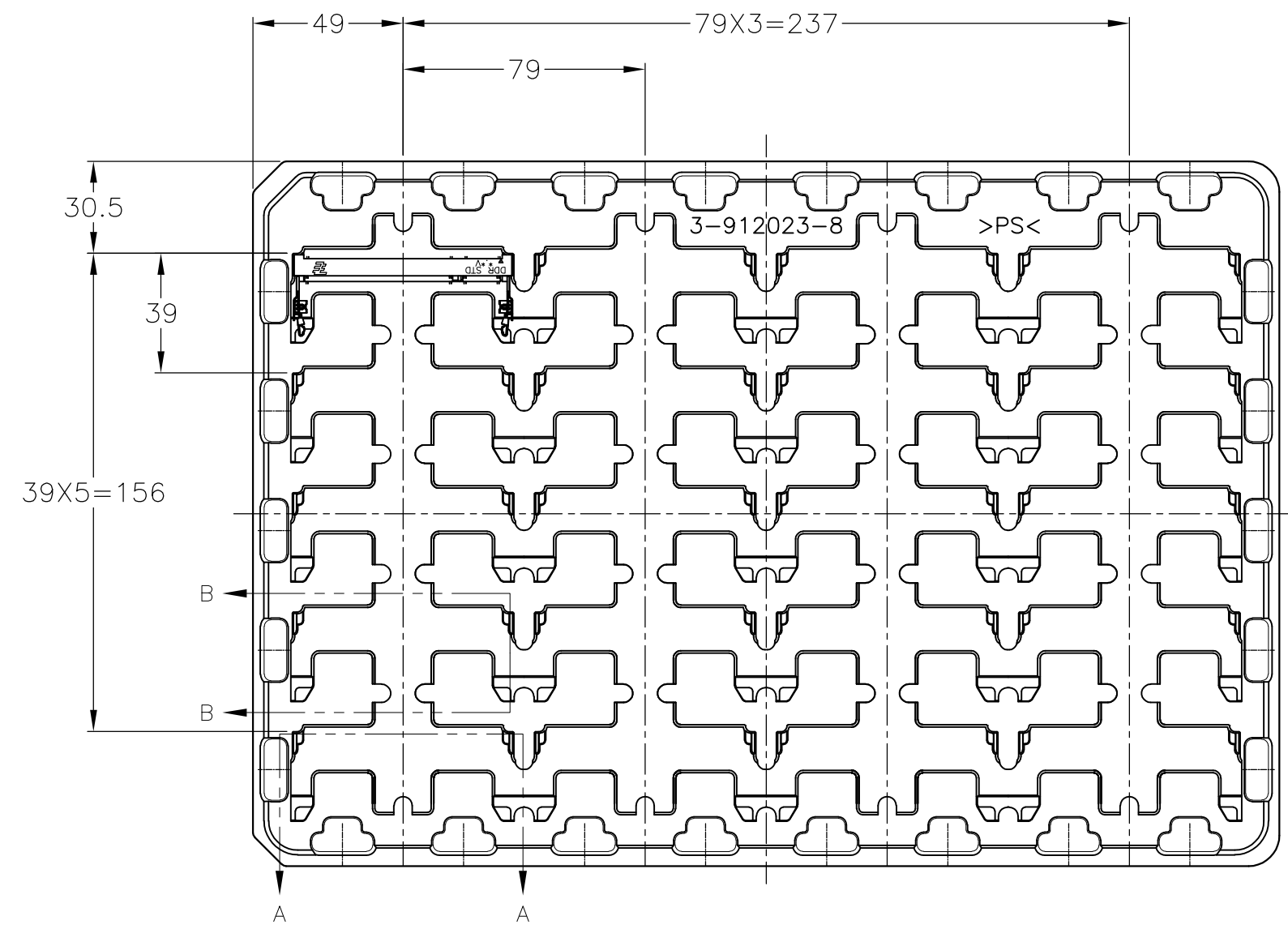

DDR2	20EA/TRAY	1-1473149-4
DDR2	20EA/TRAY	1473149-4
DDR1	20EA/TRAY	1473149-1
REMARK	QTY	P/N

14.8

- (APPLIED TO SHEET 4)
- 1 THE DIRECTION OF EACH CONNECTOR ON A TRAY IS REFERRED TO THIS DRAWING.
 - 2 GENERAL TOLERANCE: ±0.5

THIS DRAWING IS A CONTROLLED DOCUMENT.		DWN	TE Connectivity NAME DDR1 & DDR2 SODIMM SOCKET 0.6mm PITCH 200POS STANDARD PROFILE STANDARD TYPE (NEW LATCH TYPE)			
DIMENSIONS: MM		CHK				
TOLERANCES UNLESS OTHERWISE SPECIFIED:		APVD				
0 PLC ± 1 PLC ± 2 PLC ± 3 PLC ± 4 PLC ± ANGLES ± FINISH ±		PRODUCT SPEC				
MATERIAL		APPLIC. SPEC	SIZE	CAGE CODE	DRAWING NO	RESTRICTED TO
		WEIGHT	A300779 C-1473149			
		CUSTOMER DRAWING	SCALE 1:2	SHEET 4 OF 4	REV K3	