

LOC	REV	DATE	DESCRIPTION	BY	CHK	APPV
1	00					
	O	10AUG2004	RELEASED PER EC 0K01-126-04	DJH	JMR	
	A	10SEP2004	REVISED PER EC 0K40-0296-04	DLD	LLV	
	B	09MAY2006	REVISED PER ECR 06-009631	DLD	LLV	

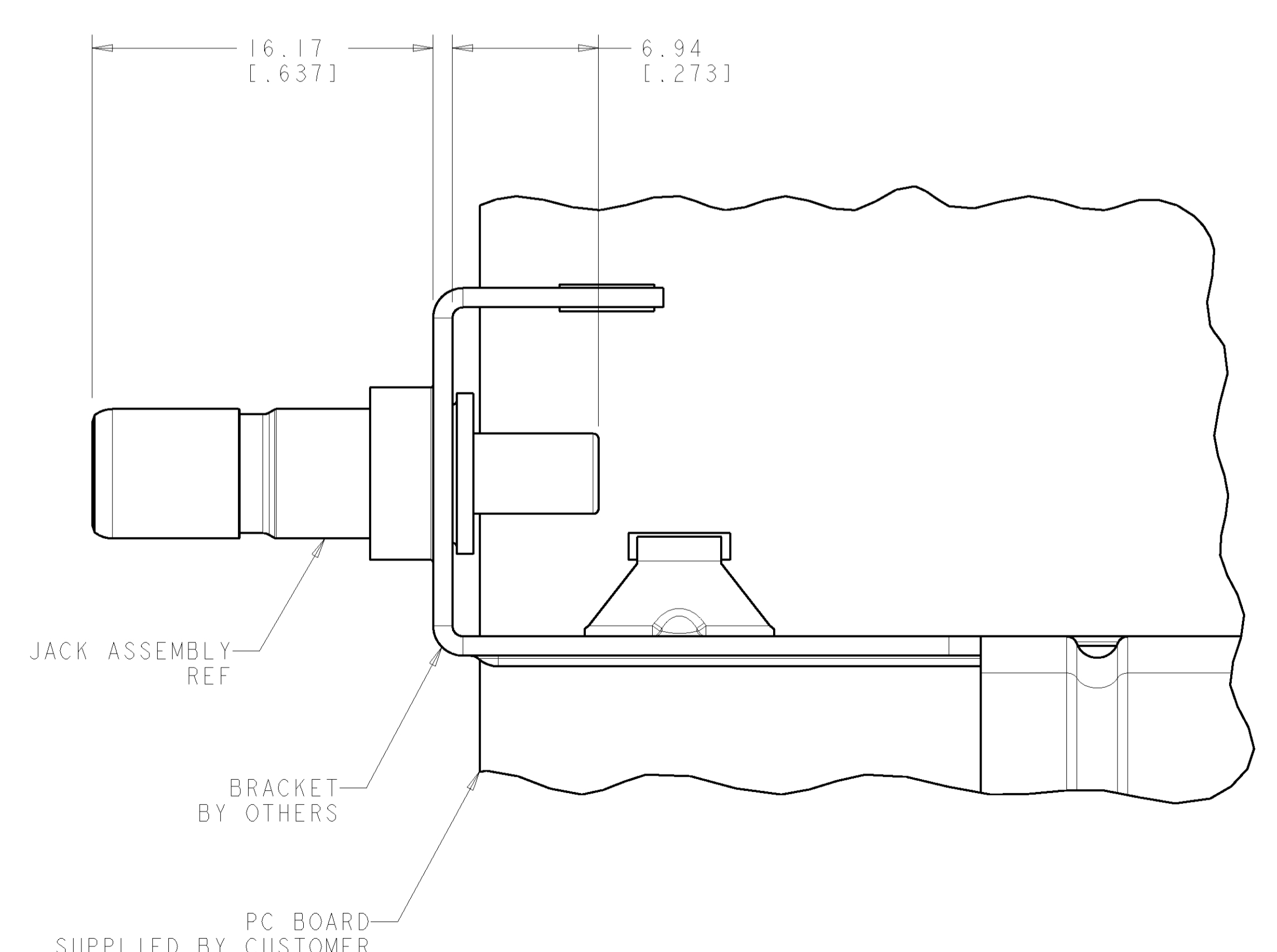
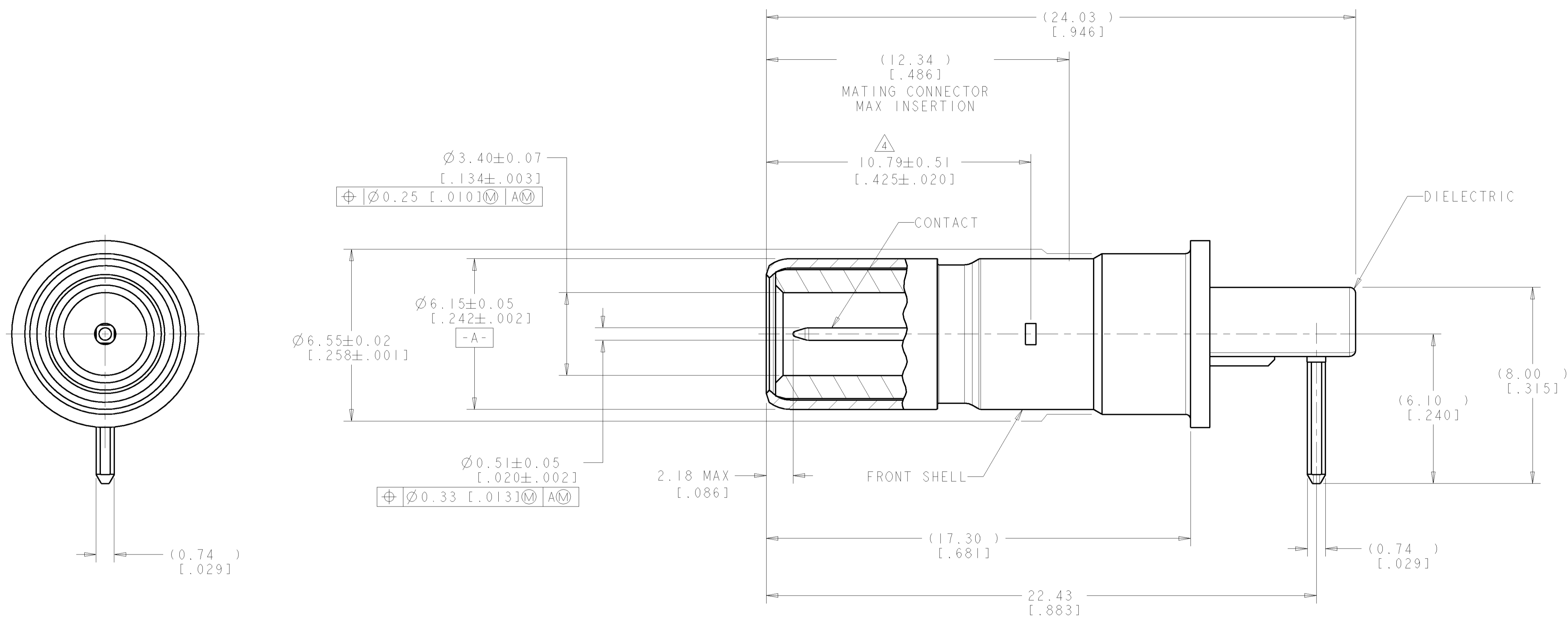

ASSEMBLED VIEW  
 SCALE 5:1  
 FOR REFERENCE ONLY

- 1 FRONT SHELL AND CONTACT: BRASS.  
 DIELECTRIC: POLYMETHYLPENTENE, NATURAL.
- 2 FRONT SHELL: 2.54µm [.000100] MIN TIN OVER 1.27µm [.000050] MIN NICKEL.  
 CONTACT: 3.81µm [.000150] MIN TIN OVER 1.27µm [.000050] MIN NICKEL.
- 3. SEE INSTRUCTION SHEET 408-8935.
- 4 STAKED IN 4 PLACES, EQUALLY SPACED AROUND CIRCUMFERENCE.  
 LOCATED APPROXIMATELY AS SHOWN.

DESCRIPTION	PART NUMBER
WITH STAKES	1488821-2
NO STAKES	1488821-1

DIMENSIONS: [mm] INCHES		TOLERANCES UNLESS OTHERWISE SPECIFIED: 0 PLC ± 1 PLC ± 2 PLC ±0.13 [.005] 3 PLC ± 4 PLC ± ANGLES ±		DWN: D.J.HARDY 21AUG2003 CHK: J.M.MYER 10SEP2003 APPV: J.M.MYER 10SEP2003		tyco Electronics Tyco Electronics Harrisburg, PA 17105-3608	
MATERIAL: $\text{A}$		FINISH: $\text{A}$		PRODUCT SPEC:		NAME: JACK ASSEMBLY, PC BOARD, LOW PROFILE, SNAP-LOCK	
APPLICATION SPEC:		WEIGHT:		SIZE: A CASE CODE: 00779 DRAWING NO: 114-13126		RESTRICTED TO:	
CUSTOMER DRAWING		SCALE: 10:1		SHEET: 1 OF 2		REV: B	

LOC	QTY	REV	DATE	BY	APPV
1N	00				

AM/FM CONNECTOR PERFORMANCE REQUIREMENTS TEST CRITERIA AND PARAMETERS MECHANICAL REQUIREMENTS		
TEST PARAMETER	SPECIFICATION	ACCEPTANCE CRITERIA
TERMINAL RETENTION	SEE BELOW	HOLD 26N FOR 60 SECONDS
APPLY AXIAL FORCE OF 26N TO THE CENTER PIN OF PCB MOUNTED ASSEMBLY, HOLD FOR 60 SECONDS, RECONNECT WITH MATING HALF, NO VISUAL CHANGES IN ASSEMBLY, VERIFY PIN DEPTH PER SHEET 1		
CONNECTOR MATING	USCAR-25 CLASS 2	45N MAX
CONNECTOR UNMATING	USCAR-25 CLASS 2	45N MAX, USING LATCH
AUDIBLE FEEDBACK	HOLD METER 600mm FROM CONNECTOR	7dB MIN ABOVE AMBIENT 5dB MIN CHANGE OVER AMBIENT WHEN MOISTURE CONDITIONED

AM/FM CONNECTOR PERFORMANCE REQUIREMENTS TEST CRITERIA AND PARAMETERS ELECTRICAL REQUIREMENTS		
TEST PARAMETER	SPECIFICATION	ACCEPTANCE CRITERIA
DIELECTRIC WITHSTANDING VOLTAGE	USCAR-17	800V
ENVIRONMENTAL TEST SEQUENCE PER USCAR-20, CLASS 1 PERFORM 10 DURABILITY CYCLES BEFORE AND AFTER ENVIRONMENTAL SEQUENCING MEASURE PARAMETERS WHEN MATED, AFTER INITIAL 10 DURABILITY CYCLES, AND AFTER TEN CYCLES FOLLOWING ENVIRONMENTAL EXPOSURE MEASURE CONNECTOR RETENTION AFTER ENVIRONMENTAL EXPOSURE		
GROUND CONTACT RESISTANCE CENTER CONTACT RESISTANCE	5 mΩ MAX INITIAL; 6 mΩ MAX FINAL 24 mΩ MAX	
CAPACITANCE	EIA-368-30A	4 pF MAX (PCB)
INSULATION RESISTANCE	1 MΩ MIN	
VOLTAGE STANDING WAVE RATIO, 70-200 MHz	EIA-364-108: USING A 75Ω VECTOR NETWORK ANALYZER WITH GATING, A PROPER TRANSMISSION LINE LENGTH FOR L1 AND L2 MUST BE USED FOR ACCURATE GATING TEST PROCEDURES. THE FOLLOWING INFORMATION IS USED TO CALCULATE THE CORRECT TRANSMISSION LINE LENGTH FOR THE HP 8753. (SEE SPECIMEN FIXTURING DIAGRAM.) $L1 > (Ti + Te + 2.4Tr) * Vp / 2$ L1 IS IDENTIFIED IN THE SPECIMEN FIXTURING DIAGRAM. Ti IS THE MINIMUM GATE INCLUSION TIME. Te IS THE MINIMUM GATE EXCLUSION TIME. Tr IS THE TIME DOMAIN EFFECTIVE RISE TIME. Vp IS THE VELOCITY OF PROPOGATION IN THE SECTION. Ti IS 1.4/FS FOR A NORMAL GATE SHAPE. Te IS 2.0/FS FOR A NORMAL GATE SHAPE. FS IS THE FREQUENCY SPAN. Tr IS 0.99/FS FS IS THE (STOP FREQUENCY-START FREQUENCY). THE STOP FREQUENCY FOR A GATED MEASUREMENT IS 2.0 GHz. THIS WILL RESULT WITH A MINIMUM L1 CABLE LENGTH OF 377mm (14.83") FOR RG-62 COAX. L2 IS CALCULATED THE SAME AS L1, HOWEVER L2 CAN AND SHOULD BE MADE LONGER THAN L1, SINCE LOSS ON THIS PORTION OF TRANSMISSION LINE IS NOT AN ISSUE.  AFTER 1 PORT CALIBRATION (S <sub>11</sub> ) IS PERFORMED, THE CUT DATA IS VIEWED IN THE TIME DOMAIN. THE START GATE AND STOP GATE SHALL BE PLACED AT LEAST 1 GATE EXCLUSION TIME AWAY FROM THE CUT. THE GATED VSWR DATA CAN NOW BE VIEWED. THE VSWR DATA TO BE USED FOR THE REPORTING TO MEET THE APPLICATION REQUIREMENTS IS 70MHz TO 200MHz WITH HIGHER FREQUENCY DATA ONLY NEEDED FOR PROPER GATING ON THE MINIMUM LENGTH OF TRANSMISSION LINE.	1.2 MAX 70MHz-200MHz
CHARACTERISTIC IMPEDANCE	93 ohm	
CONNECTOR RETENTION AFTER ENVIRONMENTS	HOLD 110N MIN FOR 5 SECONDS	

DIMENSIONS: [mm] INCHES 		TOLERANCES UNLESS OTHERWISE SPECIFIED: 0 PLC ± 1 PLC ± 2 PLC ±0.13 (.005) 3 PLC ± 4 PLC ± ANGLES ±		DWN: D. J. HARDY 21AUG2003 CHK: J. M. MYER 10SEP2003 APVD: J. M. MYER 10SEP2003		<b>tyco</b> Tyco Electronics Harrisburg, PA 17105-3608	
MATERIAL: - FINISH: -		WEIGHT: - CUSTOMER DRAWING		PRODUCT SPEC: - APPLICATION SPEC: -		NAME: JACK ASSEMBLY, PC BOARD, LOW PROFILE, SNAP-LOCK SIZE: A   CAGE CODE: 00779   DRAWING NO: 1488821   RESTRICTED TO: -	
SCALE: 10:1				SHEET: 2 OF 2		REV: B	