

LOC	DIST	REVISIONS					
		P	LTH	DESCRIPTION	DATE	DWN	APVD
		3		REV PER ECO 10-010036	5-18-10	CT	KH
		A		REVISED PER ECN-22-177622	04OCT2022	FN	DC

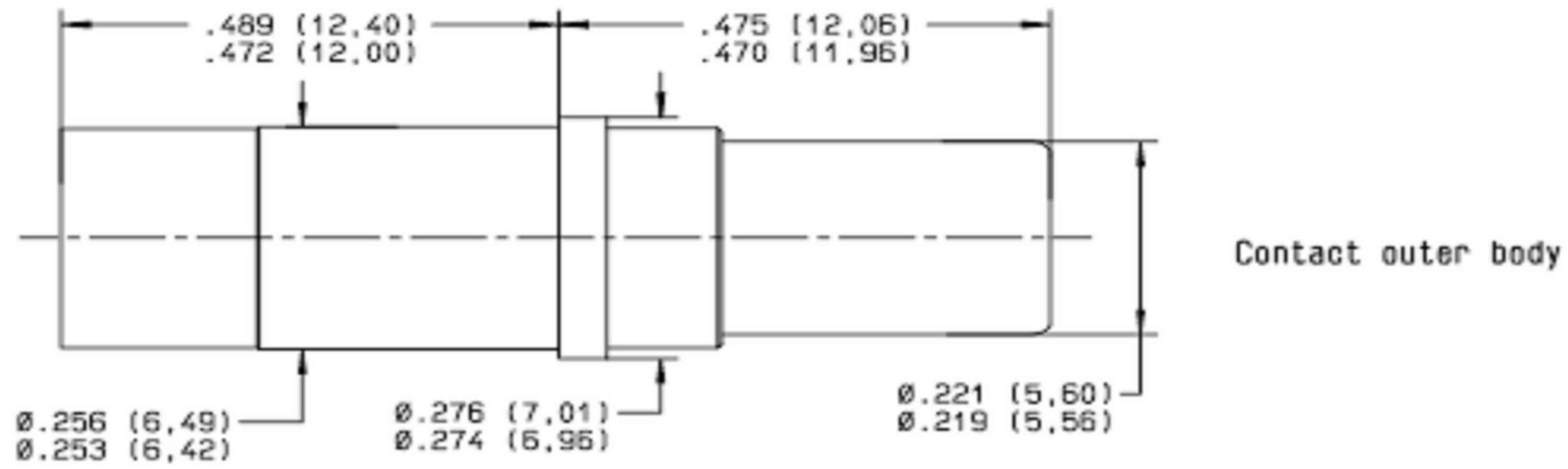

Contact outer body

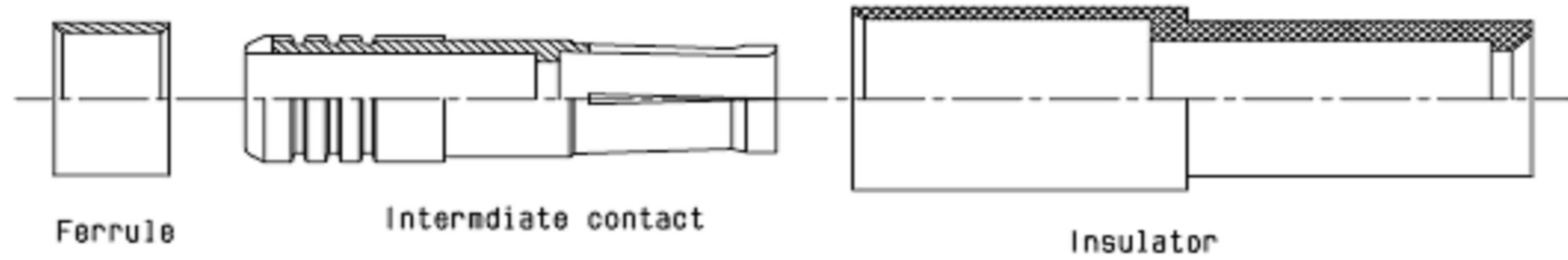

Ferrule

Intermediate contact

Insulator

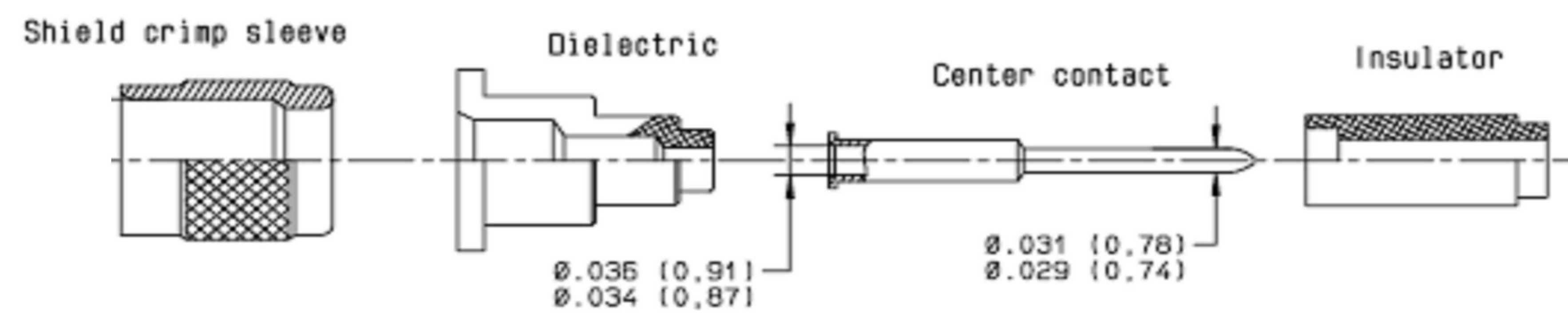

Shield crimp sleeve

Dielectric

Center contact

Insulator

Ø.036 (0.91)  
Ø.034 (0.87)

Ø.031 (0.78)  
Ø.029 (0.74)

1. MATERIAL:  
 - OUTER BODY CONTACT AND INTERMEDIATE CONTACT: BERYLLIUM COPPER 1/2 HARDNESS IN KNOOP 140 MAX (126 HV) FOR CRIMP BARREL.  
 - FERRULE AND SHIELD CRIMP SLEEVE: COPPER ALLOY.  
 - CENTER CONTACT: C97.  
 - DIELECTRIC AND INSULATORS: PTFE.
2. FINISH:  
 - ALL METALLIC PARTS: GOLD PER MIL-G-45204 TYPE I OR II GRADE C OR D CLASS 1, 50 MICROINCHES OVER NICKEL PLATE PER QQ-N-290.
3. CRIMPING TOOLS: (CRIMPED CONTACTS WILL SHOW NO CRACK WHEN INSPECTED, PER MIL-C-22520, AT 10x)  
 - CENTER CONTACT:  
 BASIC TOOL: M22520/2-01 (REF TE P/N 601966-1)  
 SELECTOR SET 3  
 POSITIONER (REF TE P/N 1738338-1)  
 - INTERMEDIATE AND OUTER BODY CONTACTS:  
 BASIC TOOL: M22520/5-01 (REF TE P/N 608650-1)  
 DIE: M22520/5-05 (REF TE P/N 1738336-1)  
 DIE CLOSURE: B FOR INTERMEDIATE CONTACT.  
 A FOR OUTER BODY CONTACT.
4. EXTRACTION TOOL: M81969/28-01 (REF TE P/N 91074-1)
5. APPLICABLE CABLES: PAN 6421, M17/176-0002, RAYCHEM 10613
6. APPLICABLE CABLE: RAYCHEM 10614
7. THIS PRODUCT IS SOLD BY TYCO ELECTRONICS UNDER A LICENSE FROM RADIALL SA.

6	1738033-2
5	1738033-1
REMARKS	PART NUMBER

<small>THIS DRAWING IS UNPUBLISHED. RELEASED FOR PUBLICATION. IT IS THE PROPERTY OF TYCO ELECTRONICS CORPORATION. IT IS TO BE CONTROLLED THROUGHOUT THE ENTIRE PRODUCT LIFE CYCLE. IT IS TO BE CONTROLLED FOR THE LATEST REVISION.</small>		DWN: R FLAIG 01FEB2010 CHK: J MOSIER 01FEB2010 APVD: J MOSIER 01FEB2010	Tyco Electronics Corporation Harrisburg, PA 17105-3608
DIMENSIONS: INCHES(mm)	TOLERANCES UNLESS OTHERWISE SPECIFIED: 0 PLC ±. 1 PLC ±. 2 PLC ±. 3 PLC ±. 4 PLC ±. ANGLES ±. FINISH ±.	NAME: CONTACT, PIN, CONCENTRIC TWINAX PRODUCT SPEC: APPLICATION SPEC:	SIZE: A1 CAGE CODE: 00779 DRAWING NO: 1738033
MATERIAL:	FINISH:	WEIGHT: -	RESTRICTED TO: -
CUSTOMER DRAWING		SCALE: N/A	SHEET 1 OF 4 REV A

### ASSEMBLY INSTRUCTIONS

LOC	DIST	REVISIONS			
P	LYN	DESCRIPTION	DATE	DWN	APVD
DF	A5	SEE SHEET 1			

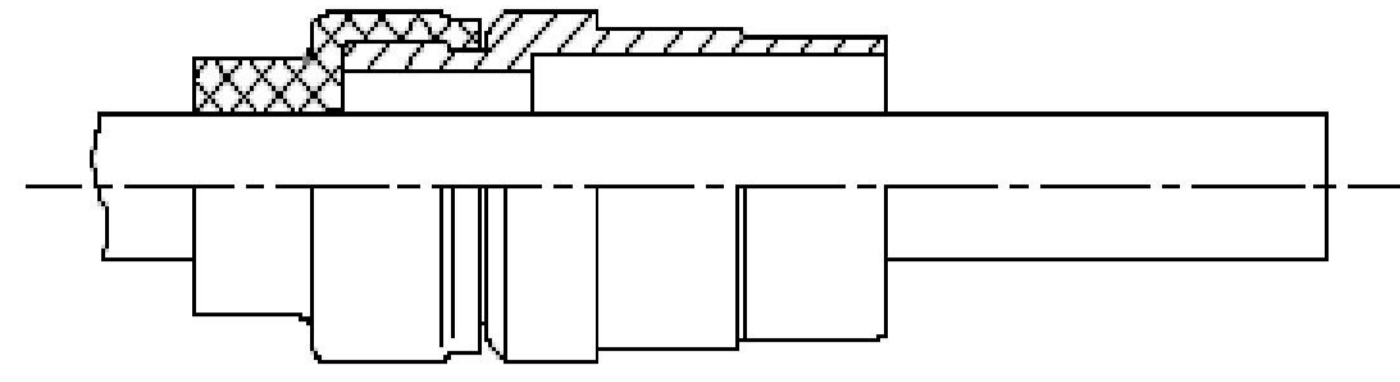

FOR ENVIRONMENTAL CONTACT, SLIDE THE ENVIRONMENTAL SLEEVE OVER THE CABLE BEFORE STRIPPING

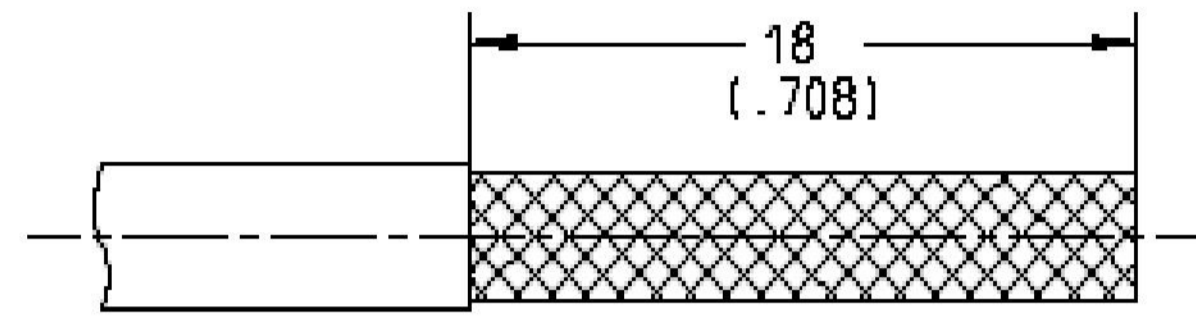

STRIP THE CABLE AS ILLUSTRATED

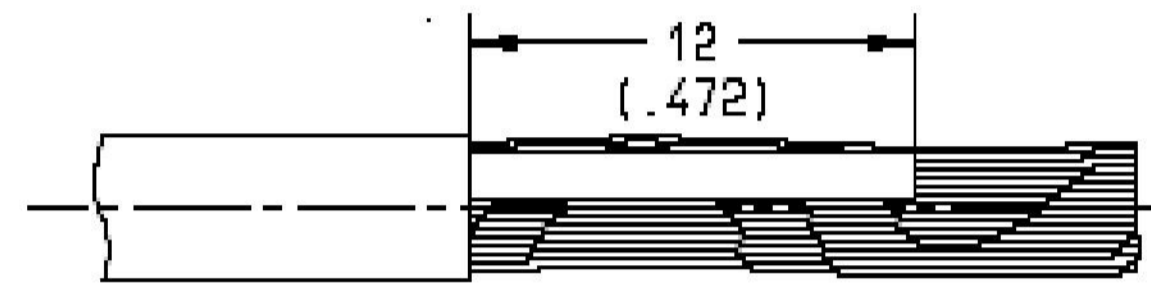

COMB BRAIDS AND CUT THE HIGH IMMUNITY RIBBON. CUT THE TWO CONDUCTORS TO LENGTH INDICATED

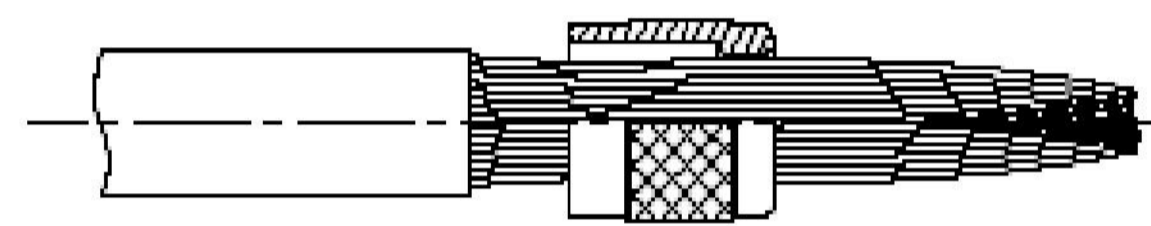

SLIDE SHIELD CRIMP SLEEVE OVER THE BRAID AGAINST THE SHEATH CUT END. FIRST, TWIST THE BRAID END TO FACILITATE THE SLIDING OF THE SHIELD CRIMP SLEEVE

1st conductor: blue (center contact)

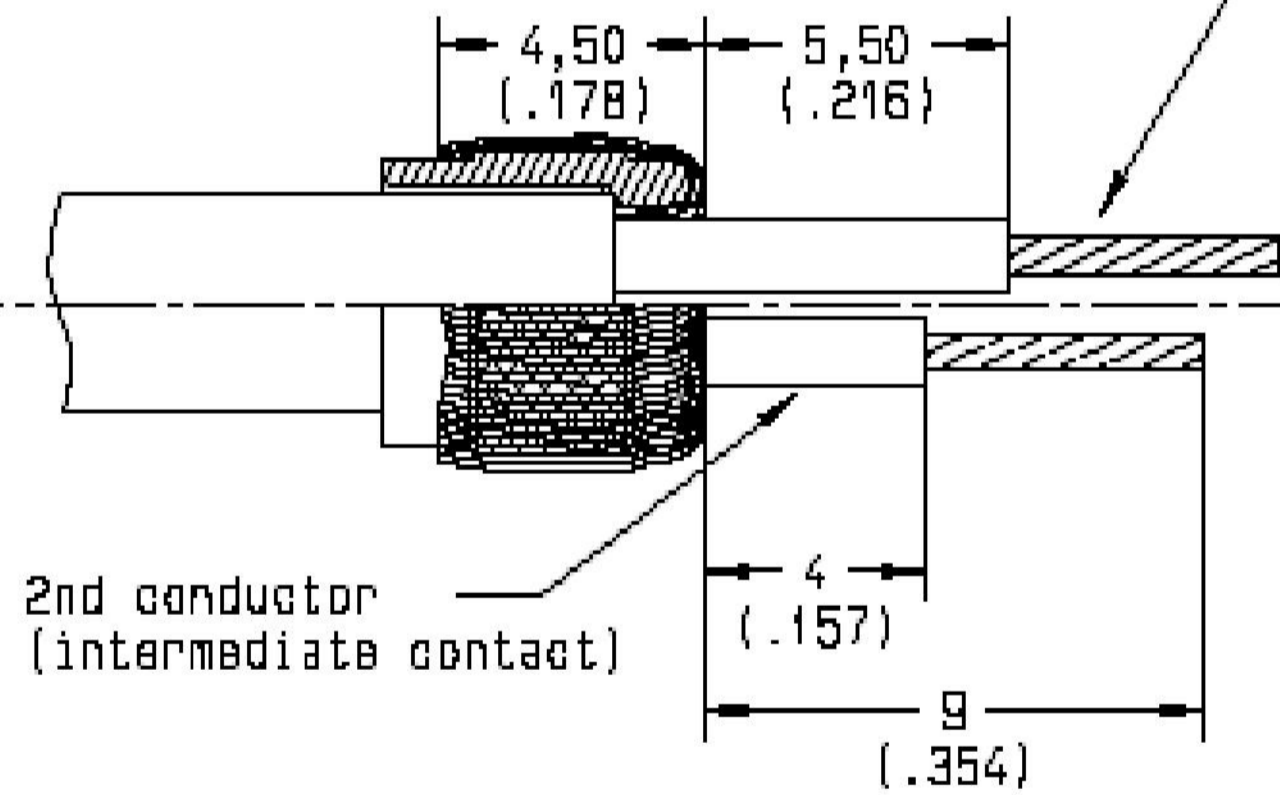

FOLD BACK THE BRAID OVER THE SHIED CRIMP SLEEVE CUT THE BRAID AND TWO CONDUCTORS AS SHOWN. CUT THE ROD FILLERS

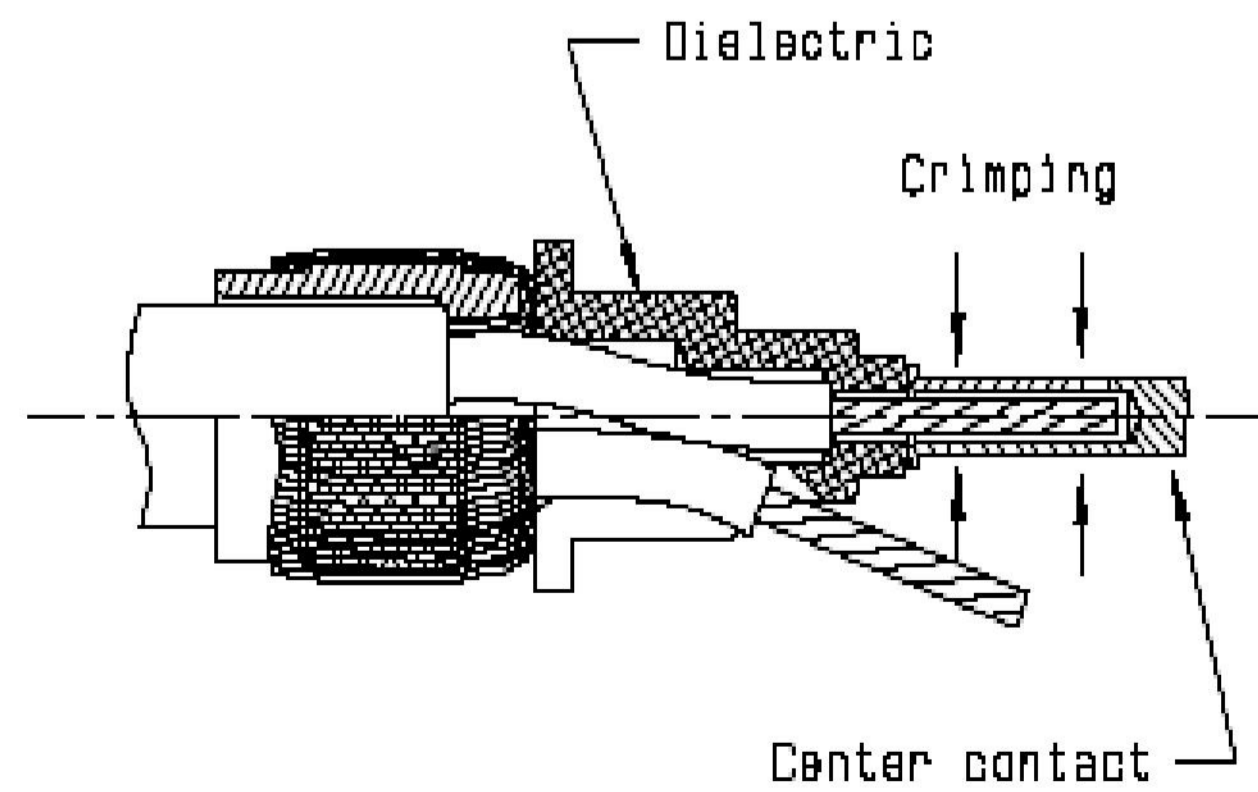

A: SLIDE THE DIELECTRIC ON THE FIRST CONDUCTOR. THE SECOND CONDUCTOR COMING IN THE SLOT.

B: SLIDE THE CENTER CONTACT ON THE FIRST CONDUCTOR UNTIL IT BUTTS AGAINST THE BRAID. THE CABLE CONDUCTOR MUST BE VISIBLE THROUGH THE INSPECTION HOLE.

C: CRIMP THE CENTER CONTACT:  
 - CRIMPING TOOL M22520/2.01 (REF TE P/N 601966-1), SELECTOR 3  
 - POSITIONER (REF TE P/N 1738338-1).

<small>THIS DRAWING IS UNPUBLISHED. RELEASED FOR PUBLICATION BY TYCO ELECTRONICS CORPORATION. ALL INTERNATIONAL RIGHTS RESERVED.</small>		DWN R FLAIG 01FEB2010 CHK J MOSIER 01FEB2010 APVD J MOSIER 01FEB2010	Tyco Electronics Corporation Harrisburg, PA 17105-3608
DIMENSIONS: INCHES(mm) 		TOLERANCES UNLESS OTHERWISE SPECIFIED: 0 PLC ± 1 PLC ± 2 PLC ± 3 PLC ± 4 PLC ± ANGLES ± FINISH ±	NAME CONTACT, PIN, CONCENTRIC TWINAX SIZE A1 CAGE CODE 00779 DRAWING NO C=1738033 RESTRICTED TO
MATERIAL		WEIGHT	SCALE N/A SHEET 2 OF 4 REV A
CUSTOMER DRAWING			

LOC		DIST		REVISIONS			
P	LTN	DESCRIPTION	DATE	OWN	APVD		
-	-	SEE SHEET 1	-	-	-		

ASSEMBLY INSTRUCTIONS (CONT'D)

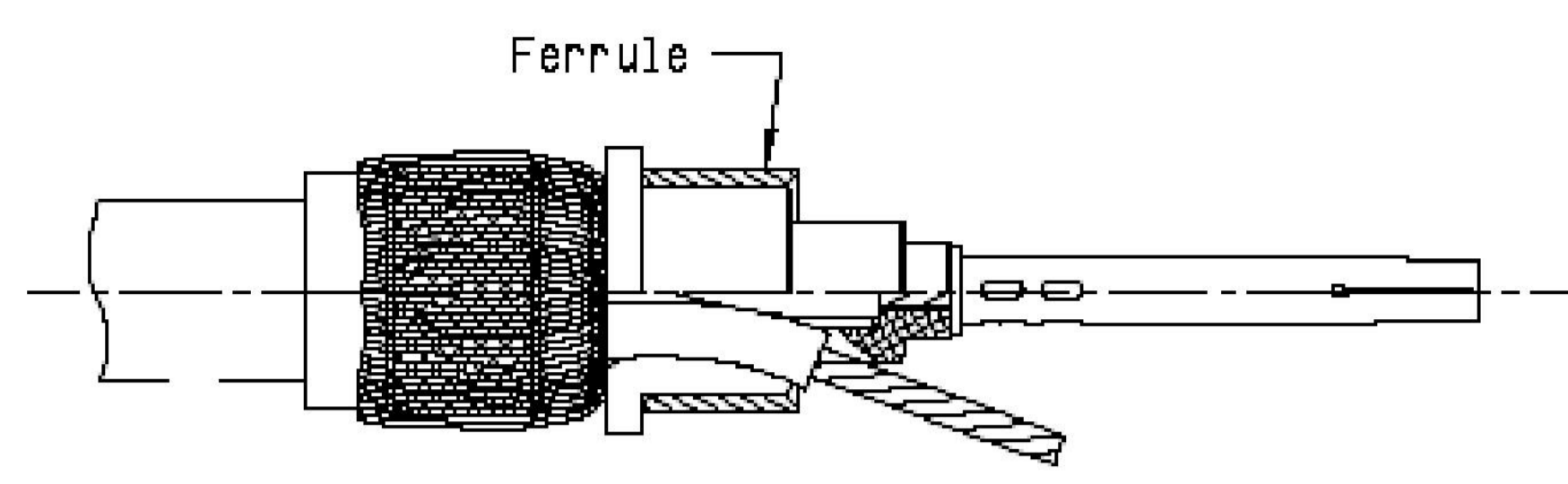

SLIDE THE FERRULE OVER THE DIELECTRIC UNTIL IT BUTTS AGAINST THE SHOULDER

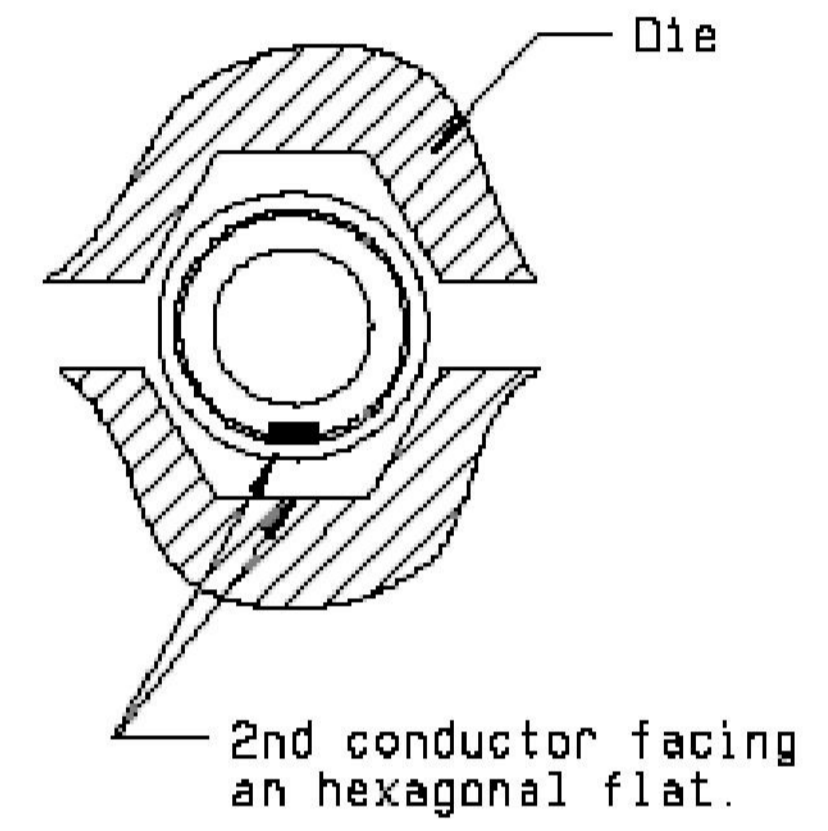
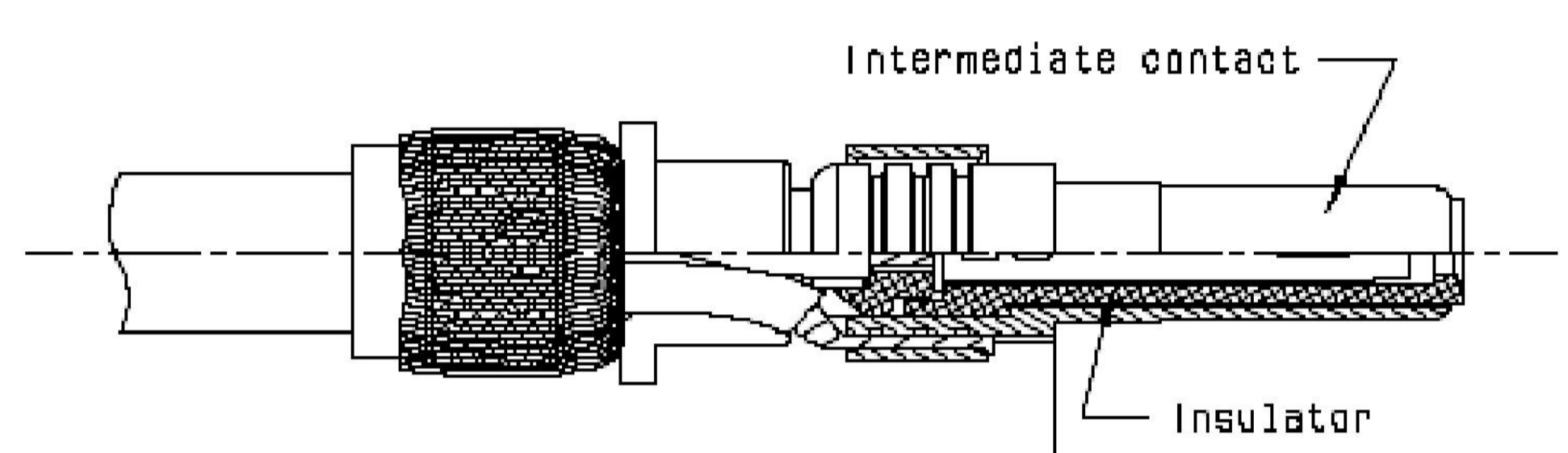

- A: SLIDE THE INTERMEDIATE INSULATOR OVER THE CRIMPED CENTER CONTACT. THEN, INTRODUCE THIS SUB-ASSEMBLY INTO THE INTERMEDIATE CONTACT
- B: PUT THE SECOND CONDUCTOR IN THE BARREL SLOT, SLIDE BACK THE FERRULE OVER THE INTERMEDIATE CONTACT BARREL (AS SHOWN)
- C: CRIMP THE FERRULE:
  - CRIMPING TOOL M22520/5.01 (REF TE P/N 608650-1)
  - DIE M22520/5.05 (REF TE P/N 1738336-1), HEX B ( 4.5 MM) .178 ON FLATS)
 BE SURE THE SECOND CONDUCTOR IS FACING AN HEXAGONAL FLAT BEFORE CRIMP

The ferrule and the 2nd conductor must not be more than flush the contact shoulder.

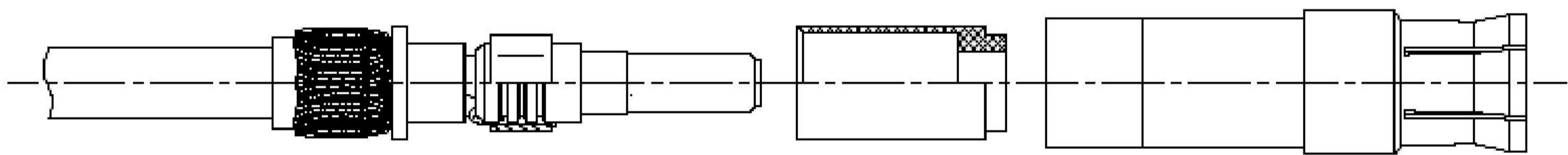

INTRODUCE THE INTERMEDIATE CONTACT INTO THE INTERMEDIATE INSULATOR, THEN INTO THE CONTACT OUTER BODY

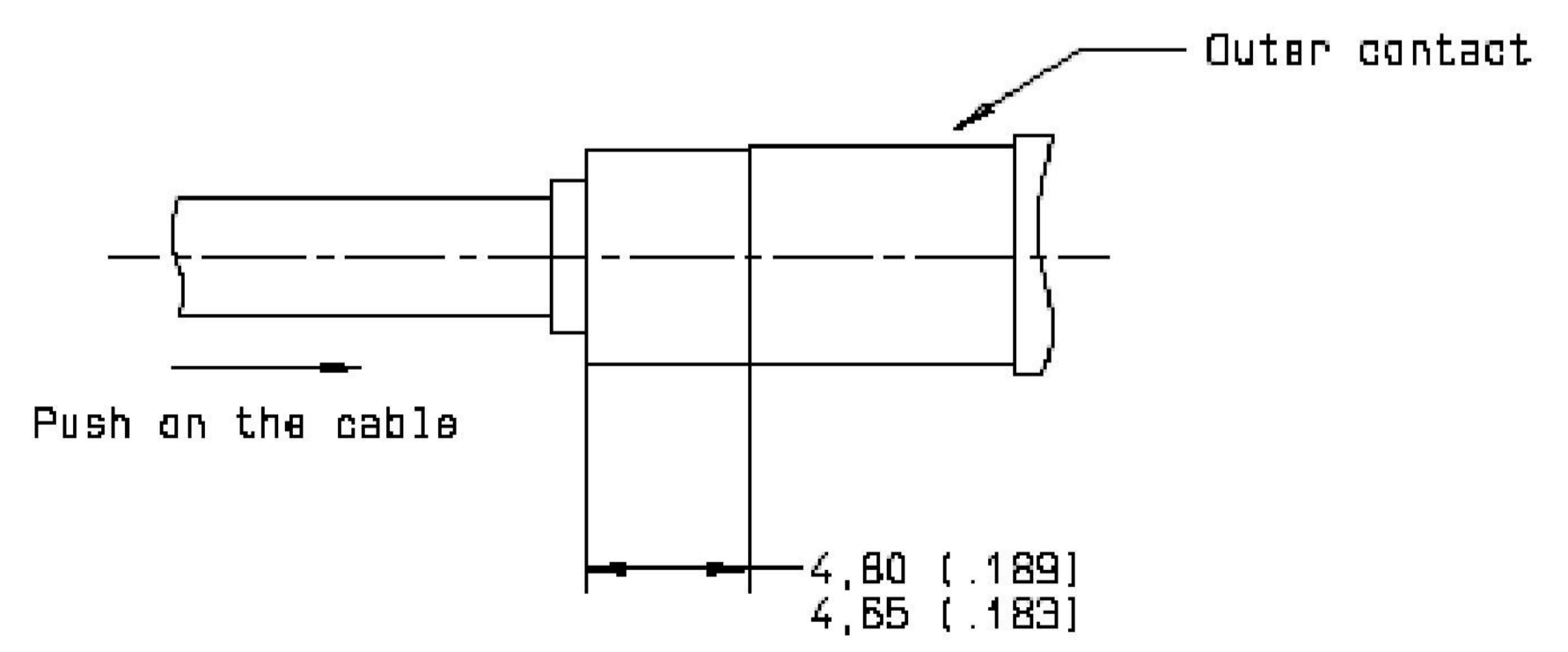

- CRIMP THE OUTER CONTACT:
  - CRIMPING TOOL M22520/5.01 (REF TE P/N 608650-1)
  - DIE M22520/5.05 (REF TE P/N 1738336-1), HEX A ( ( 5.4 MM) .213 ON FLATS)
 PRESS LIGHTLY THE OUTER CONTACT BETWEEN DIES, IN THE INDICATED CRIMPING AREA (AS SHOWN) AND PUSH ON THE CABLE TO PUT ALL COMPONENTS IN A GOOD POSITION. THEN CLOSE THE DIES COMPLETELY.

FOR ENVIRONMENTAL CONTACT, BRING BACK THE ENVIRONMENTAL SLEEVE ON THE CONTACT OUTER BODY

<small>THIS DRAWING IS A CONTROLLED DOCUMENT FOR TYCO ELECTRONICS CORPORATION. IT IS SUBJECT TO CHANGE WITHOUT NOTICE AND WITHOUT OBLIGATION. SHOULD BE CONTROLLED FOR THE LATEST REVISION.</small>		DWN R FLAIG 01FEB2010 CHK J MOSIER 01FEB2010 APVD J MOSIER 01FEB2010	Tyco Electronics Corporation Harrisburg, PA 17105-3608
DIMENSIONS: INCHES(mm) 		TOLERANCES UNLESS OTHERWISE SPECIFIED: 0 PLC ± 1 PLC ± 2 PLC ± 3 PLC ± 4 PLC ± ANGLES ± FINISH ±	NAME CONTACT, PIN, CONCENTRIC TWINAX PRODUCT SPEC APPLICATION SPEC SIZE CAGE CODE DRAWING NO RESTRICTED TO
MATERIAL:		WEIGHT:	A100779C=1738033 SCALE N/A SHEET 3 OF 4 REV A
CUSTOMER DRAWING		CUSTOMER DRAWING	

THIS DRAWING IS UNPUBLISHED. RELEASED FOR PUBLICATION 20  
 COPYRIGHT 2002 BY TYCO ELECTRONICS CORPORATION. ALL INTERNATIONAL RIGHTS RESERVED.

LOC		DIST		REVISIONS			
P	LTN	DESCRIPTION	DATE	DWN	APVD		
-	-	SEE SHEET 1	-	-	-		

- INSPECTION DIMENSIONS AFTER ASSEMBLY -

PIN TWINAX CONTACT:

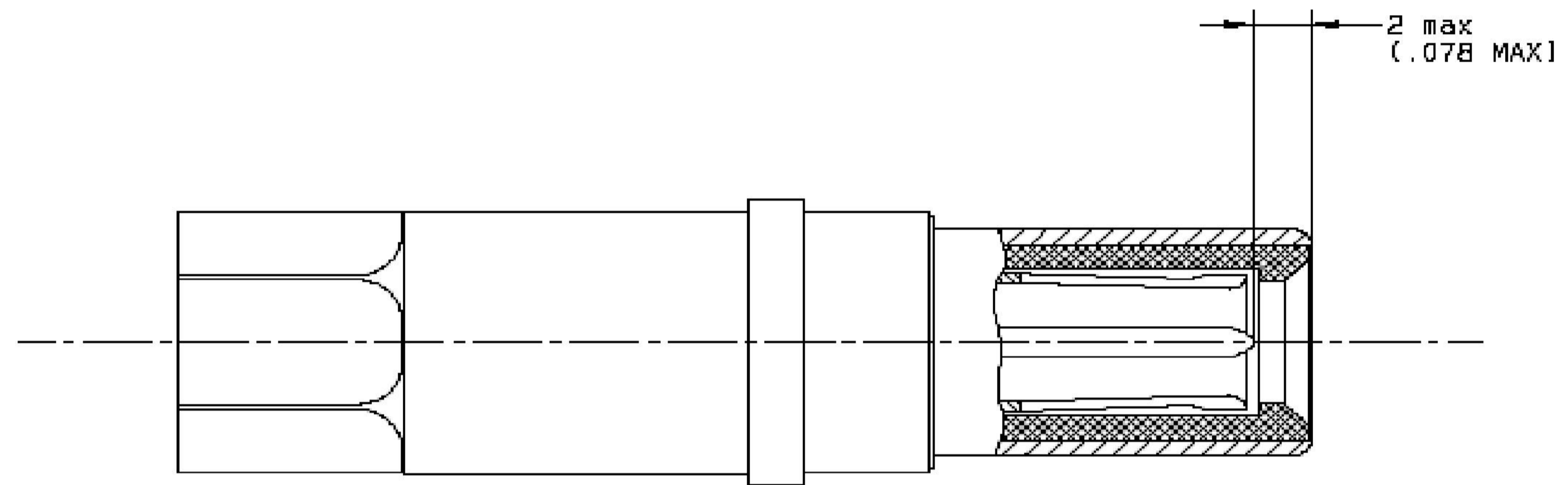

SOCKET TWINAX CONTACT:

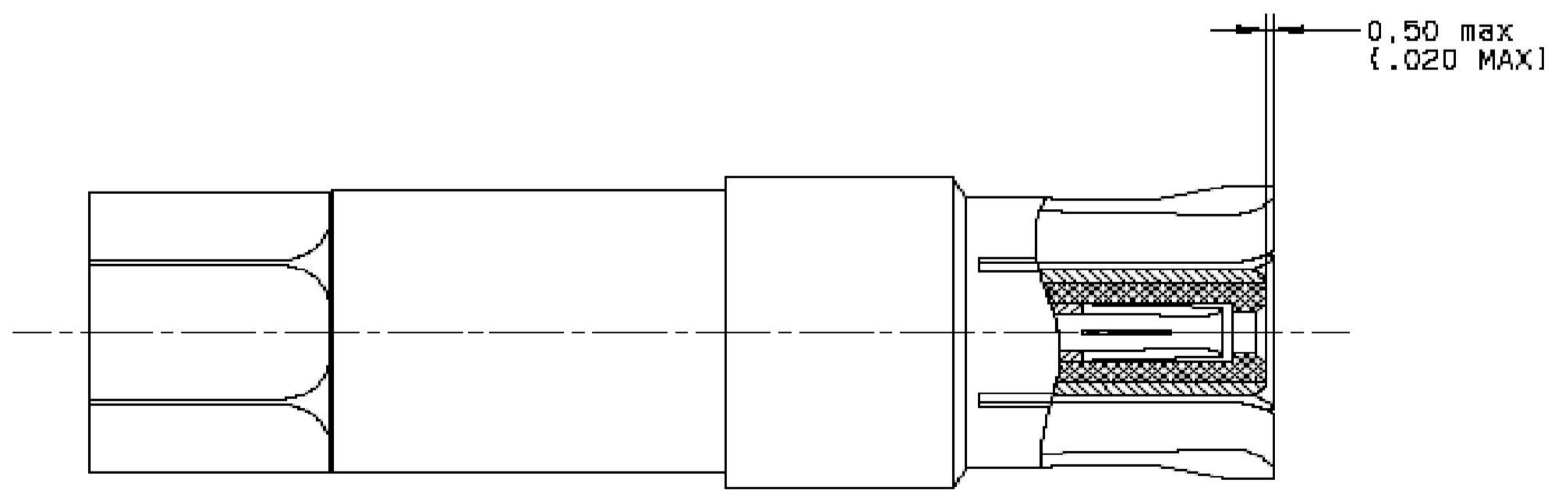

<small>THIS DRAWING IS UNPUBLISHED DOCUMENT FOR TYCO ELECTRONICS CORPORATION. IT IS THE PROPERTY OF COMPANY AND SHOULD BE CONTROLLED AND DISTRIBUTION SHOULD BE CONTROLLED FOR THE LATEST REVISION.</small>		DWN R FLAIG 01FEB2010 CHK J MOSIER 01FEB2010 APVD J MOSIER 01FEB2010	Tyco Electronics Corporation Harrisburg, PA 17105-3608
DIMENSIONS: INCHES(mm) 		TOLERANCES UNLESS OTHERWISE SPECIFIED: 0 PLC ± 1 PLC ± 2 PLC ± 3 PLC ± 4 PLC ± ANGLES ± FINISH ±	NAME CONTACT, PIN, CONCENTRIC TWINAX SIZE A100779 CAGE CODE C=1738033 DRAWING NO. 1738033 RESTRICTED TO
MATERIAL -		WEIGHT -	SCALE N/A SHEET 4 OF 4 REV A
CUSTOMER DRAWING			