

REVISIONS					
P	LTR	DESCRIPTION	DATE	DWN	APVD
D		REV PER ECO 19-016079	12-11-19	CT	DM

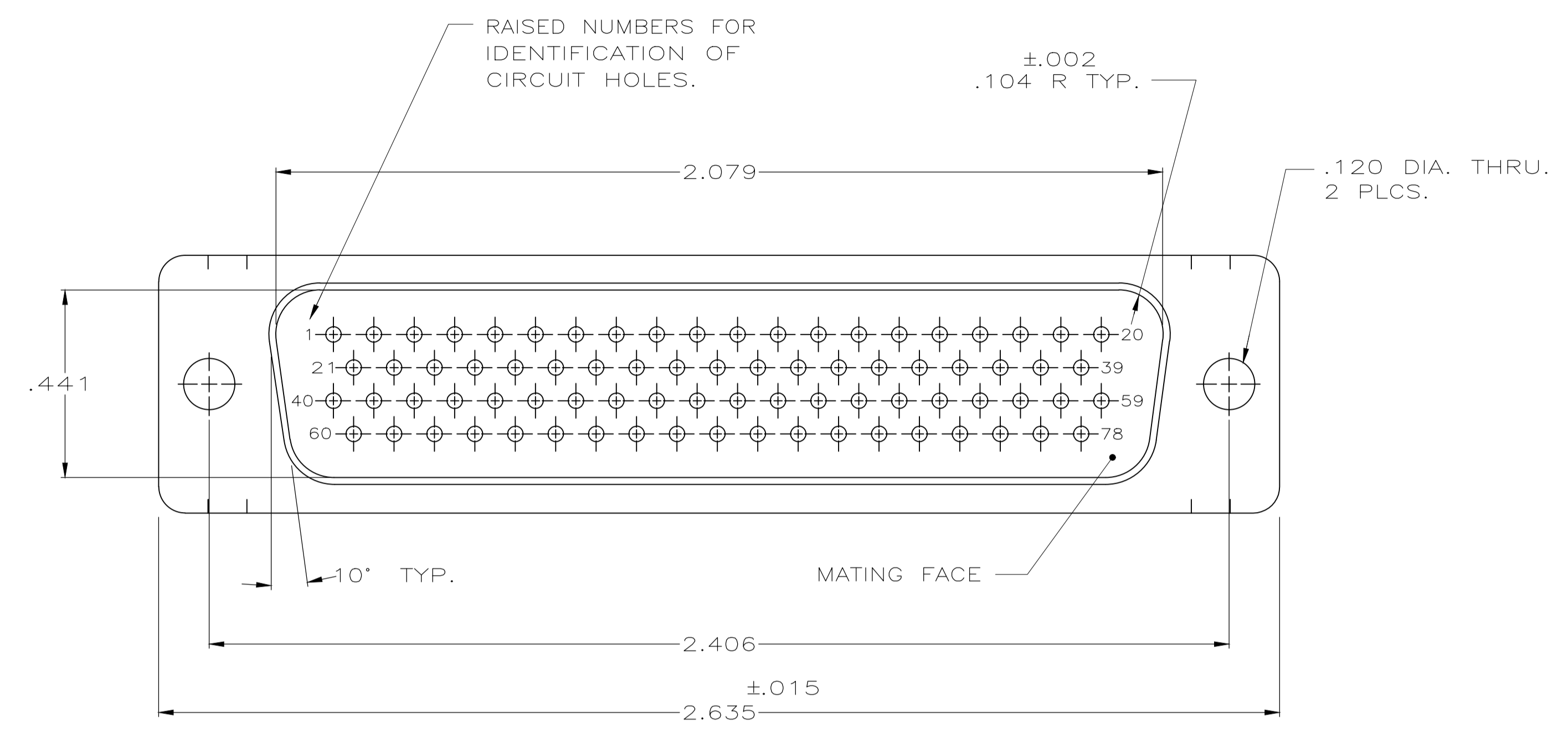

1. THIS PLUG WILL MATE WITH ANY SIZE 5,78 POSN.. RCPT. IN AMPLIMITE SERIES.
2. CONNECTOR SUPPLIED WITHOUT CONTACTS; SHOWN FOR ILLUSTRATION ONLY.
3. BE-CU RETENTION CLIPS ARE INCLUDED IN INSERTS AND INSTALLED WITH TINES POINTING TOWARDS MATING FACE.
4. OVERALL DIMENSIONS DO NOT INCLUDE RAISED CAVITY IDENTIFICATION.
5. MARKING FAR SIDE REFERS TO WIDE SIDE OF KEYSTONE. NEAR SIDE REFERS TO NARROW SIDE OF KEYSTONE.
6. 100% INSPECTION REQUIRED PER BOEING 1B01:
 A. VISUAL
 B. DWV
 C. IR
7. CUSTOMER REQUIRES SINGLE LOT DATE CODE.

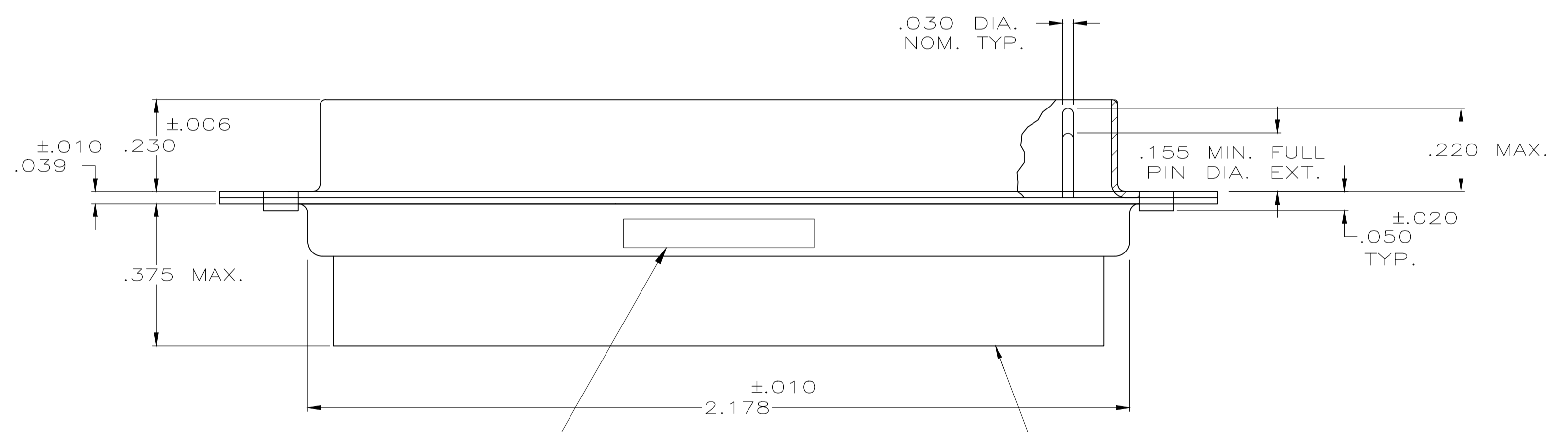

CUSTOMER P/N (IF APPLICABLE) MARKED ON FAR SIDE.
 MANUFACTURER'S NAME, BRAND NAME OR LOGO AND MANUFACTURER'S PART NO AND DATE CODE MARKED ON NEAR SIDE

INSERT ASSEMBLY
 MAT'L: DIALLYL PHTHALATE PER MIL-M-14, CLASS SDG-F
 COLOR: BLACK OR POLYPHENYLENE SULFIDE (PPS) PER MIL-M-24519, TYPE GST-40F.

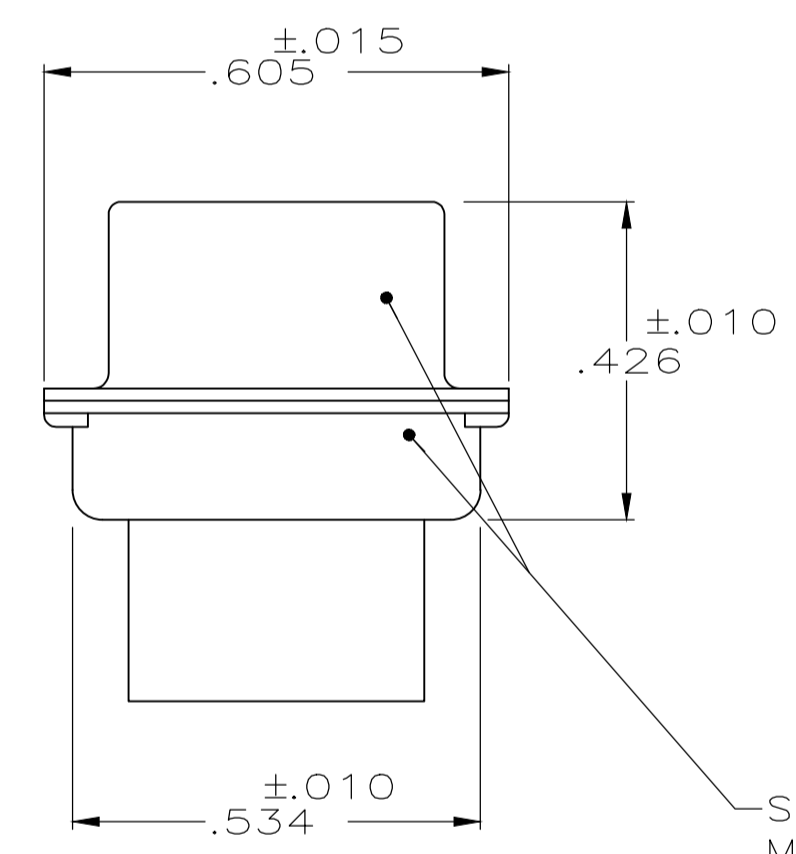

SHELL, FRONT & REAR
 MAT'L: BRASS PER ASTM B-19
 FINISH: GOLD PLATED PER ASTM-B-488 OVER 0.000100
 MIN COPPER PER AMS 2418

6	1B01 - 011PHW	1-211653-1
6	1B01 - 011	211653-1
REMARKS	CUSTOMER MARKING	PART NO.

THIS DRAWING IS A CONTROLLED DOCUMENT.		DIN 3/26/84		D. ERDMAN	
DIMENSIONS: INCHES		TOLERANCES UNLESS OTHERWISE SPECIFIED:		C/K 4-26-84	
0 PLC ± -		1 PLC ± -		B. YOHN 6-29-84	
1 PLC ± -		2 PLC ± -		APVD U. BROSCARD	
2 PLC ± -		3 PLC ± .005		NAME	
3 PLC ± -		4 PLC ± -		PRODUCT SPEC	
4 PLC ± -		ANGLES ± 0°30'		APPLICATION SPEC	
MATERIAL SEE CALLOUT		FINISH SEE CALLOUT		SIZE CAGE CODE DRAWING NO	
		WEIGHT 0.000000		A1 00779 C=211653	
		CUSTOMER DRAWING		SCALE NTS SHEET 1 OF 1 REV D	