

PART NUMBER	REVISION	DESCRIPTION	FEED TYPE
2150278-2	E	FINE CRIMP HEIGHT ADJUST	PNEUMATIC
7-2150278-2	E	PNEUMATIC AND CRIMP TOOLING KIT	PNEUMATIC
7-2150278-7	A	CRIMP TOOLING KIT	-

ATLANTIC VERSION TERMINATOR INTERFACE ADAPTER

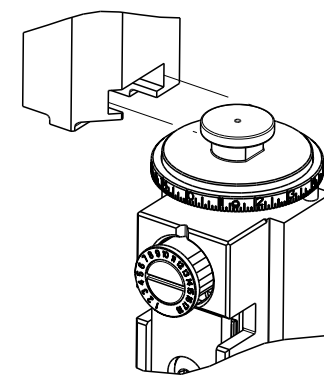

APPLICATOR DATA		
CRIMP	SIZE	TYPE
WIRE	5.11 mm [.201]	D
INSUL	-	-
APPL INSTRUCTIONS 408-35043		

TERMINAL DATA: TE TERMINAL		TE CRIMP SPECIFICATION	
TERMINAL NAME: RECPT, ULTRA-FAST FLAG, .187 SERIES			
WIRE STRIP LENGTH		INSULATION DIAMETER RANGE	
7.51-8.33 mm [.296-.328 IN]		Ø 4.19 mm MAX[.165 IN MAX]	
TERMINAL APPLICATION SPECIFICATION	114-2123		
TERMINALS APPLIED			
TE TERMINAL	TE TERMINAL	TE TERMINAL	TE TERMINAL
2-520334-2	9-520334-2	5-520336-2	
5-520334-2	2-520336-2	9-520336-2	

WIRE SIZE	CRIMP HEIGHT mm [INCH]	CRIMP HEIGHT REFERENCE SETTING	Ø SOLDER
18 OR (2) 22	1.79+/-0.05 [.070+/- .002]	5.0	.19 in [4.83mm]
22 OR 20	1.65+/-0.05 [.065+/- .002]	6.5	.19 in [4.83mm]

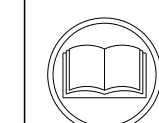

RECOMMENDED SPARE PARTS

REFER TO SUPPLIED INSTRUCTION SHEET FOR CLEANING, LUBRICATION AND STORAGE OF APPLICATOR.

TO CHECK CRIMP HEIGHT, CRIMP SOLDER (Ø.19 IN [4.83mm] 60/40 SOLID CORE) AND MEASURE AT CENTER OF SLUG.

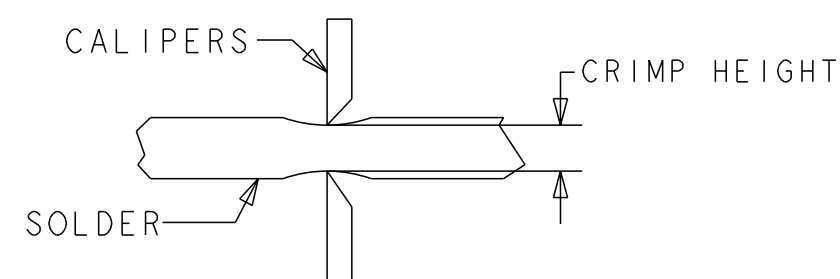

CRIMP HEIGHT REFERENCE SETTING WAS THE SETTING USED WHEN THE APPLICATOR WAS QUALIFIED AT THE FACTORY. ADJUSTMENT MAY BE NECESSARY WHEN RUNNING APPLICATOR IN THE FIELD.

TERMINAL PITCH NOT COMPATIBLE WITH MECHANICAL FEED.

6. UNLESS SPECIFIED OTHERWISE TORQUE VALUES SHALL BE USED PER DOCUMENT, 101-35000.

***WARNING**
ON INSTALLATION, SET WIRE DISC TO CRIMP HEIGHT REFERENCE SETTING FOR LARGEST WIRE SIZE. CRIMP HEIGHT REFERENCE SETTINGS GREATER THAN THE VALUE SHOWN MAY CAUSE DAMAGE TO THE CRIMP TOOLING. REFER TO THE INSTRUCTION SHEET FOR PROPER SETUP AND ADJUSTMENTS.

LOC	DIST	REVISIONS					
		#	LY#	DESCRIPTION	DATE	OWN	APVD
A	66	B1		ECR-18-012971	15AUG2018	TB	TE
		C		ECR-19-008826	06JUN2019	LG	TE
		D		ECR-20-003799	17MAR2020	JWC	TE
		E		ECR-20-010828	30JUL2020	JWC	TE

-	1	1	2119641-1	FEED CAM, AIR FEED	248	
-	1	1	2844940-3	AIR FEED MODULE	238	
-	2	2	2168400-4	SHCS, LOW HEAD, RoHS, M4 X 8	208	
-	1	1	467281-1	RETAINER, SHEAR, FLOATING	207	
-	1	1	2161936-1	HOLDER, SHEAR, FLOATING	206	
-	1	1	467500-1	SHEAR, FLOATING	205	
-	1	1	1-18028-0	WASHER, FLAT, REG M8	192	
-	REF	REF	994970-2	COUNTER, MAGNETIC	164	
-	1	1	2161937-2	STABILIZER	154	
-	1	1	455888-6	SPACER, CRIMPER	82	
-	1	1	1803607-4	DOCUMENTATION PACKAGE	71	
-	1	1	3-18032-3	SCR, SET, FLT PNT, M3 X 20.0	70	
-	1	1	2-18032-2	SCR, SET, FLT PNT, M3 X 10.0	69	
-	1	1	2119740-1	TAG, IDENTIFICATION	67	
-	2	2	2168078-1	SCREW, DRIVE, RH, RoHS, 2 x .188	66	
-	1	1	2079383-4	SCR, BHSC, RoHS (M4 X 8)	60	
-	1	1	5-18022-5	SCR, HEX HD CAP, M4 X 6.0	59	
-	4	4	2168400-1	SHCS, LOW HEAD, RoHS, M4 X 12	57	
-	2	2	2168083-2	SCR, SKT HD CAP, RoHS, M4 X 8.0	56	
-	2	2	5018030-1	NUT, HEX, REG, RoHS, M3	54	
-	2	2	986965-8	NUT, LOCK, HEX, TORQUE (M4)	53	
-	1	1	2352966-1	FEED FINGER	51	
-	1	1	18023-9	SCR, SKT HD CAP M4 X 6.0	49	
-	1	1	1-2119655-5	APPLICATOR BASIC ASSEMBLY, EF	46	
-	1	1	1803517-1	RAM ASSEMBLY, EF ATLANTIC	44	
-	1	1	1803602-1	SCR, BHSC, RoHS (M8 X 25)	41	
-	2	2	5-22278-1	SPRING, COMPRESSION	36	
-	8	8	1-18028-2	WASHER, FLAT, REG M4	33	
-	2	2	2079383-4	SCR, BHSC, RoHS (M4 X 8)	31	
-	2	2	2168083-2	SCR, SKT HD CAP, RoHS, M4 X 8.0	29	
-	1	1	690455-3	STRIPPER, FRONT CASTING	27	
-	2	2	1-2168083-6	SCR, SKT HD CAP, RoHS, M4 X 35	25	
-	1	1	2161941-1	PLATE, GUIDE, STRIP	24	
-	2	2	2-22280-7	SPRING, COMPRESSION	22	
-	1	1	2161948-1	DRAG	20	
-	1	1	683736-1	GUIDE, STRIP, REAR	19	
-	1	1	683737-1	FRONT STRIP GUIDE	18	
-	4	4	1-2079383-1	SCR, BHSC, RoHS (M6 X 12)	17	
-	1	1	4-22280-7	SPRING, COMPRESSION	13	
-	1	2	1	2161935-4	ANVIL, RIGHT HAND	8
-	1	1	1	2161957-1	DEPRESSOR, SHEAR	5
-	1	1	1	238011-2	BLOCK, CRIMPER SPACER	4
-	1	1	1	2161331-1	SPACER, WIRE FUNNEL DEPRESSOR	2
-	1	2	1	467342-3	CRIMPER, RIGHT HAND	1
-	77	72	-2	PART NO		
-				DESCRIPTION	ITEM NO	

ATLANTIC VERSION
Shown on sheets 1 of 4 & 2 of 4
(Pacific version shown on sheets 3 of 4 & 4 of 4)

DIMENSIONS:		TOLERANCES UNLESS OTHERWISE SPECIFIED:		MATERIAL:	
mm	0 PLC ±	1 PLC ±	2 PLC ±	3 PLC ±	4 PLC ±
	ANGLES	FINISH			
MATERIAL		WEIGHT	SCALE	SHEET	REV
Customer Accessible Production Drawing		00779	1:1	1 of 4	E

LOC	DIST	REVISIONS			
A	66	REV	DATE	OWN	APVD
		1	SEE SHEET 1	-	-

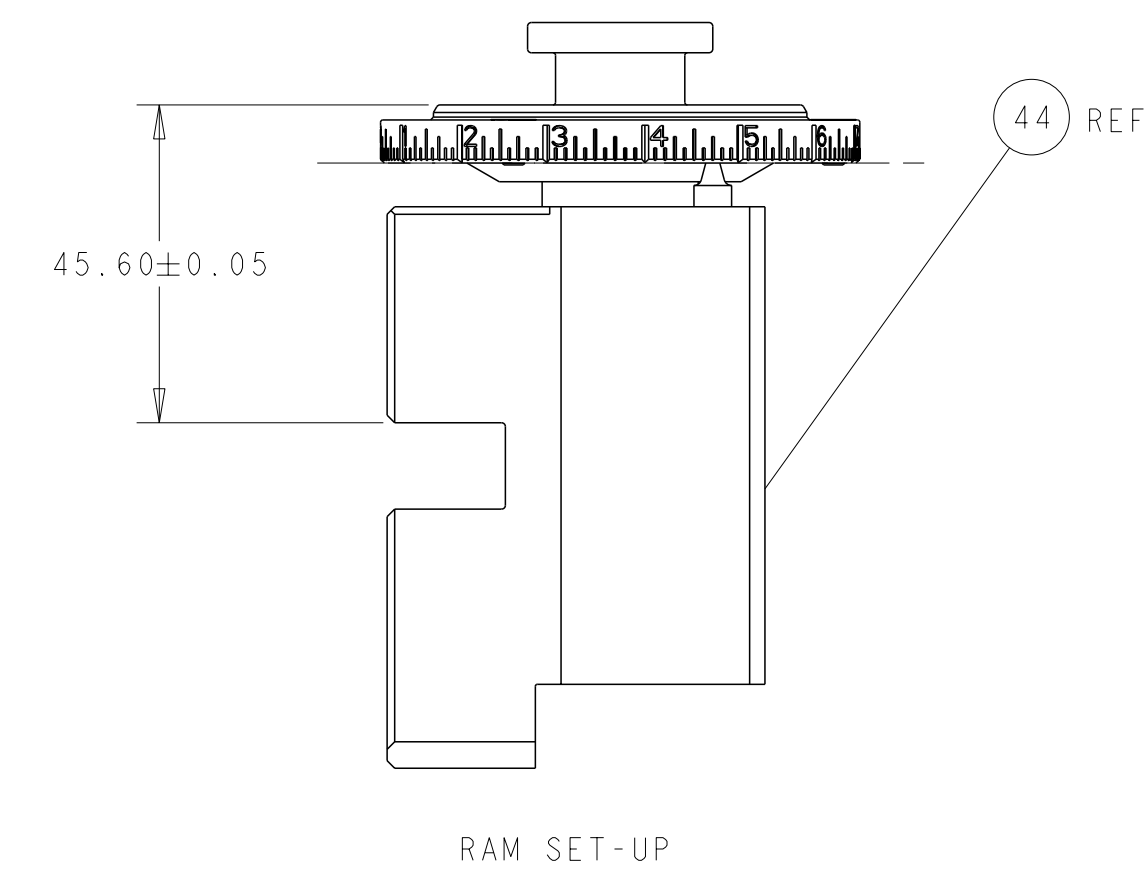

FEED TYPE

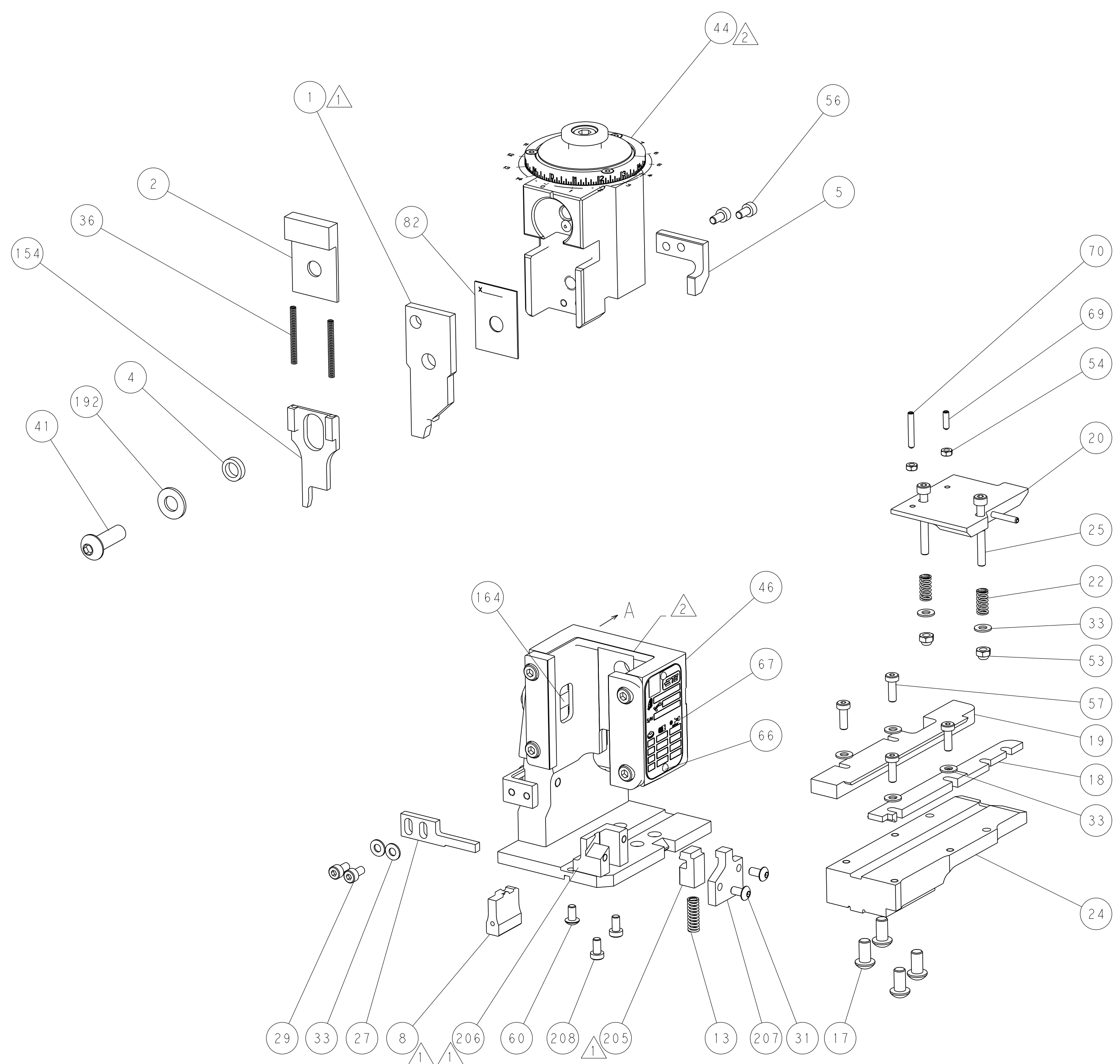
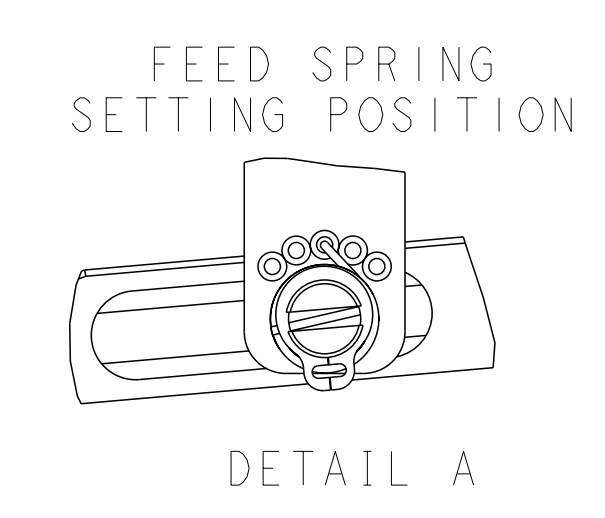
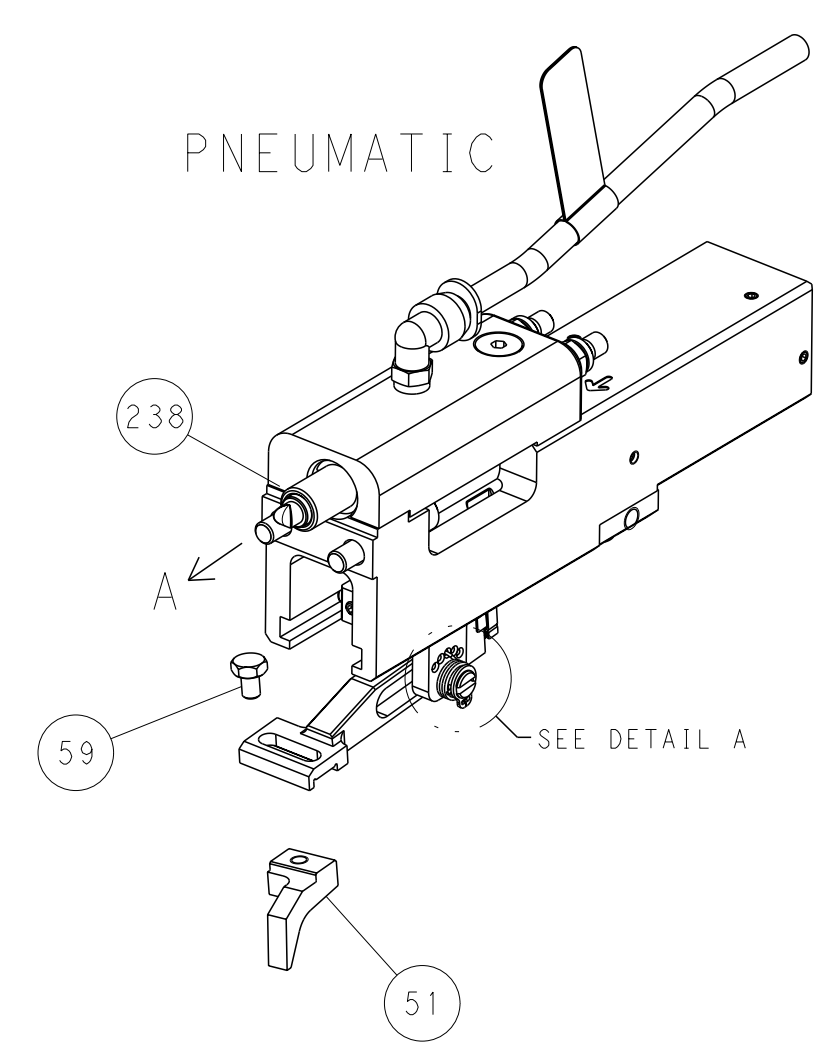

CAM POSITION

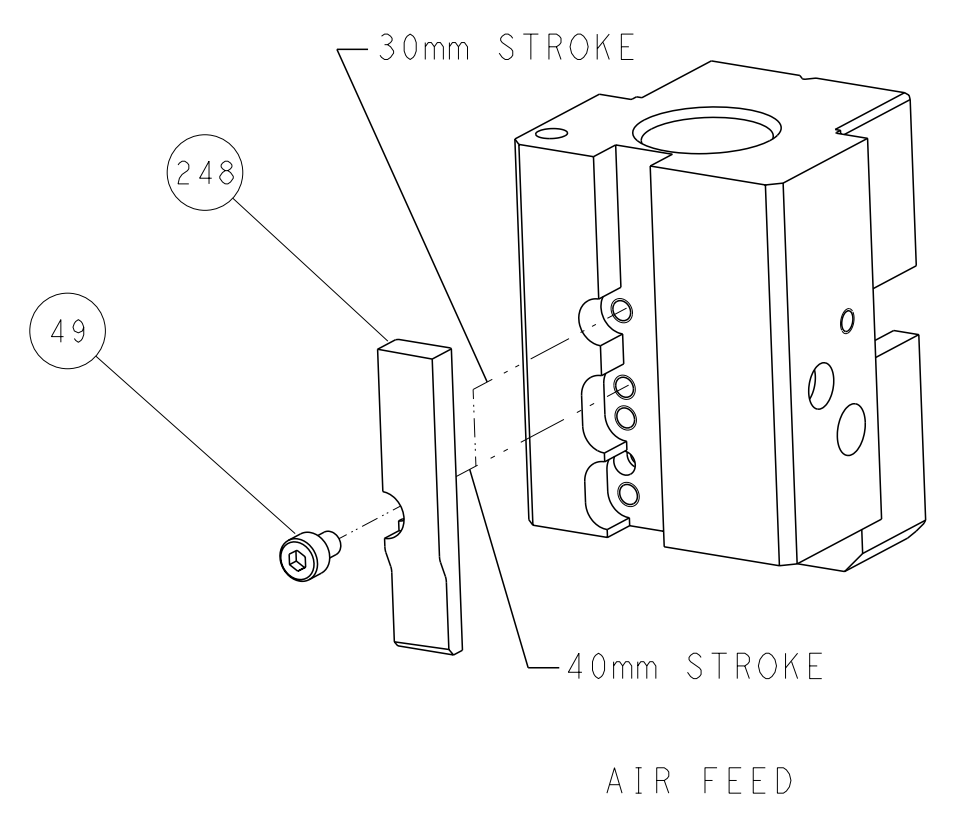

ATLANTIC VERSION
 Shown on sheets 1 of 4 & 2 of 4
 (Pacific version shown on sheets 3 of 4 & 4 of 4)

<small>THIS DRAWING IS A CONTROLLED DOCUMENT FROM TYCO ELECTRONICS CORPORATION. IT IS SUBJECT TO CHANGE AND THE CONTROL AND RESTRICTION DESIGNATION SHOULD BE CONTACTED FOR THE LATEST REVISION.</small>		DWN: HOFFNER 11APRIL2012 CHK: T. ELBIN 12APRIL2012 APVD: T. ELBIN 12APRIL2012	TE Connectivity Harrisburg, PA 17105-3608
DIMENSIONS: mm TOLERANCES UNLESS OTHERWISE SPECIFIED: 0 PLC ± 1 PLC ± 2 PLC ± 3 PLC ± 4 PLC ± ANGLES FINISH ±		NAME: Ocean End Feed Applicator SIZE: A1 CAGE CODE: 00779 DRAWING NO: C=2150278	RESTRICTED TO: - SCALE: 1:1 SHEET: 2 of 4 REV: E
MATERIAL: - FINISH: -		WEIGHT: - Customer Accessible Production Drawing	SHEETS 3 & 4 ARE NOT REQUIRED FOR ATLANTIC VERSION

PART NUMBER	REVISION	DESCRIPTION	FEED TYPE
2-2150278-2	E	PNEUMATIC	SERVO LATCH PLATE
7-2150278-7	A	CRIMP TOOLING KIT	-

PACIFIC VERSION TERMINATOR
 INTERFACE ADAPTER

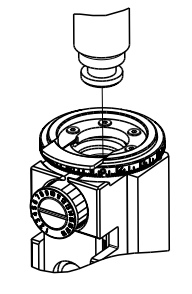

APPLICATOR DATA		
CRIMP	SIZE	TYPE
WIRE	5.11 mm [.201]	D
INSUL	-	-
APPL INSTRUCTIONS 408-35043		

TERMINAL DATA: TE TERMINAL		TE CRIMP SPECIFICATION	
TERMINAL NAME: RECPT, ULTRA-FAST FLAG, .187 SERIES			
WIRE STRIP LENGTH 7.51-8.33 mm [.296-.328 IN]		INSULATION DIAMETER RANGE Ø 4.19 mm MAX[.165 IN MAX]	
TERMINAL APPLICATION SPECIFICATION 114-2123		-	
TERMINALS APPLIED			
TE TERMINAL	TE TERMINAL	TE TERMINAL	TE TERMINAL
2-520334-2	9-520334-2	5-520336-2	
5-520334-2	2-520336-2	9-520336-2	

WIRE SIZE	CRIMP HEIGHT mm [INCH]	CRIMP HEIGHT REFERENCE SETTING	Ø SOLDER
18 OR (2) 22	1.79+/-0.05 [.070+/-0.002]	5.0	.19 in [4.83mm]
22 OR 20	1.65+/-0.05 [.065+/-0.002]	6.5	.19 in [4.83mm]

- RECOMMENDED SPARE PARTS
 - REFER TO SUPPLIED INSTRUCTION SHEET FOR CLEANING, LUBRICATION AND STORAGE OF APPLICATOR.
 - TO CHECK CRIMP HEIGHT, CRIMP SOLDER (Ø.19 IN [4.83mm] 60/40 SOLID CORE) AND MEASURE AT CENTER OF SLUG.
-
- CRIMP HEIGHT REFERENCE SETTING WAS THE SETTING USED WHEN THE APPLICATOR WAS QUALIFIED AT THE FACTORY. ADJUSTMENT MAY BE NECESSARY WHEN RUNNING APPLICATOR IN THE FIELD.
 - TERMINAL PITCH NOT COMPATIBLE WITH MECHANICAL FEED.
 - 6. UNLESS SPECIFIED OTHERWISE TORQUE VALUES SHALL BE USED PER DOCUMENT, 101-35000.

***WARNING**
 ON INSTALLATION, SET WIRE DISC TO CRIMP HEIGHT REFERENCE SETTING FOR LARGEST WIRE SIZE. CRIMP HEIGHT REFERENCE SETTINGS GREATER THAN THE VALUE SHOWN MAY CAUSE DAMAGE TO THE CRIMP TOOLING. REFER TO THE INSTRUCTION SHEET FOR PROPER SETUP AND ADJUSTMENTS.

LOC	DIST	REVISIONS					
		#	LY#	DESCRIPTION	DATE	OWN	APVD
A	66	-	-	SEE SHEET 1	-	-	-

-	1	2844940-3	AIR FEED MODULE	238
-	2	2168083-9	SCR, SKT HD CAP, RoHS, M4 X 20	209
-	1	467281-1	RETAINER, SHEAR, FLOATING	207
-	1	2161936-1	HOLDER, SHEAR, FLOATING	206
-	1	467500-1	SHEAR, FLOATING	205
-	1	1-18028-0	WASHER, FLAT, REG M8	192
-	4	2079383-9	SCR, BHSC, RoHS (M6 X 20)	186
-	REF	994970-2	COUNTER, MAGNETIC	164
-	1	2161937-2	STABILIZER	154
-	1	2119641-2	FEED CAM, AIR FEED	152
-	1	2168083-8	SCR, SKT HD CAP, RoHS, M4 X 16	144
-	1	1-2119655-6	APPLICATOR BASIC ASSEMBLY, EF	141
-	1	1803518-1	RAM ASSEMBLY, EF PACIFIC	140
-	1	455888-6	SPACER, CRIMPER	82
-	1	1803607-4	DOCUMENTATION PACKAGE	71
-	1	3-18032-3	SCR, SET, FLT PNT, M3 X 20.0	70
-	1	2-18032-2	SCR, SET, FLT PNT, M3 X 10.0	69
-	1	2119740-1	TAG, IDENTIFICATION	67
-	2	2168078-1	SCREW, DRIVE, RH, RoHS, 2 x .188	66
-	1	5-18022-5	SCR, HEX HD CAP, M4 X 6.0	59
-	4	2168400-1	SHCS, LOW HEAD, RoHS, M4 X 12	57
-	2	2168083-2	SCR, SKT HD CAP, RoHS, M4 X 8.0	56
-	2	5018030-1	NUT, HEX, REG, RoHS, M3	54
-	2	986965-8	NUT, LOCK, HEX, TORQUE (M4)	53
-	1	2352966-1	FEED FINGER	51
-	1	18023-9	SCR, SKT HD CAP M4 X 6.0	49
-	1	1803602-1	SCR, BHSC, RoHS (M8 X 25)	41
-	2	5-22278-1	SPRING, COMPRESSION	36
-	8	1-18028-2	WASHER, FLAT, REG M4	33
-	2	2079383-4	SCR, BHSC, RoHS (M4 X 8)	31
-	2	2168083-2	SCR, SKT HD CAP, RoHS, M4 X 8.0	29
-	1	690455-3	STRIPPER, FRONT CASTING	27
-	2	1-2168083-6	SCR, SKT HD CAP, RoHS, M4 X 35	25
-	1	2161941-1	PLATE, GUIDE, STRIP	24
-	2	2-22280-7	SPRING, COMPRESSION	22
-	1	2161948-1	DRAG	20
-	1	683736-1	GUIDE, STRIP, REAR	19
-	1	683737-1	FRONT STRIP GUIDE	18
-	1	4-22280-7	SPRING, COMPRESSION	13
-	1	2161935-4	ANVIL, RIGHT HAND	8
-	1	2161957-1	DEPRESSOR, SHEAR	5
-	1	238011-2	BLOCK, CRIMPER SPACER	4
-	1	2161331-1	SPACER, WIRE FUNNEL DEPRESSOR	2
-	1	467342-3	CRIMPER, RIGHT HAND	1
-	77-22	PART NO	DESCRIPTION	ITEM NO

PACIFIC VERSION
 Shown on sheets 3 of 4 & 4 of 4
 (Atlantic version shown on sheets 1 of 4 & 2 of 4)

<small>THIS DRAWING IS UNPUBLISHED. RELEASED FOR PUBLICATION. IF SUBJECT TO CHANGE AND FOR THE LATEST REVISIONS, CONTACT THE DRAWING ENGINEER OR THE LATEST REVISION.</small>		DWN: HOFFNER 11APRIL2012 CHK: T. ELBIN 12APRIL2012 APVD: T. ELBIN 12APRIL2012	NAME: TE Connectivity Harrisburg, PA 17105-3608
DIMENSIONS: mm 0 PLC ± 1 PLC ± 2 PLC ± 3 PLC ± 4 PLC ± ANGLES FINISH ±	TOLERANCES UNLESS OTHERWISE SPECIFIED: ±	PRODUCT SPEC APPLICATION SPEC WEIGHT: - SCALE: 1:1	SIZE: A1 CAGE CODE: 00779 DRAWING NO: 2150278 RESTRICTED TO: - SHEET 3 OF 4
MATERIAL: -		CUSTOMER ACCESSIBLE PRODUCTION DRAWING	SHEETS 1 & 2 ARE NOT REQUIRED FOR PACIFIC VERSION

LOC	DIST	REVISIONS			
A	66	REV	DATE	OWN	APVD
		-	SEE SHEET 1	-	-

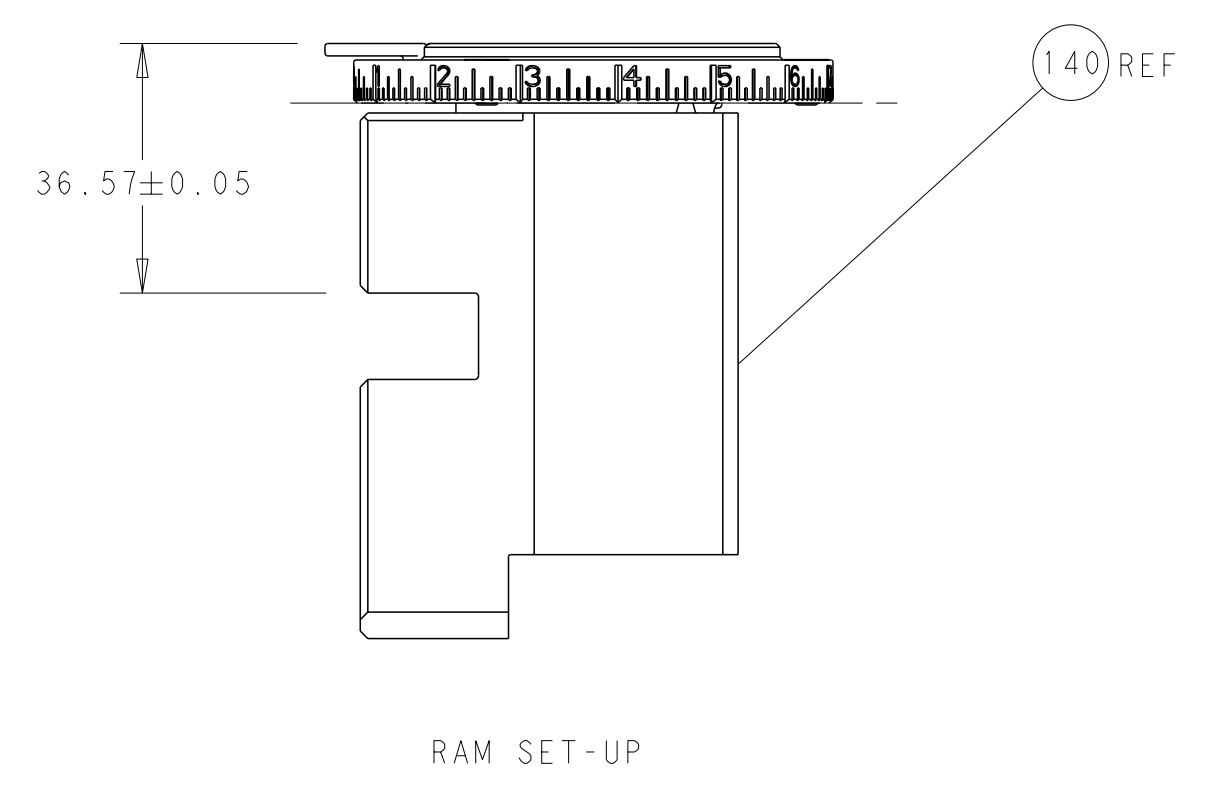

FEED TYPE

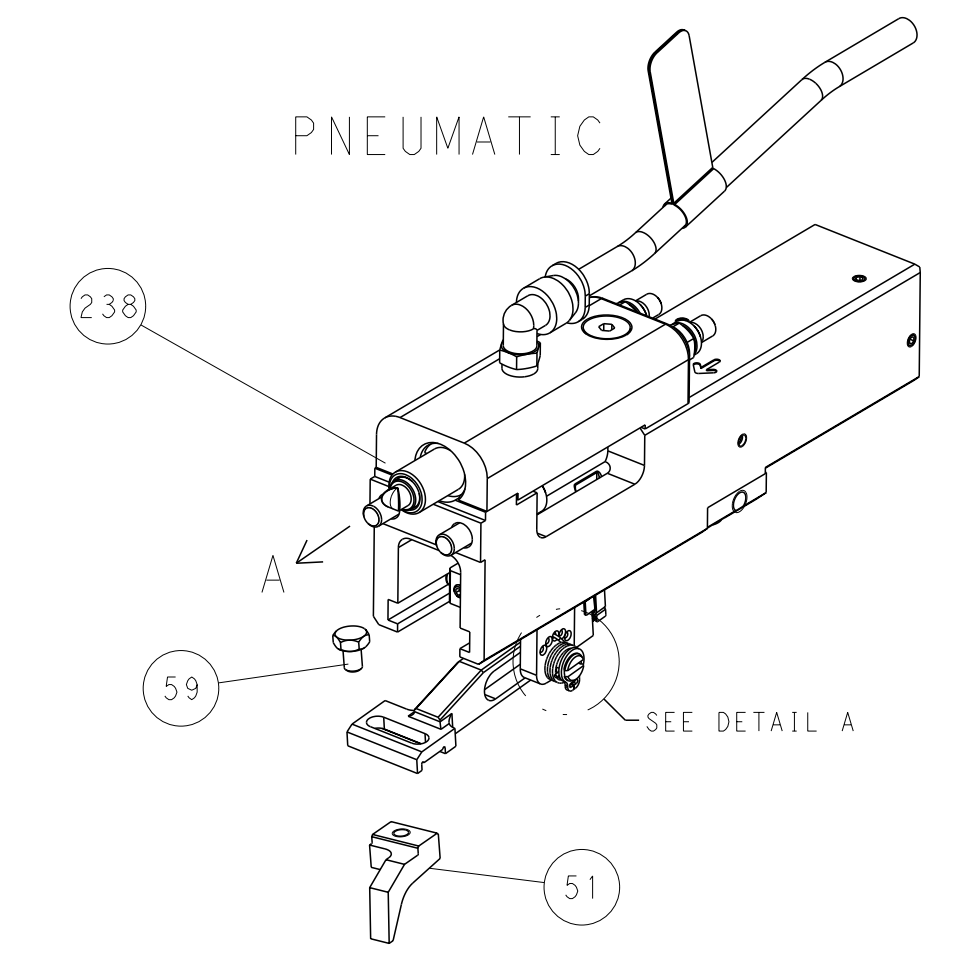

FEED SPRING SETTING POSITION

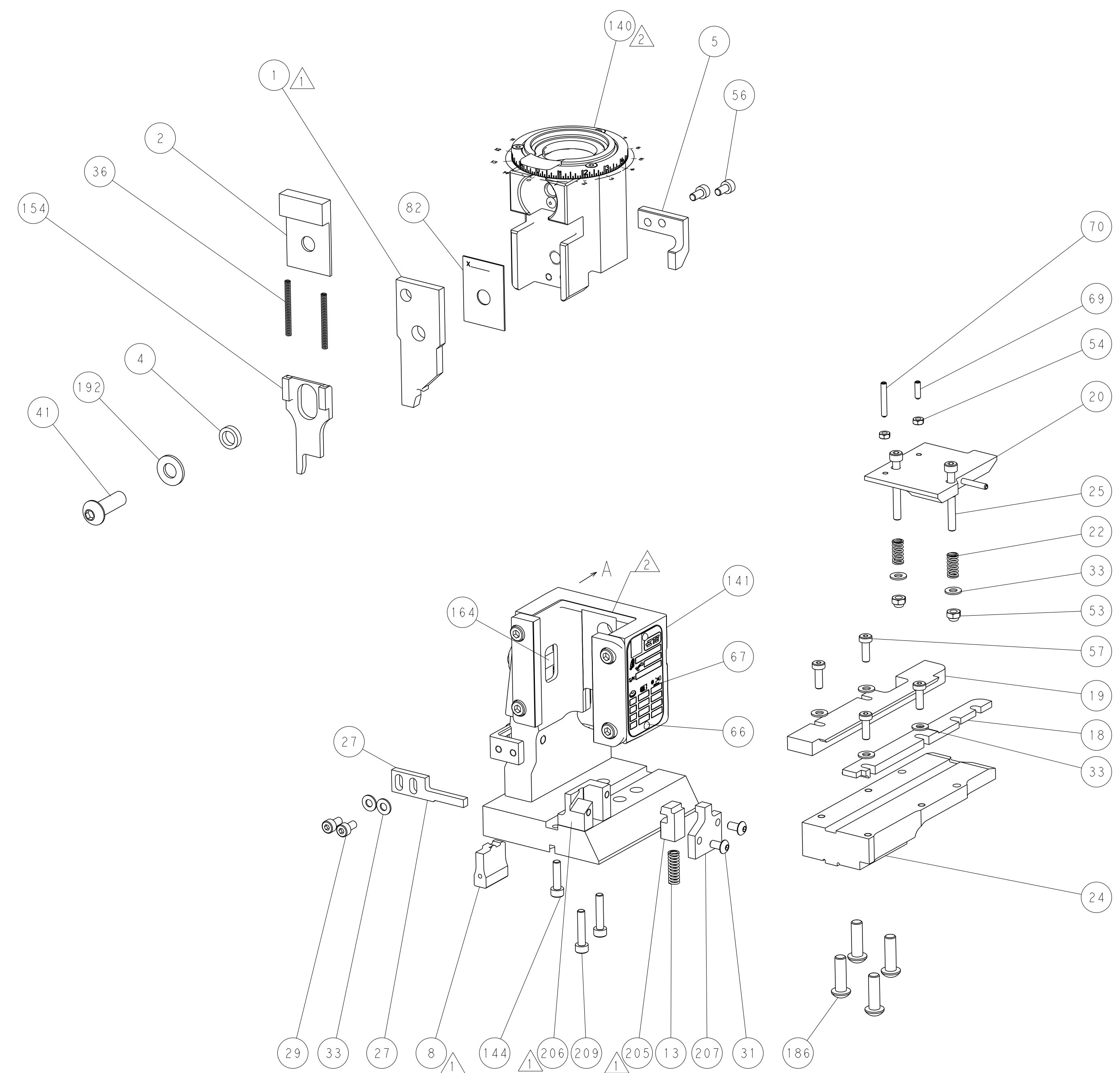
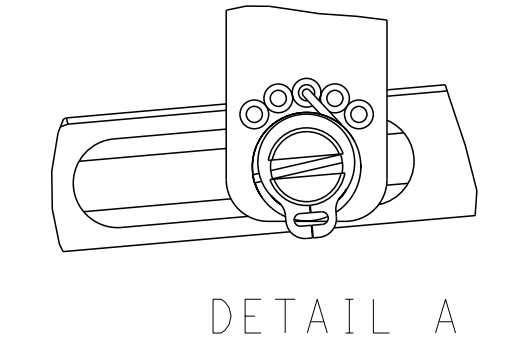

CAM POSITION

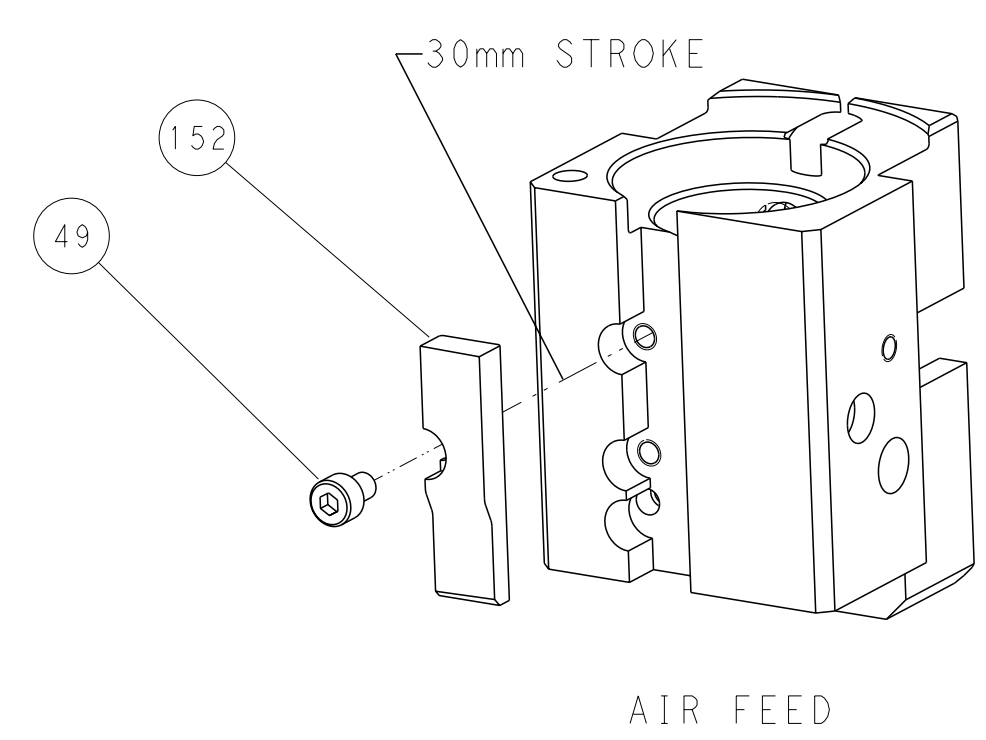

PACIFIC VERSION
 Shown on sheets 3 of 4 & 4 of 4
 (Atlantic version shown on sheets 1 of 4 & 2 of 4)

<small>THIS DRAWING IS A CONTROLLED DOCUMENT FOR TYCO ELECTRONICS CORPORATION. IT IS SUBJECT TO CHANGE AND ITS CONTENTS AND EXISTING DISCRETION SHOULD BE CONTACTED FOR THE LATEST REVISION.</small>		DWN: HOFFNER 11APRIL2012 CHK: T.ELBIN 12APRIL2012 APVD: T.ELBIN 12APRIL2012	TE Connectivity Harrisburg, PA 17105-3608
DIMENSIONS: mm TOLERANCES UNLESS OTHERWISE SPECIFIED: 0 PLC ± 1 PLC ± 2 PLC ± 3 PLC ± 4 PLC ± ANGLES FINISH *		NAME: Ocean End Feed Applicator SIZE: A1 CAGE CODE: 00779 DRAWING NO: C-2150278 WEIGHT: - SCALE: 1:1 SHEET: 4 of 4 REV: E	RESTRICTED TO: -
MATERIAL: -		Customer Accessible Production Drawing	