

REVISIONS					
P	LTN	DESCRIPTION	DATE	DMN	APVD
A		INITIAL RELEASE	18OCT18	B.Z	W.W
A1		ECR-19-019964	23DEC19	B.Z	W.W
A2		ECN-23-221302	11JUL23	M.X	F.P

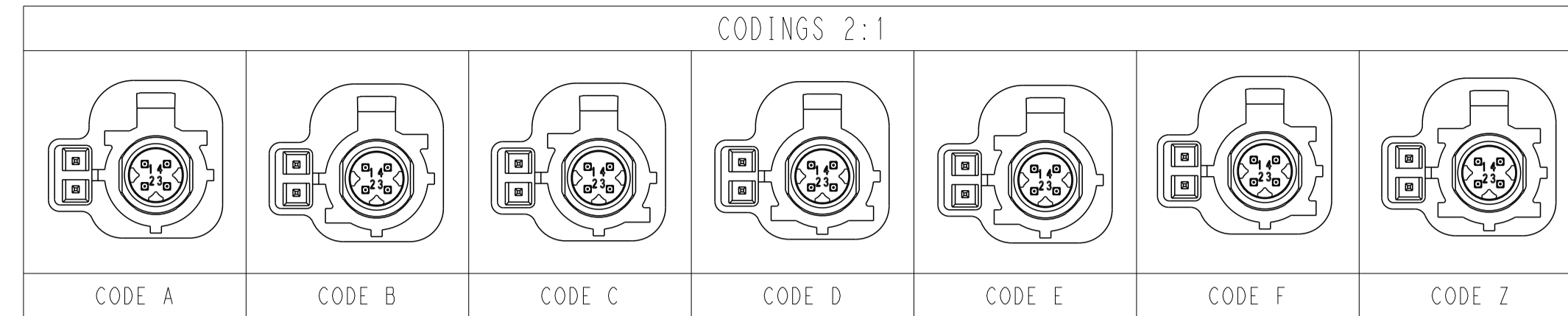

- 1 HSD INTERFACE DESIGN ARE LEFT TO TE CONNECTIVITY
- 2 ALL DIMENSIONS IN BRACKETS () FOR INFORMATION ONLY
- 3 PACKAGING: TAPE AND REEL
- 4 MARKING OF 100% TEST PASSED
- 5 CENTER OF GRAVITY
- 6 AREA OF VACUUM GRIPPER

WEIGHT (g): 3.2
 AS SHOWN CODING Z

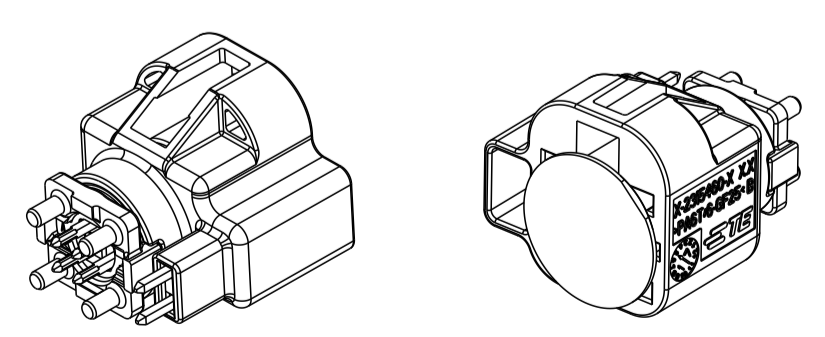
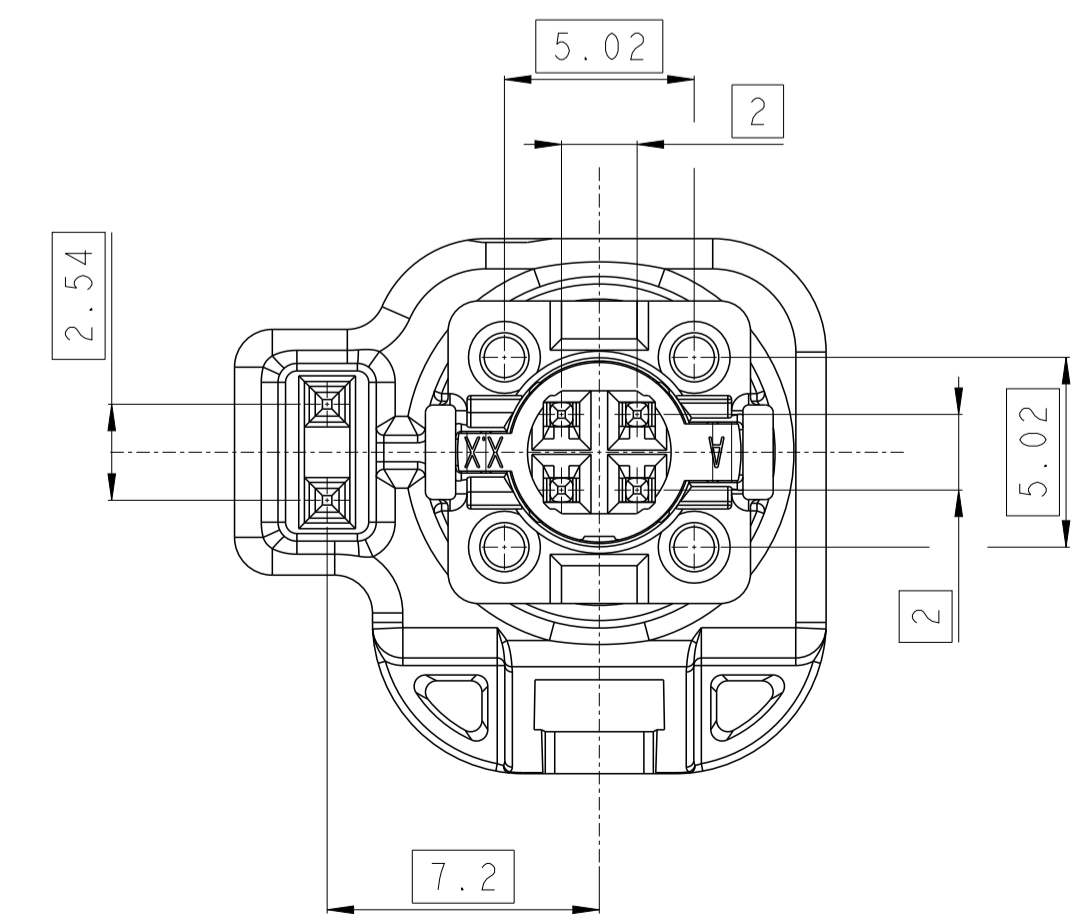
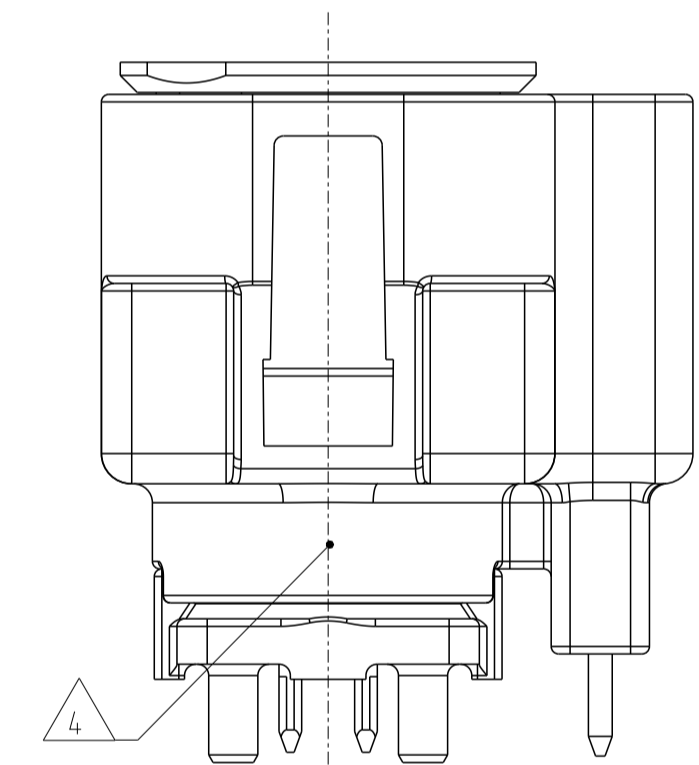
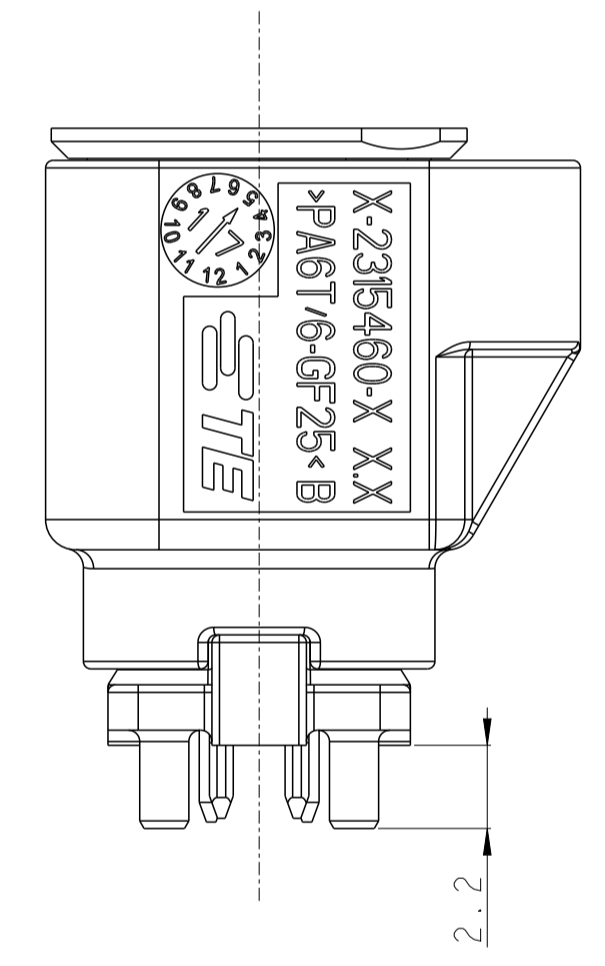
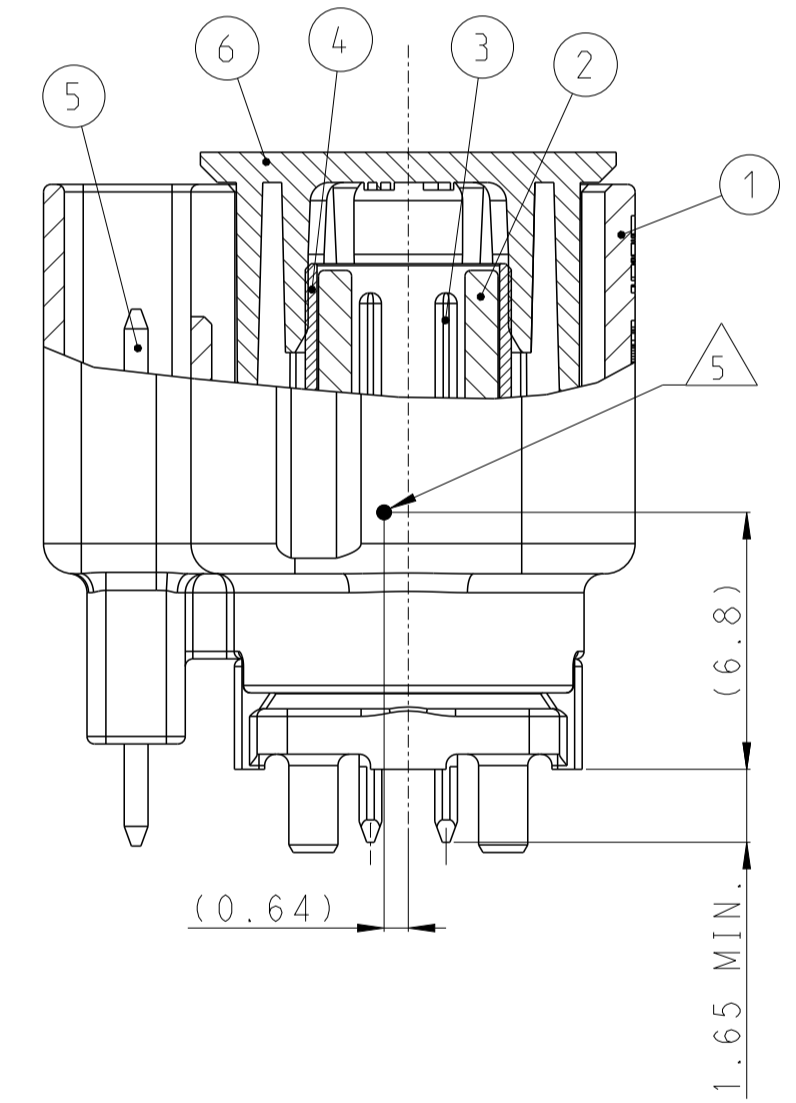
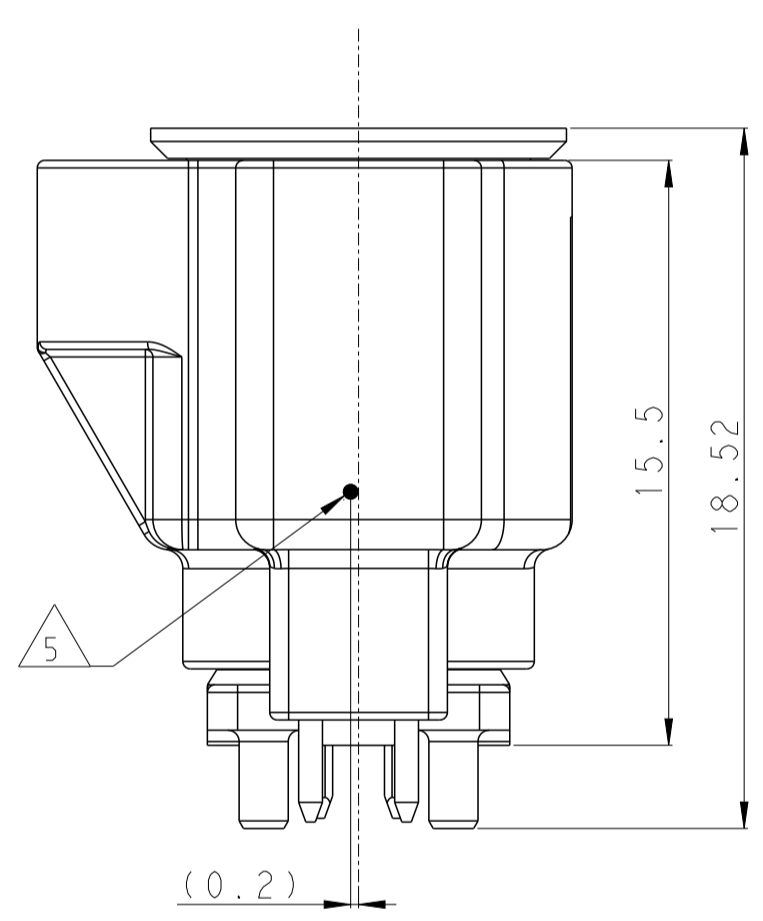
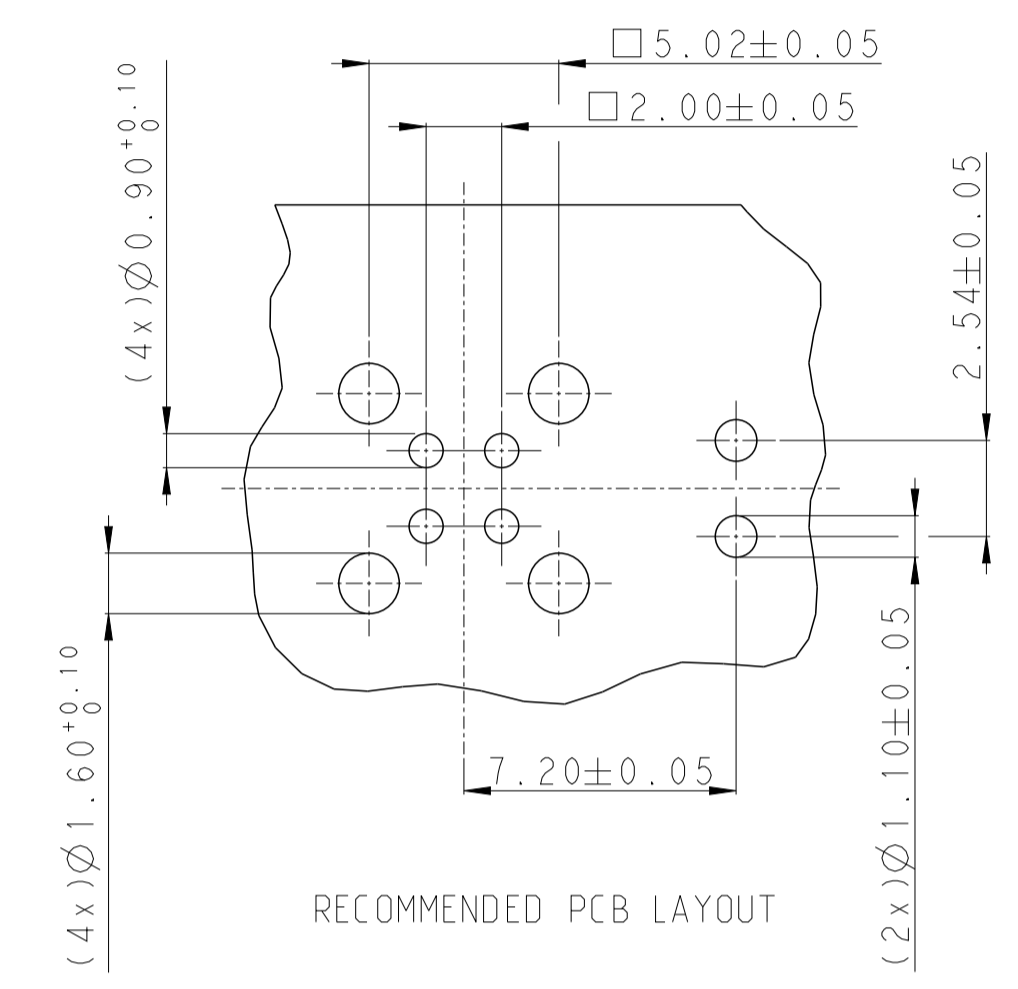
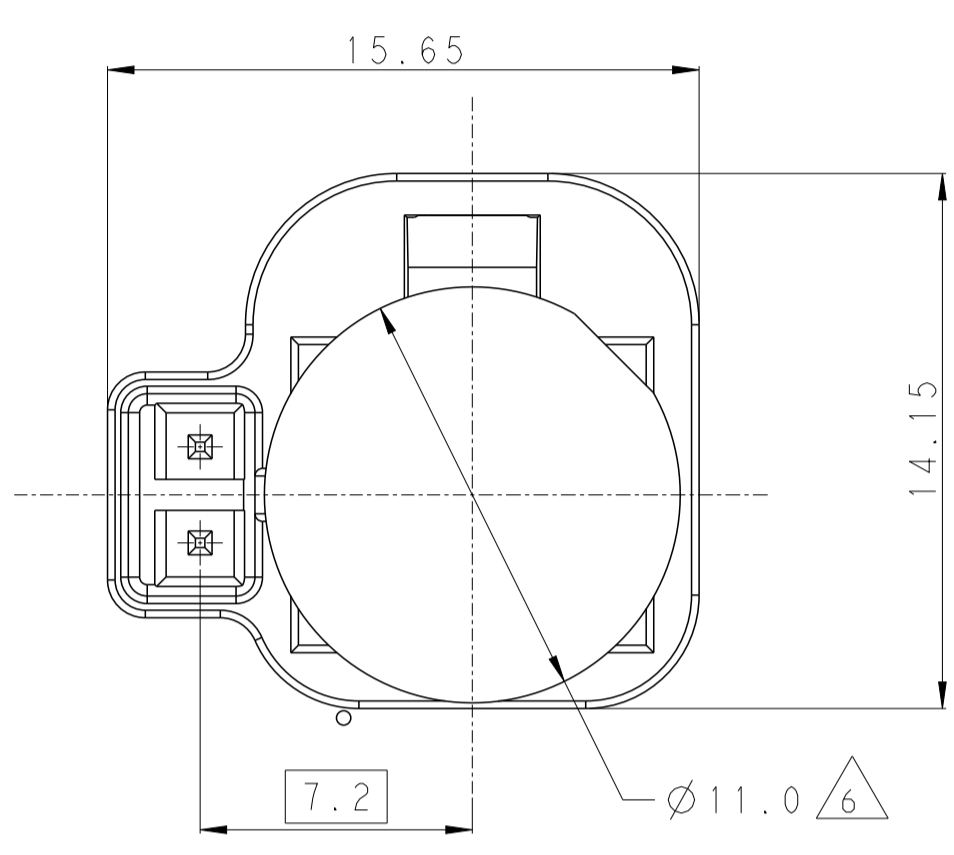

SCALE 2:1

QTY	CODE	DESCRIPTION	MATERIAL	FINISH COLOR, SIMILAR RAL	ITEM NO.
1		PICK-UP CAP	NYLON	BLACK	6
2		MOS PIN	CuSn4	TIN PLATING	5
1		SHIELDING BODY	Zn ALLOY	SOLDER SIDE: TIN PLATING. INTERFACE SIDE(OUTER CONTACT): TIN PLATING.	4
4		CONTACT PIN	CuSn4	SOLDER SIDE: TIN PLATING. INTERFACE SIDE: GOLD PLATING	3
1		CAVITY BLOCK	PA4T	BLACK	2
				WATER BULE / 5021	1
				NUT BROWN / 8011	
				LEAF GREEN / 6002	
				CLARET VIOLET / 4004	
				SIGNAL BLUE / 5005	
				CREAM WHITE / 9001	
				JET BLACK / 9005	

QUANTITY	CODE	DESCRIPTION	MATERIAL	FINISH COLOR, SIMILAR RAL	ITEM NO.
0-1 0-2 0-3 0-4 0-5 0-6 0-9				ASSY NO. X-2345180-Y	
A B C D E F Z				ASSY CODE	
1 1 1 1 1 1 1				REVISION	

THIS DRAWING IS A CONTROLLED DOCUMENT. DIMENSIONS: TOLERANCES UNLESS OTHERWISE SPECIFIED: 0 PLC ±0.5, 1 PLC ±0.5, 2 PLC ±0.5, 3 PLC ±0.5, 4 PLC ±0.5, ANGLES ±0.5. MATERIAL: SEE TABLE. FINISH: -

DMN: ML-XU 11JUL2023
 CHK: C_PAN 11JUL2023
 APVD: F_PAN 11JUL2023

NAME: 6 POS HSD 180DEG HEADER ASSY WITH PLASTIC CAP
 PRODUCT SPEC: 108-101388
 APPLICATION SPEC: 116-32195
 WEIGHT: -

SCALE: 5:1 SHEET 1 OF 1 REV: A2