

THIS DRAWING IS UNPUBLISHED. RELEASED FOR PUBLICATION 20
 © COPYRIGHT 20 BY - ALL RIGHTS RESERVED.

REVISIONS					
P	LTR	DESCRIPTION	DATE	DWN	APVD
B		SEE ECR-20-017293	08DEC2020	L.G	I.Y
C		SEE ECR-21-002821	17MAR2021	L.G	I.Y
C1		ECN-21-127853	24NOV2021	L.G	Z.Z
C2		ECN-24-258780	03APR2024	J.S	Z.Z

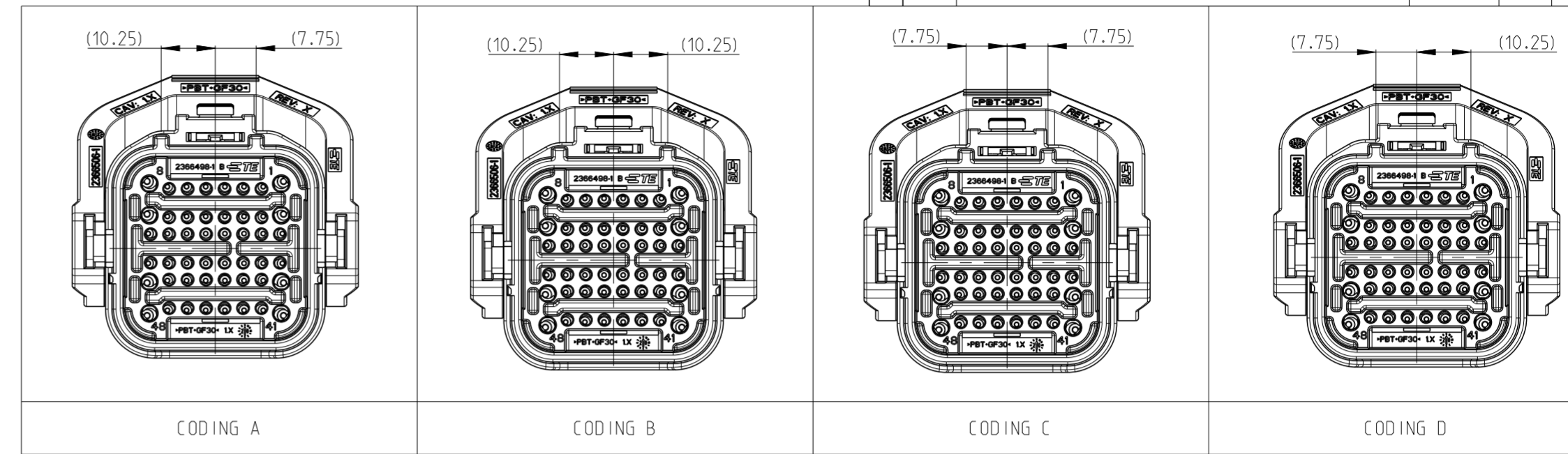
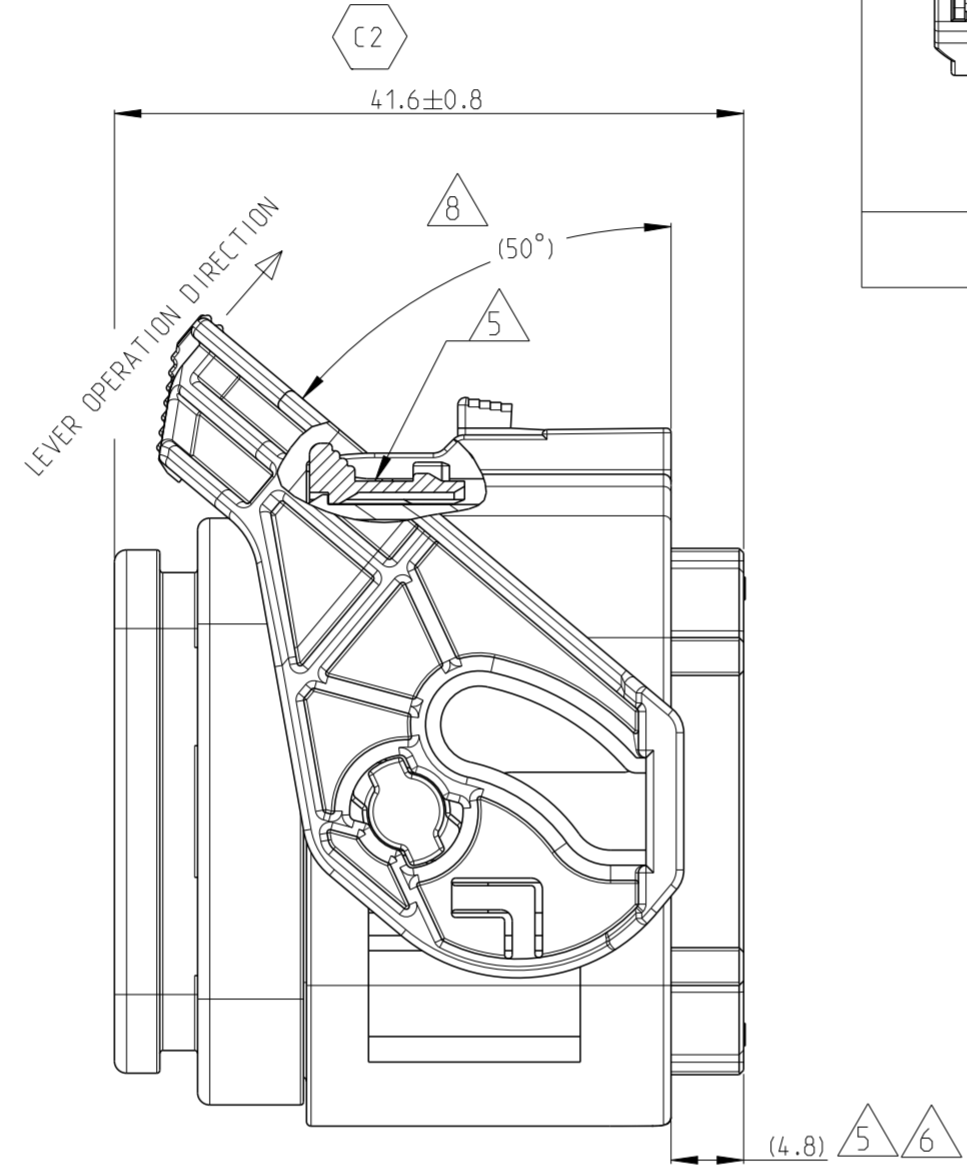
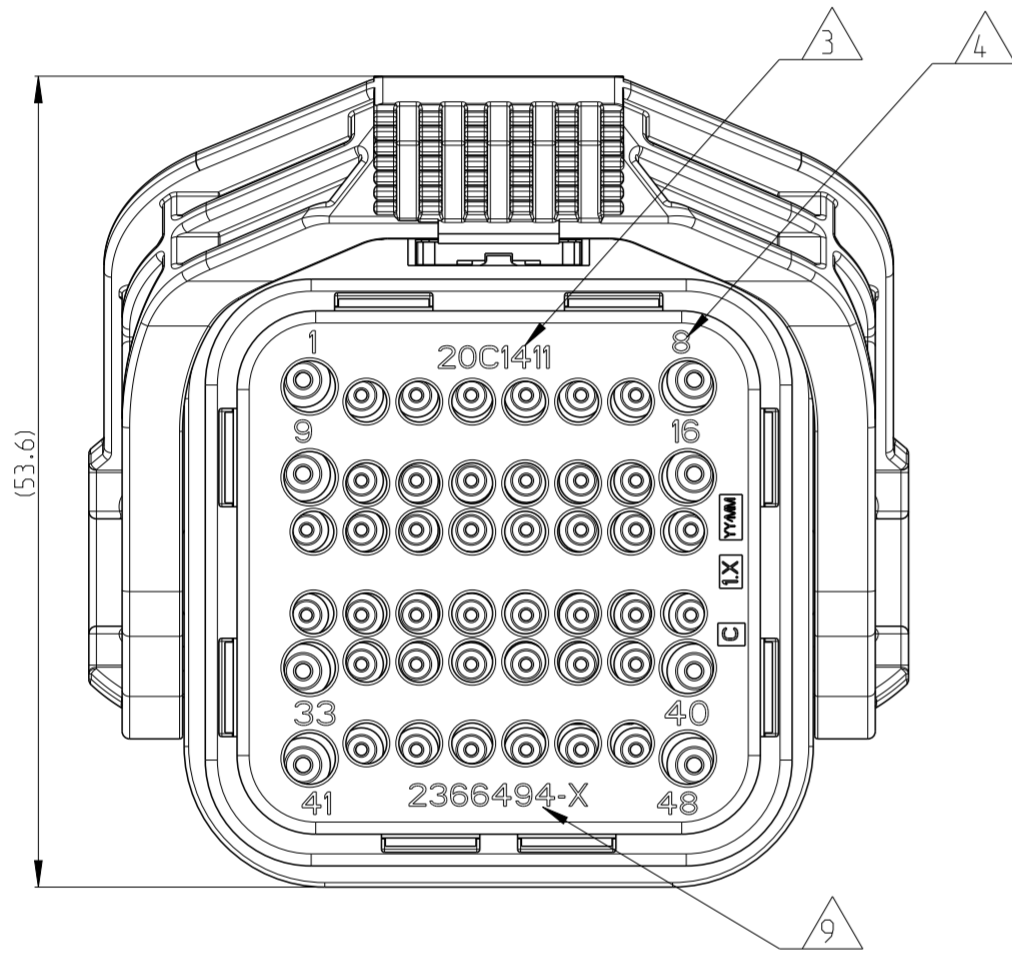
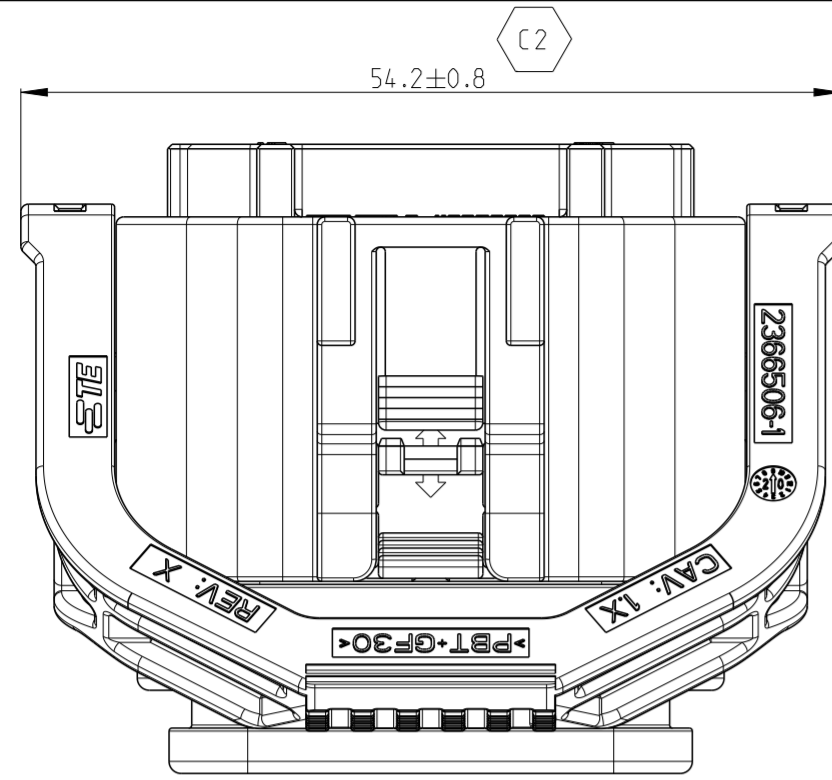

- THIS PLUG MATES WITH TAB HOUSING ASSEMBLY PN 2366509-X, OR 2-2366509-X (X=1, 2, 3, 4 FOR VARIOUS CODE).
- MATERIAL SEE TABLE
- DATE CODE: IDENTIFIES THE YEAR, MONTH, DAY AND HOUR OF ASSEMBLY.
 YEAR: FIRST AND SECOND DIGITS(20=2020)
 MONTH: THIRD DIGIT , EXCLUDING 1 ; A=JAN, B=FEB, C=MARCH...(K=OCTOBER)
 DAY: FOURTH AND FIFTH DIGITS(14=14th DAY)
 HOUR: SIXTH AND SEVENTH DIGITS(11=11AM)
- IDENTIFICATION FOR CABLE PINOUT.
- TPA AND CPA SEATED ON PRE-LOCK POSITION FOR DELIVERY.
- PULL TPA TO PRE-LOCK BEFORE TERMINAL INSERTION IN CASE OF TPA BEING HIT TO END-LOCK POSITION.
- REFER TO 114-151001 FOR DT SIZE 16 TERMINAL APPLICATION SPECIFICATION. REFER TO 114-151003 FOR DT SIZE 20 TERMINAL APPLICATION SPECIFICATION. APPLICABLE TERMINAL PART NUMBERS AND WIRE SIZE:

TERMINAL PN	WIRE SIZE (MM2)	INSULATION WIRE (MM2)	PIOUT NUMBER
16#	1.0-2.5	∅1.9-∅3.0	1,8,9,16,33,40,41,48
20#	0.5-1.5	∅1.4-∅2.4	OTHER PINS

- LEVER SEATED ON PRE-LOCK POSITION FOR DELIVERY.
- LASER PRODUCT PN. SUCH AS "--1" MEANS 2366494-1.
- REFER TO DRAWING 2373921 FOR APPLICABLE PART NO. OF SEALING PLUG.

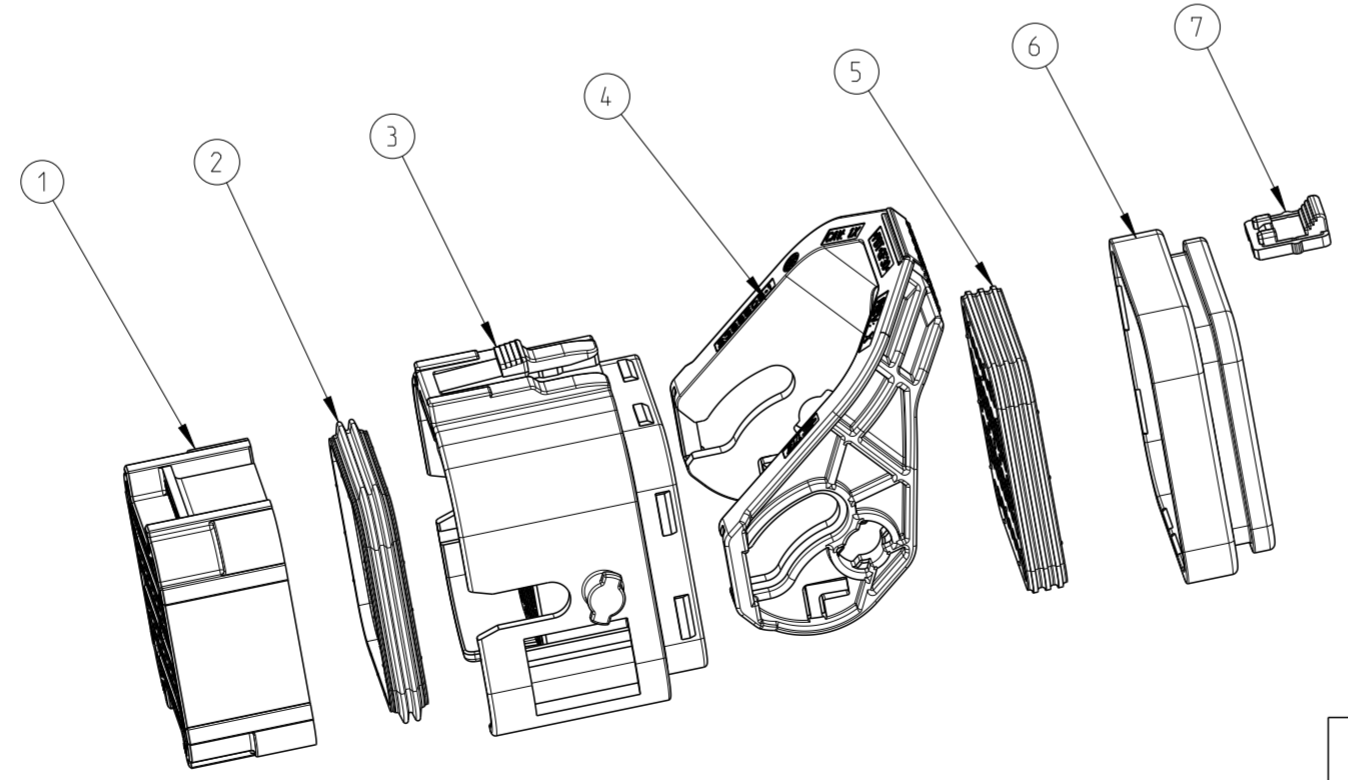
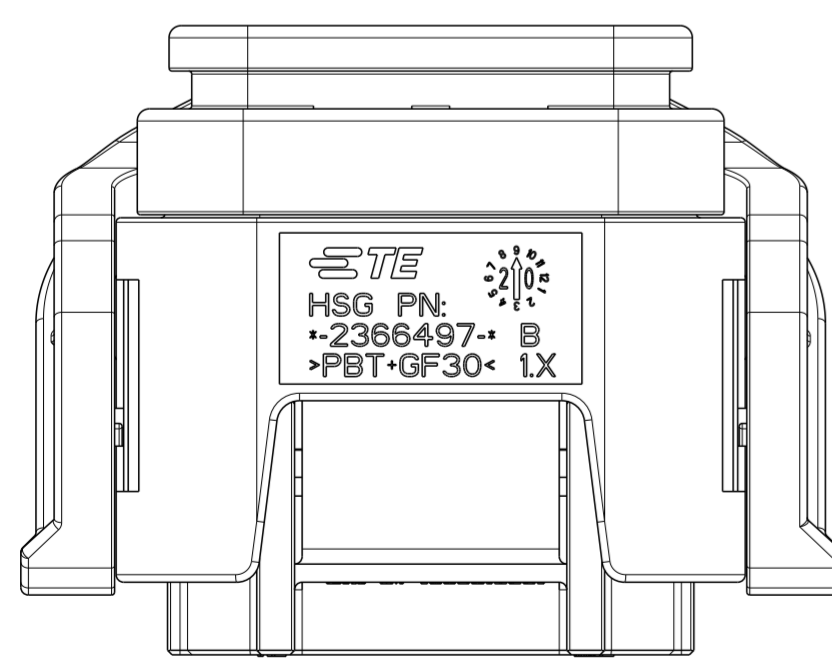

QTY.	REQUEST PER ASSY	COLOR	MATERIAL	DESCRIPTION	ITEM NO					
1	1	1	1	RED	PBT-GF15	CPA	7			
1	-	-	-	BLUE	PBT-GF30	REAR CAP	6			
-	1	-	-	GREEN						
-	-	1	-	GREY						
-	-	-	-	BLACK	PBT-GF30	HOUSING CODING D HOUSING CODING C HOUSING CODING B HOUSING CODING A	3			
1	1	1	1	RUST RED				VMQ	GROMMET	5
1	1	1	1	YELLOW				PBT-GF30	LEVER	4
1	-	-	-	BLUE				PBT-GF30	HOUSING CODING D HOUSING CODING C HOUSING CODING B HOUSING CODING A	3
-	1	-	-	GREEN						
-	-	1	-	GREY						
-	-	-	-	BLACK	PBT-GF30	RADIAL SEAL	2			
1	1	1	1	RUST RED				VMQ		
1	1	1	1	YELLOW	PBT-GF30	TPA	1			
QTY. REQUEST PER ASSY						REVISION OF EACH ASSY PN				
A	A	A	A	TE ASSEMBLY PN						
--4	--3	--2	--1							

THIS DRAWING IS A CONTROLLED DOCUMENT.

DWN: X.LI 10FEB2020
 CHK: W.WU 02MAR2020
 APVD: J.YIN 05MAR2020

PRODUCT SPEC: 108-101662
 APPLICATION SPEC: -

WEIGHT: -

CUSTOMER DRAWING

STE TE Connectivity

NAME: NTS 48P PLUG ASSEMBLY

SIZE: A2 CAGE CODE: - DRAWING NO: C-2366494 RESTRICTED TO: -

SCALE: 2:1 SHEET: 1 OF 1 REV: C2