

LOC		DIST		REVISIONS					
AF		50		P	LTR	DESCRIPTION	DATE	DWN	APVD
					J	REVISED PER ECR-13-005733	23AUG13	KH	PD

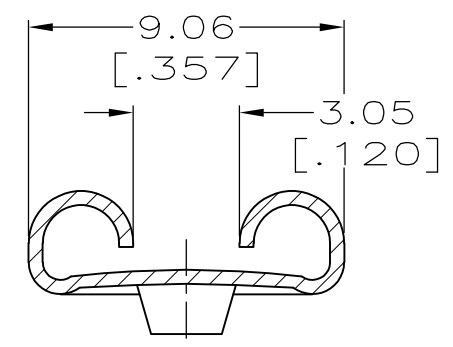

SECTION A-A  
SCALE 5:1

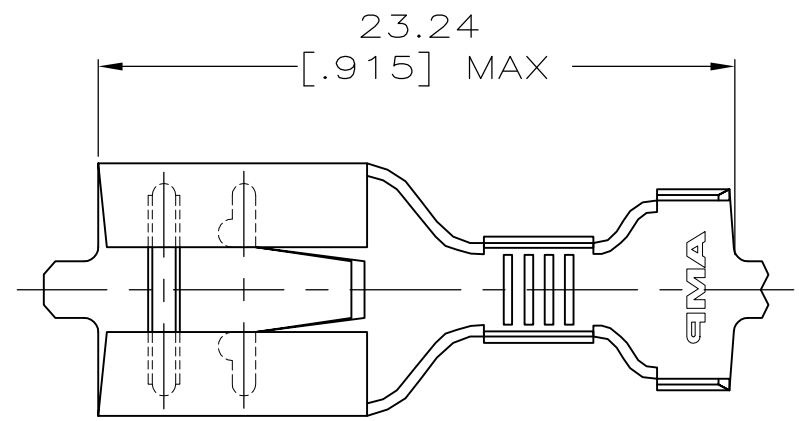
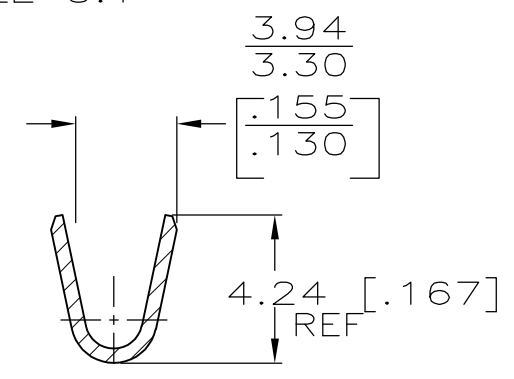
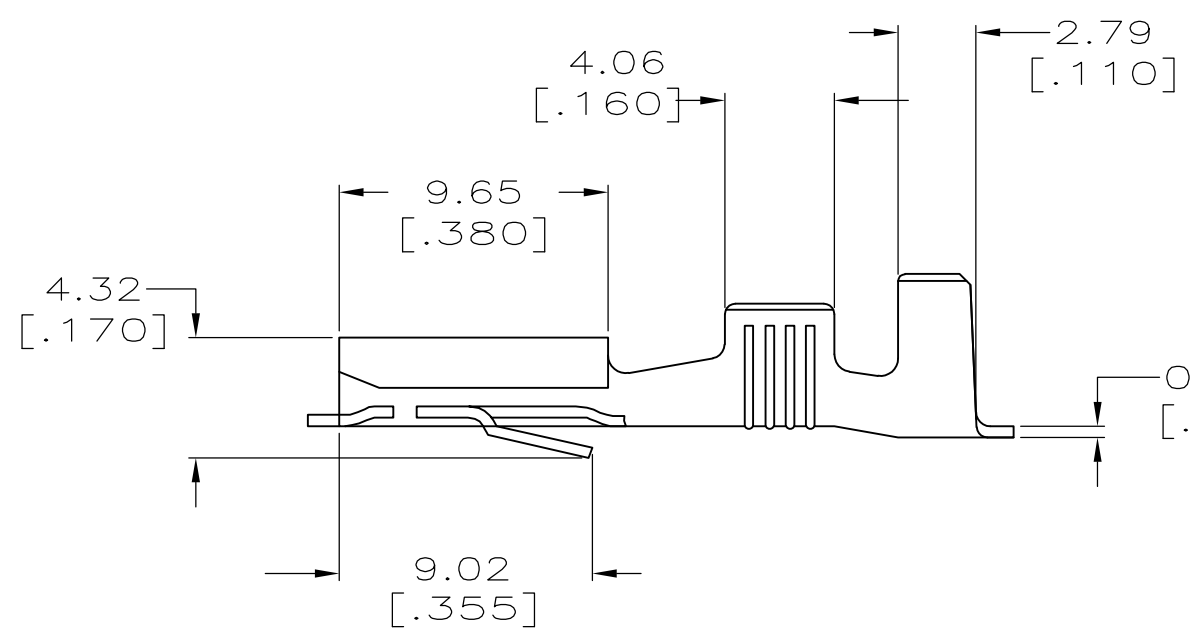

SECTION B-B  
SCALE 5:1

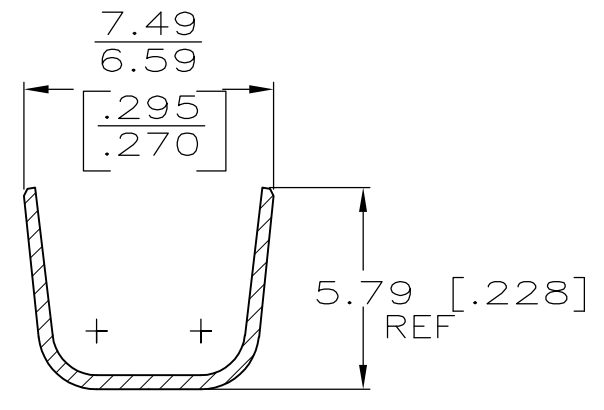

SECTION C-C  
SCALE 5:1

1 CONTINUOUS STRIP ON REELS.

4.06 MAX OR (2) 3.30 DIA [.160 MAX OR (2).130 MAX]	[#16-#12] AWG	0.81 [.032]	42663-2
INSUL RANGE	WIRE SIZE	MATING TAB THK ±0.025 [.001]	PART NO

THIS DRAWING IS A CONTROLLED DOCUMENT.		DWN JR RUTH 2/15/94	TE Connectivity													
DIMENSIONS: mm [INCHES]		CHK MS FEHER 2/15/94														
TOLERANCES UNLESS OTHERWISE SPECIFIED:		APVD J GILLESPIE 2/15/94	NAME RECEPTACLE, FASTIN-FASTON, 7.92 [.312] SERIES													
<table border="0"> <tr><td>0 PLC</td><td>± -</td></tr> <tr><td>1 PLC</td><td>± -</td></tr> <tr><td>2 PLC</td><td>± 0.38 [.015]</td></tr> <tr><td>3 PLC</td><td>± -</td></tr> <tr><td>4 PLC</td><td>± -</td></tr> <tr><td>ANGLES</td><td>± -</td></tr> </table>		0 PLC	± -	1 PLC	± -	2 PLC	± 0.38 [.015]	3 PLC	± -	4 PLC	± -	ANGLES	± -	PRODUCT SPEC -	RESTRICTED TO -	
0 PLC	± -															
1 PLC	± -															
2 PLC	± 0.38 [.015]															
3 PLC	± -															
4 PLC	± -															
ANGLES	± -															
MATERIAL BRASS	FINISH TIN	APPLICATION SPEC -	SIZE A3	CAGE CODE 00779												
		WEIGHT -	DRAWING NO C-42663													
CUSTOMER DRAWING			SCALE 4:1	SHEET 1 of 1												
			REV J													