

REVISONS		DATE	BY	APPV
T	REV PER ECO-15-016251	13NOV15	KG	CD

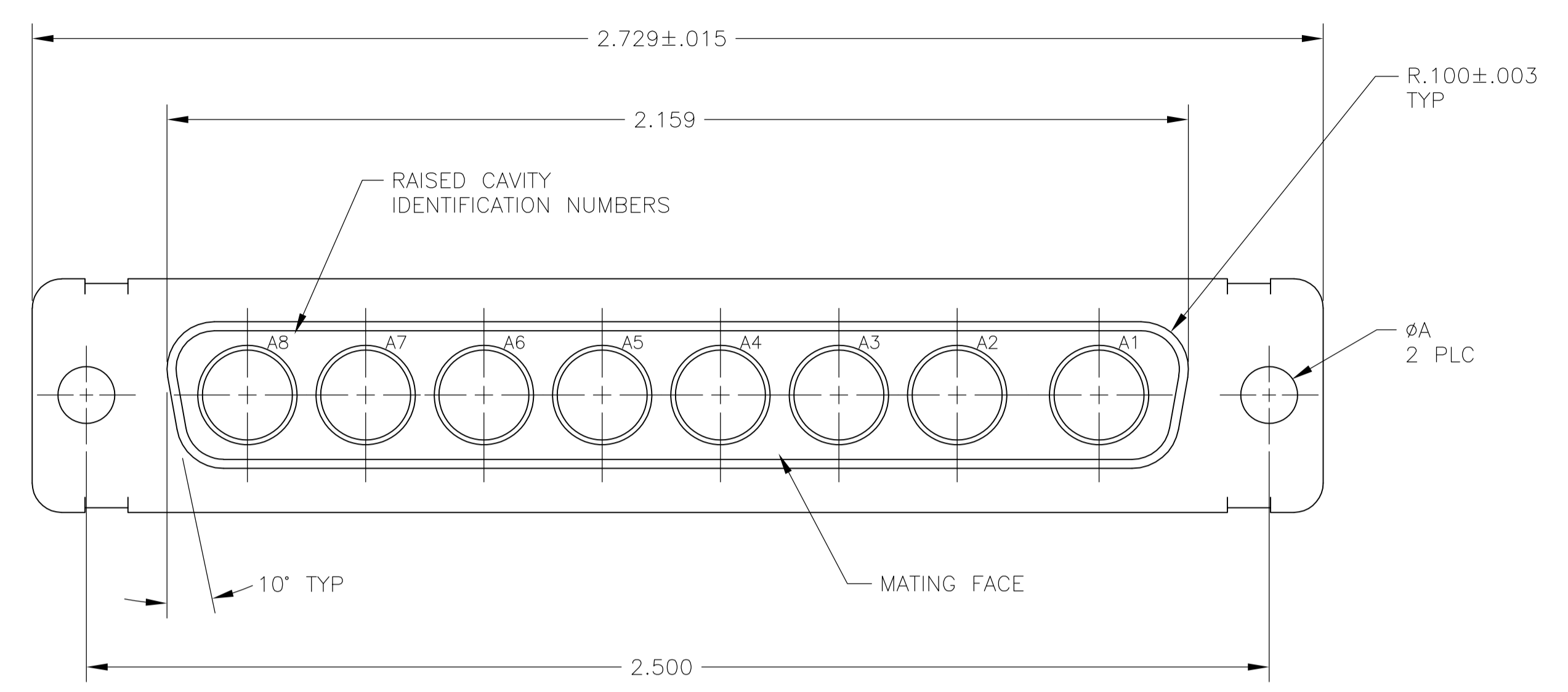

- THIS CONNECTOR ACCEPTS (8) POWER 8, OR COAX SOCKET CONTACTS IN POSITIONS A1 THRU A8, PURCHASED SEPARATELY.
- STEEL PER ASTM-A-109.
- BRASS PER MIL-C-50 AND ASTM-B-36 UNS NO. C26000.
- FINISH: CADMIUM PLATED PER QQ-P-416.
- GOLD PLATED PER ASTM-B-488 TYPE 3, CODE C, CLASS 1.25 OVER COPPER PER MIL-C-14550, CLASS IV.
- FINISH: TIN PER ASTM-B-545 .000400 MIN THK OVER COPPER PER AMS2418 .000050 MIN THK.
- FINISH: ZINC PLATED PER ASTM-B-633 .000200-.000400 THK WITH SUPPLEMENTARY CHROMATE (Cr3+).

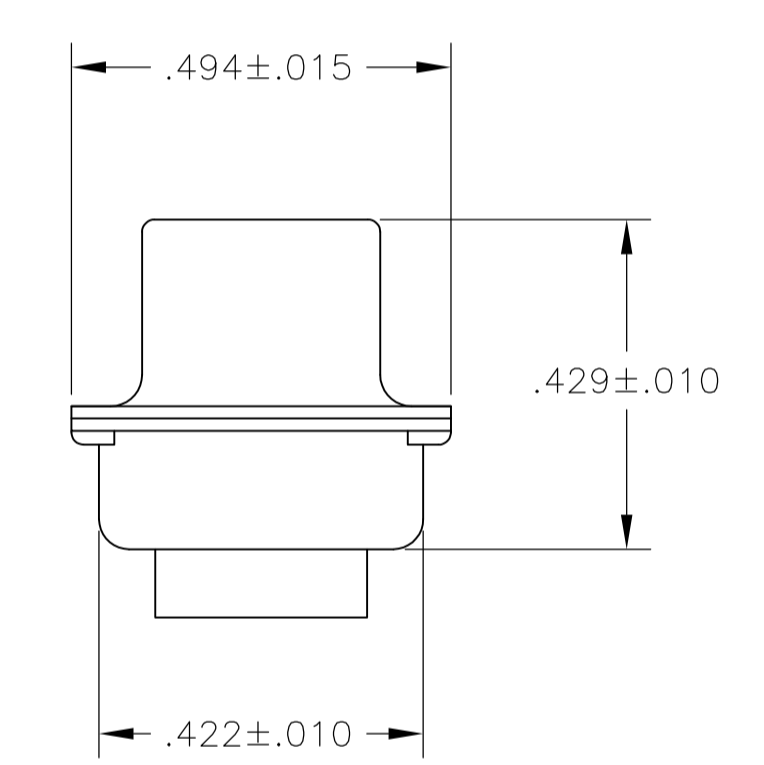
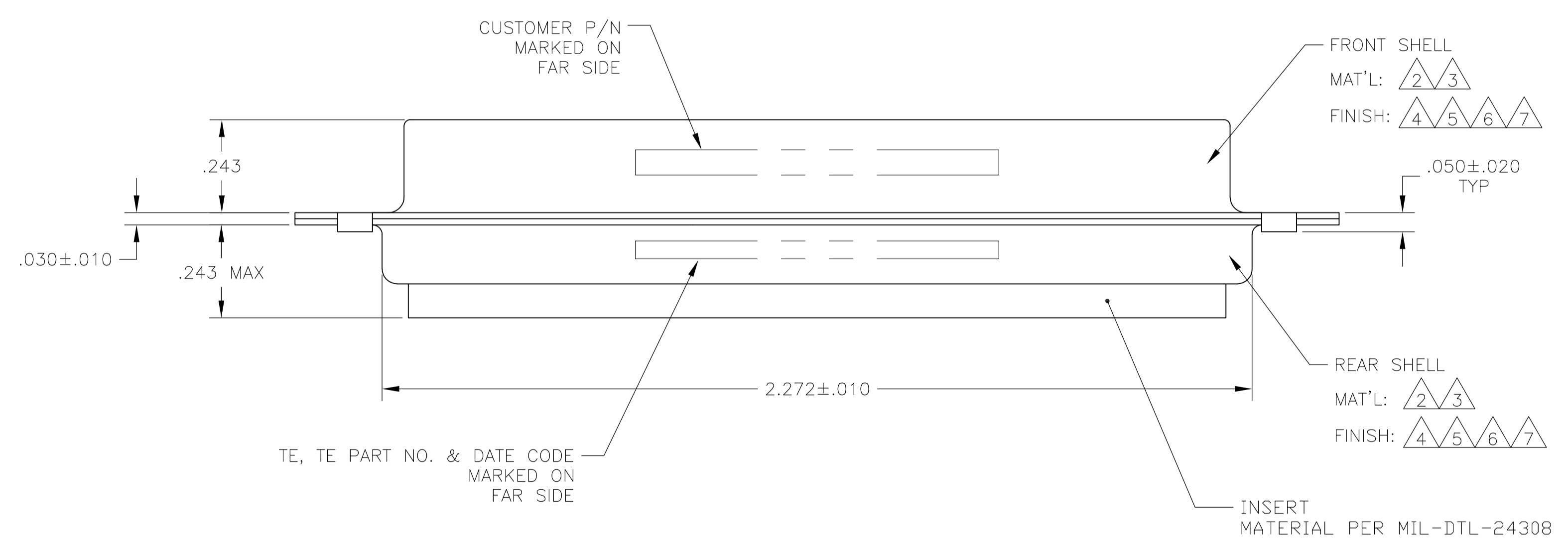

PRELIMINARY- NOT RELEASED FOR PRODUCTION

REMARKS	ØA	CUSTOMER PART NO.	PART NO.
	.120	-	5-445730-5
	.120	-	5-445730-1
	.120	13508255	445730-8
	.120	ST81D284-002	445730-7
	.120	B010942-0042	445730-6
	.120	-	445730-5
	.154	311P405-15S-B-15	445730-4
	.120	311P405-15S-B-12	445730-3
	.120	2037AS246-01,00779,3003	445730-2
	.120	-	445730-1

THIS DRAWING IS A CONTROLLED DOCUMENT. **STE** TE Connectivity

DIMENSIONS: INCHES 	TOLERANCES UNLESS OTHERWISE SPECIFIED: 0 PLC ± - 1 PLC ± - 2 PLC ± - 3 PLC ± .005 4 PLC ± - ANGLES ± 0°30'	DRAWING NO: A100779 CUSTOMER DRAWING	DATE: 29-NOV-88 CHK: T. SHUEY DATE: 01-DEC-88 APPV: A. EMADI DATE: 01-DEC-88	NAME: RECEPTACLE ASSEMBLY AMPLIMITE 8C8 SIZE 4, SERIES 109, COAX	RESTRICTED TO: -
MATERIAL: -	FINISH: -	WEIGHT: -	SCALE: 4:1	SHEET 1 OF 1	REV T