

THIS DRAWING IS UNPUBLISHED. RELEASED FOR PUBLICATION  
 © COPYRIGHT - By - ALL RIGHTS RESERVED.

LOC		DIST		REVISIONS			
P	LTR	DESCRIPTION		DATE	DWN	APVD	
AF	50	G1	REVISED PER ECR-13-019898		24DEC2013	GRZ	JL

- 1 CONTINUOUS STRIP ON REELS WITH TERMINALS LOCATED ON  $8.38 \pm 0.08$   $[\ .330 \pm .003 ]$  CENTERS.
- 2 SLOT ACCEPTS 0.36-0.51mm  $[\ #27-\#24 ]$  AWG COPPER MAGNET WIRE. TWO WIRES OF THE SAME SIZE MAX PER SLOT
- 3 IDENTIFICATION NUMBER 10 FOR THE MAGNET WIRE SLOT SIZE
- 4 0.25 $[\ .010 ]$  MAX CARRIER CUT-OFF TABS

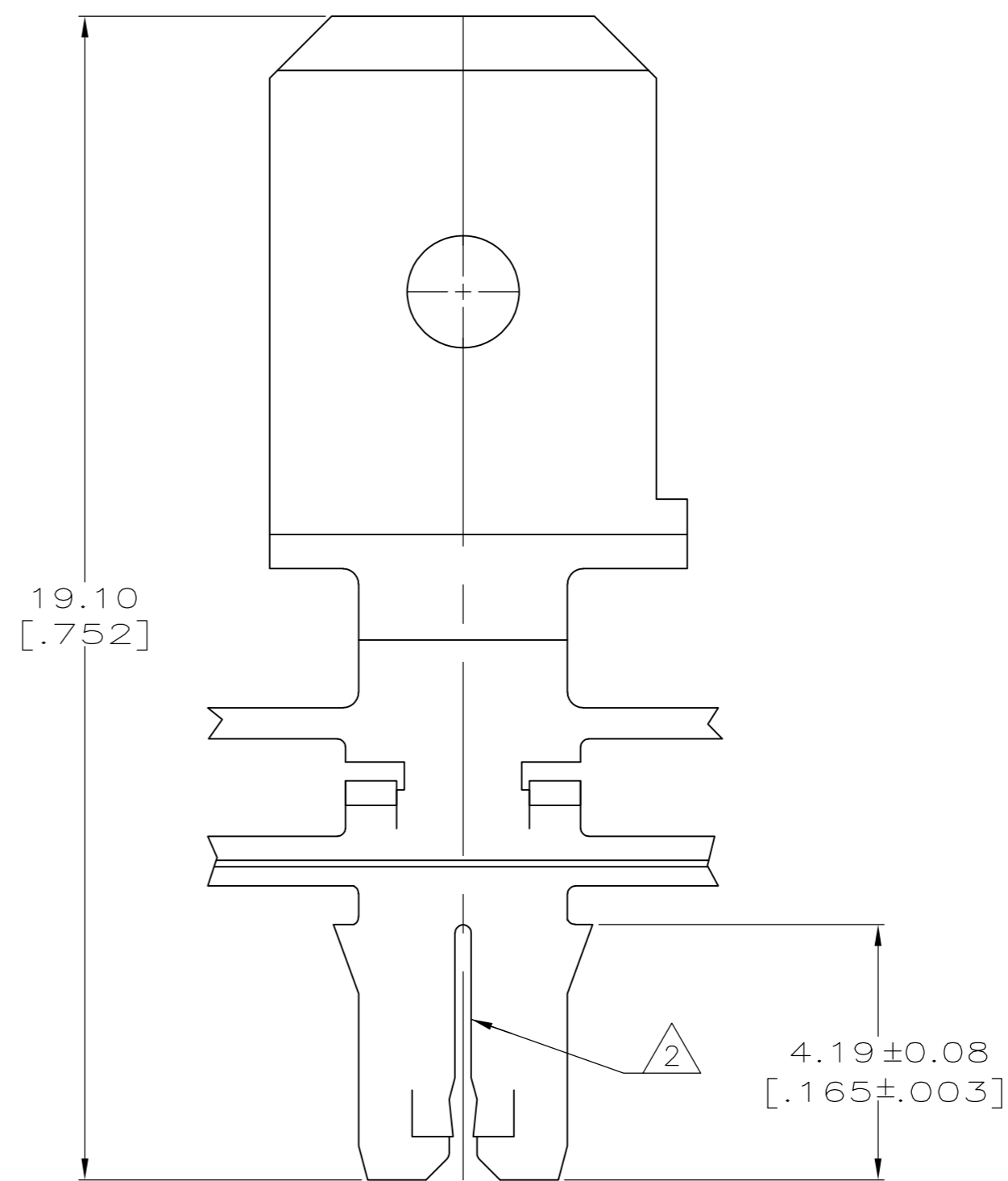
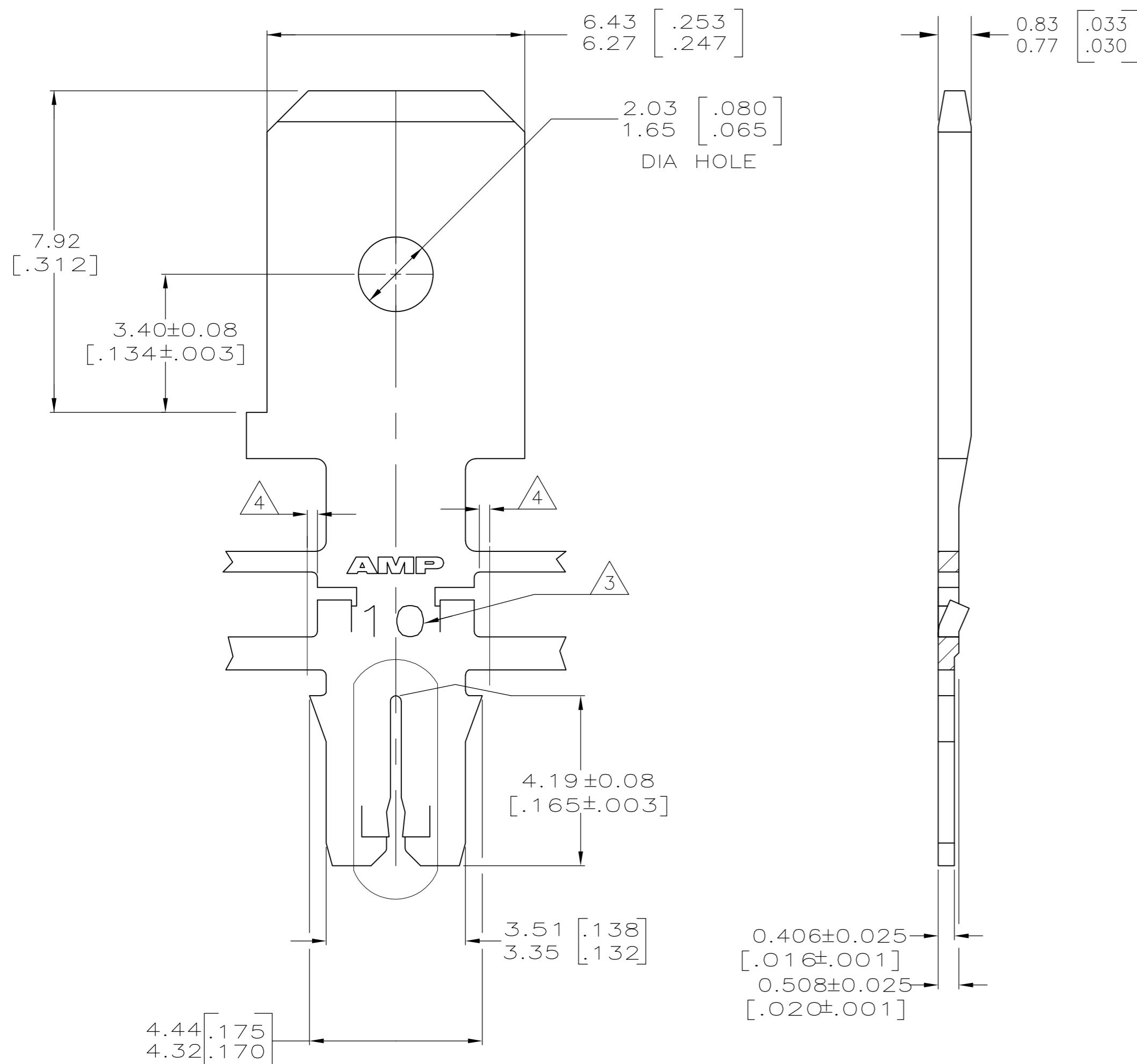

OBSELETE	082 PRE-MILLED BRASS	5	63718-2
	<del>4M PRE-MILLED BRASS</del>		<del>63718-1</del>
MATERIAL		PART NUMBER	

THIS DRAWING IS A CONTROLLED DOCUMENT.		DWN	L.A.MAYER	9-27-93	<b>TE</b> TE Connectivity		
DIMENSIONS: INCHES		CHK	M.S. FEHER	9-27-93			
TOLERANCES UNLESS OTHERWISE SPECIFIED:		APVD	A.HUNT III	9-27-93	NAME		
0 PLC	± -	PRODUCT SPEC		TAB, 6.35 $[\ .250 ]$ FASTON™			
1 PLC	± -	APPLICATION SPEC		MAG-MATE™ Slim Line			
2 PLC	± 0.13 $[\ .005 ]$	108-1484		SIZE	CAGE CODE	DRAWING NO	RESTRICTED TO
3 PLC	± -	114-2140		A2	00779	C=63718	-
4 PLC	± -	FINISH		WEIGHT	SCALE		SHEET
ANGLES	± -	0.002032 $[\ .000080 ]$		-	10:1		1 of 1
MATERIAL	SEE TABLE	MIN TIN PLATE		CUSTOMER DRAWING		REV G1	