

THIS DRAWING IS UNPUBLISHED. RELEASED FOR PUBLICATION, 19 .  
 © COPYRIGHT 19 BY AMP INCORPORATED. ALL RIGHTS RESERVED.

LOC	DIST	REVISIONS			
P	LTR	DESCRIPTION	DATE	DWN	APVD
AF	50	A	RELEASE PER 0L10-0104-96	23/SEP/96	PF PD

- 1 CONTINUOUS STRIP ON REELS.
- 2 WIRE SIZES [#26-#22] AWG.
- 3 MATES WITH 0.51±0.025 [.020±.001] THK TAB.

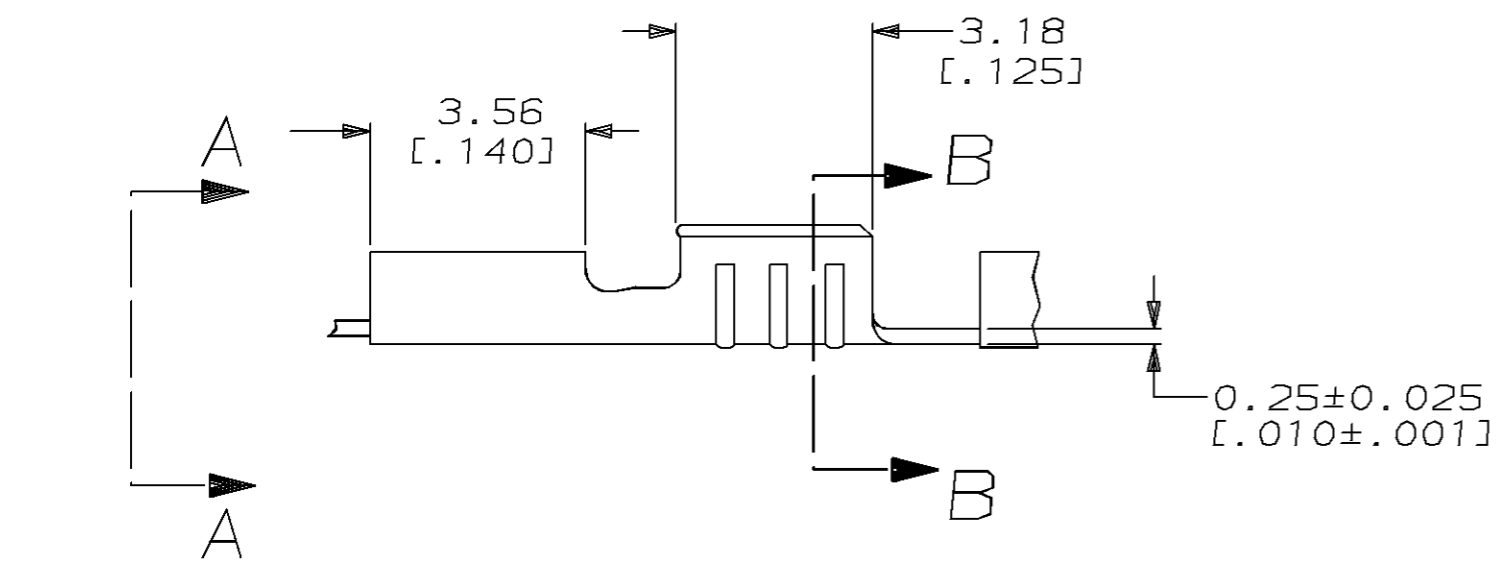
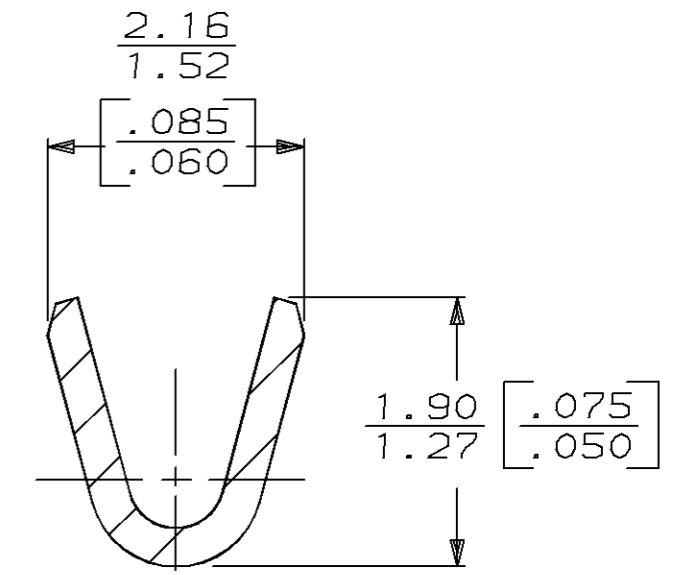
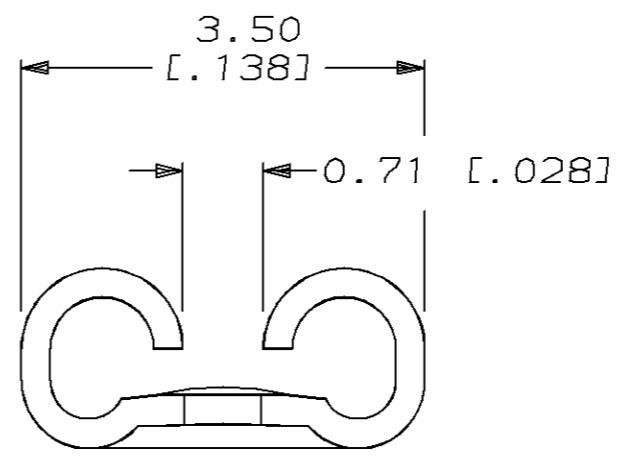
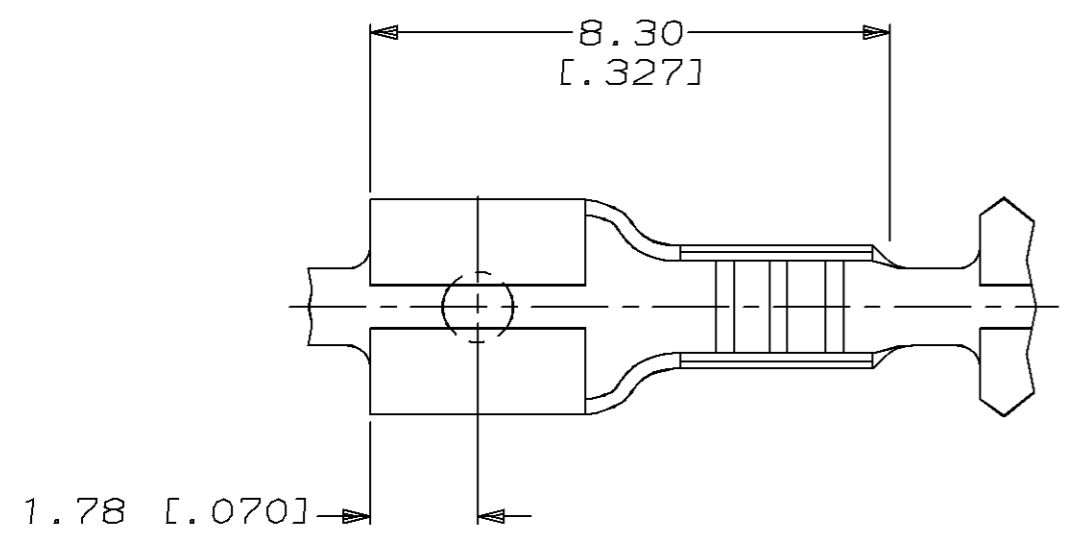

VIEW A-A

SECTION B-B

63924-1  
PART NO.

3.96 [.156]	F	1.40 [.055]	0.69 [.027]	0.71 [.028]	0.79 [.031]	±.051 [±.002]	HEIGHT	WIRE
STRIP LENGTH ±0.38 ± [.015]	TYPE	WIDTH	[#26]	[#24]	[#22] OR TWO [26]			
WIRE BARREL CRIMP								

THIS DRAWING IS A CONTROLLED DOCUMENT.

DIMENSIONS: MM [INCHES]

TOLERANCES UNLESS OTHERWISE SPECIFIED:

0 PLC	±-
1 PLC	±-
2 PLC	±0.25 [.010]
3 PLC	±-
4 PLC	±-
ANGLES	±1°

FINISH: -

MATERIAL: H04 PHOS BRONZE

DWN: JR RUTH 7/26/96  
 CHK: MS FEHER 7/26/96  
 APVD: P DESANTIS 7/26/96  
 PRODUCT SPEC: -  
 APPLICATION SPEC: 114-2036  
 WEIGHT: -  
 CUSTOMER DRAWING

**AMP** AMP Incorporated  
Harrisburg, PA 17105-3608

RECEPTACLE, FASTON, 2.79 [.110] SERIES

SIZE: A3 CAGE CODE: 00779 DRAWING NO: C-63924

SCALE: 8:1 SHEET: 1 OF 1 REV: A