

THIS DRAWING IS UNPUBLISHED.

RELEASED FOR PUBLICATION

20

© COPYRIGHT 20 BY -

ALL RIGHTS RESERVED.

REVISIONS

P	LTR	DESCRIPTION	DATE	DWN	APVD
	A	INITIAL	25MAR2015	DW	CW
	B	ECR-15-018270	08DEC2015	DW	CW
	C	ECR-21-111798	29SEP2021	WQR	CW

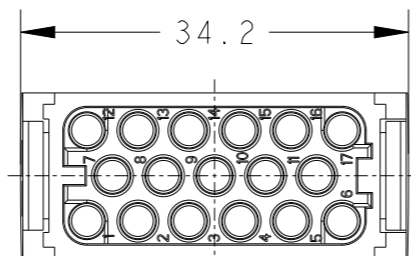
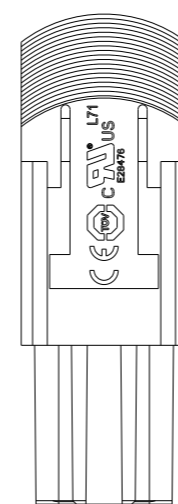
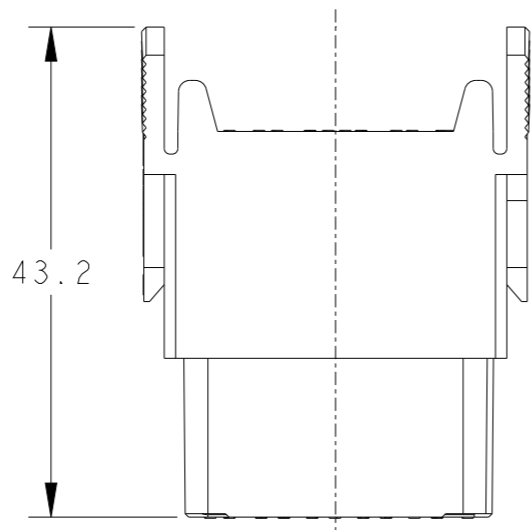
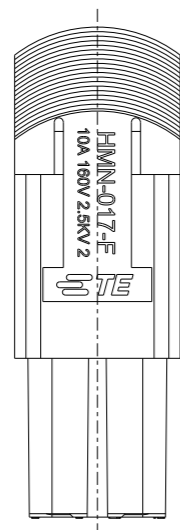
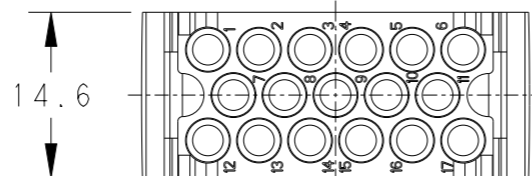
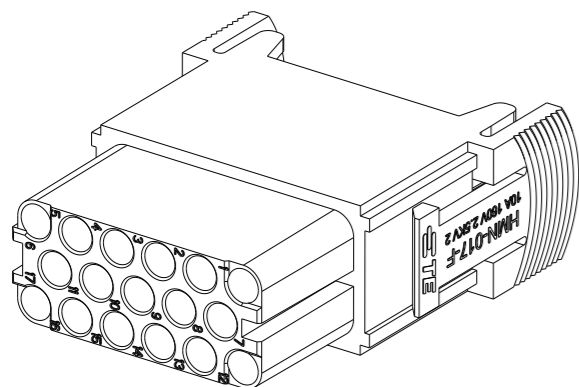

NOTES:

- TECHNICAL CHARACTERISTICS:
 INSULATION MATERIAL: PC
 RATED VOLTAGE: 160V
 RATED CURRENT: 10A
 INSULATION RESISTANCE: $\geq 400M\Omega$
 RATED IMPULSE VOLTAGE: 2.5KV
 POLLUTION DEGREE: 2
 FLAMMABILITY: UL94V-0
 MATING CYCLES: 500 CYCLES
 OPERATION TEMPERATURE: $-40\sim+125^{\circ}C$
 WIRE RANGE: $0.14\sim 2.5\text{ mm}^2$ (26~14 AWG)
 CONTACT TYPE: CRIMP CONTACT
- CONTACT NEED TO BE ORDERED SEPARATELY.
 (ORDER No. REFER TO DRAWING: T20200X20XX000)

注释:

- 技术参数:
 绝缘材料: PC
 额定电压: 160V
 额定电流: 10A
 绝缘电阻: $\geq 400M\Omega$
 额定脉冲电压: 2.5KV
 污染等级: 2
 阻燃等级: UL94V-0
 插拔次数: 500次
 工作温度: $-40\sim+125^{\circ}C$
 接线范围: $0.14\sim 2.5\text{ mm}^2$ (26~14 AWG)
 接线类型: 冷压接
- 端子需要单独订购.
 (订货号参考图面: T20200X20XX000)

HMN-017-F	T2111172201-000
DESCRIPTION	PART NUMBER



THIS DRAWING IS A CONTROLLED DOCUMENT.		DWN	25MAR2015	NAME	HMN-017-F
DIMENSIONS:		CHK	25MAR2015		
mm		APVD	25MAR2015		
TOLERANCES UNLESS OTHERWISE SPECIFIED:		PRODUCT SPEC	108-137062		
1 PLC \pm		APPLICATION SPEC	114-137062	SIZE	A3
2 PLC \pm		MATERIAL	-	CAGE CODE	00779
3 PLC \pm		FINISH	-	DRAWING NO	T2111172201000
4 PLC \pm				RESTRICTED TO	-
ANGLES \pm				WEIGHT	-
MATERIAL				SCALE	3:2
-				SHEET	1 OF 1
-				REV	C
		Customer Drawing			