

P	LTR	DESCRIPTION	DATE	DWN	APVD
A		INITIAL RELEASE	14AUG2020	DW	CW
A1		ECR-20-013971	25MAR2021	DW	CW
B		ECR-21-111798	07OCT2021	WOR	CW

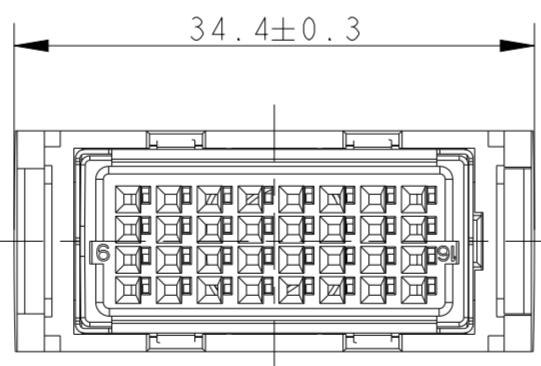

NOTES:
 1. TECHNICAL CHARACTERISTICS:
 INSULATION 1 MATERIAL: PC,GREY
 INSULATION 2 MATERIAL: PBT,NATURAL
 SHELL MATERIAL: COPPER
 RATED VOLTAGE: 32 V
 RATED CURRENT: 2.2 A
 INSULATION RESISTANCE: >=100MΩ
 RATED IMPULSE VOLTAGE: 0.8 KV
 POLLUTION DEGREE: 3
 FLAMMABILITY: UL94V-0
 MATING CYCLES: SEE TABLE 1
 TEMPERATURE RANGE: -40°C~+125°C
 WIRE RANGE: SEE TABLE 1
 CONTACT TYPE: CRIMP CONTACT
 2. CONTACT NEED TO BE ORDERED SEPARATELY.
 (ORDER No. REFER TO DRAWING : SEE TABLE 1)

注释:
 1. 技术参数:
 绝缘1材料: PC,灰色
 绝缘2材料: PBT,本色
 壳体材料: 铜合金
 额定电压: 32 V
 额定电流: 2.2 A
 绝缘电阻: >=100MΩ
 额定脉冲电压: 0.8 KV
 污染等级: 3
 阻燃等级: UL94V-0
 插拔次数: 见表格1
 温度范围: -40°C~+125°C
 接线范围: 见表格1
 接线类型: 冷压接
 端子需要单独订购.
 (订货号参考图面: 见表格1)

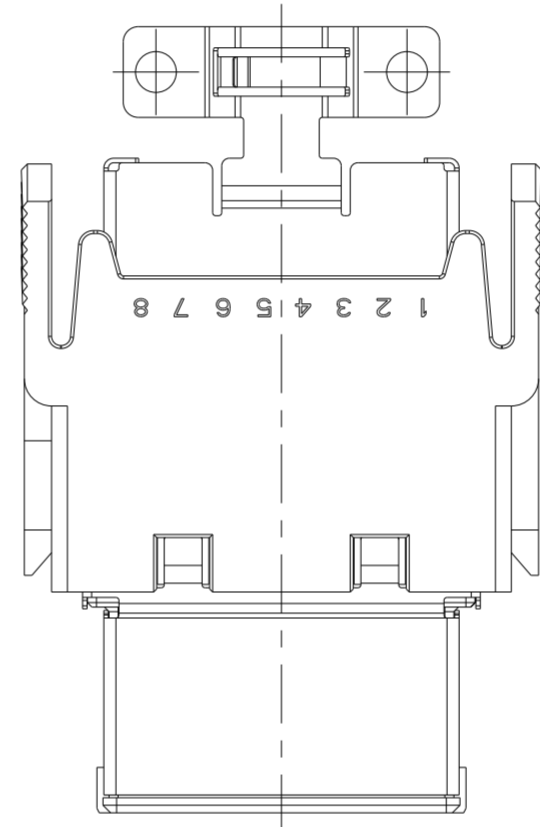
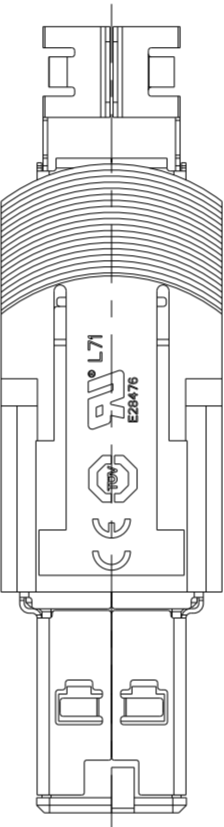
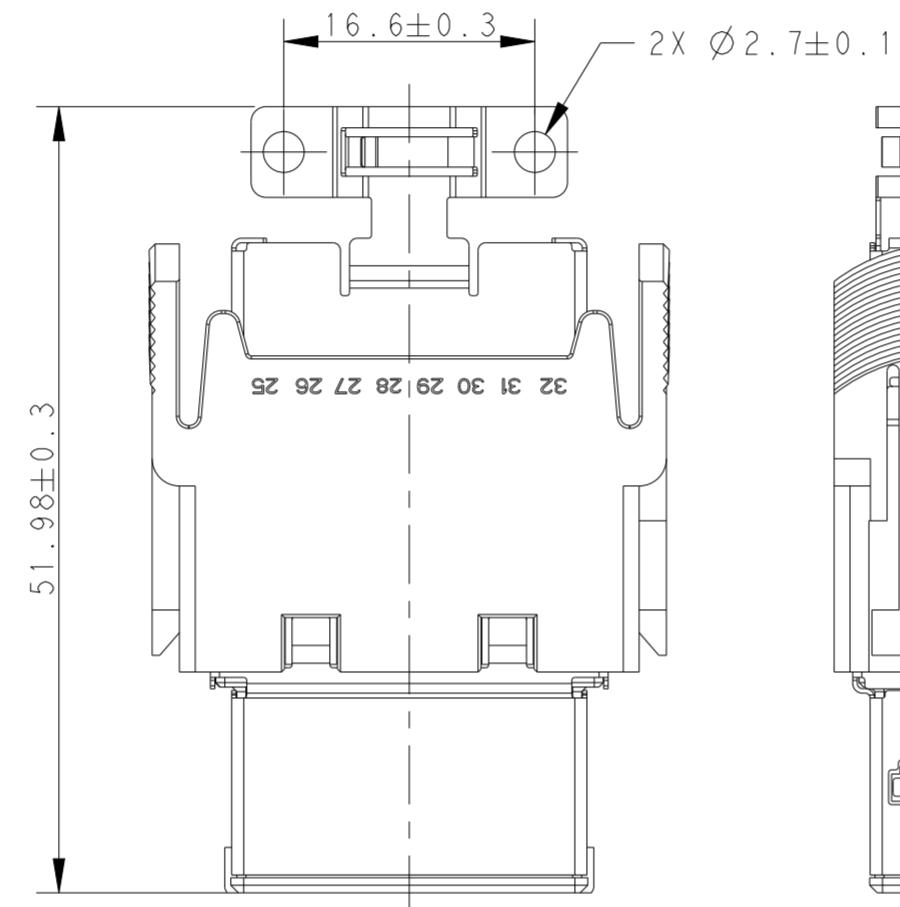
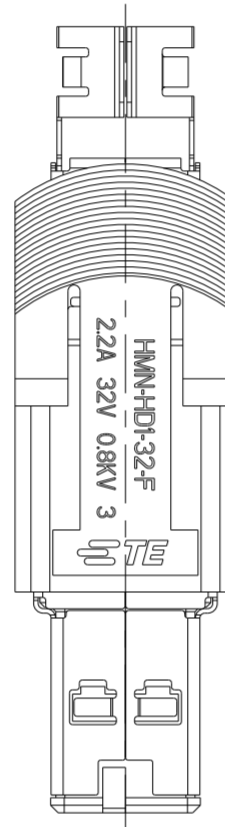
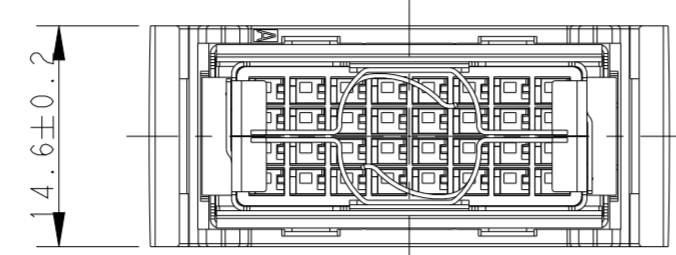
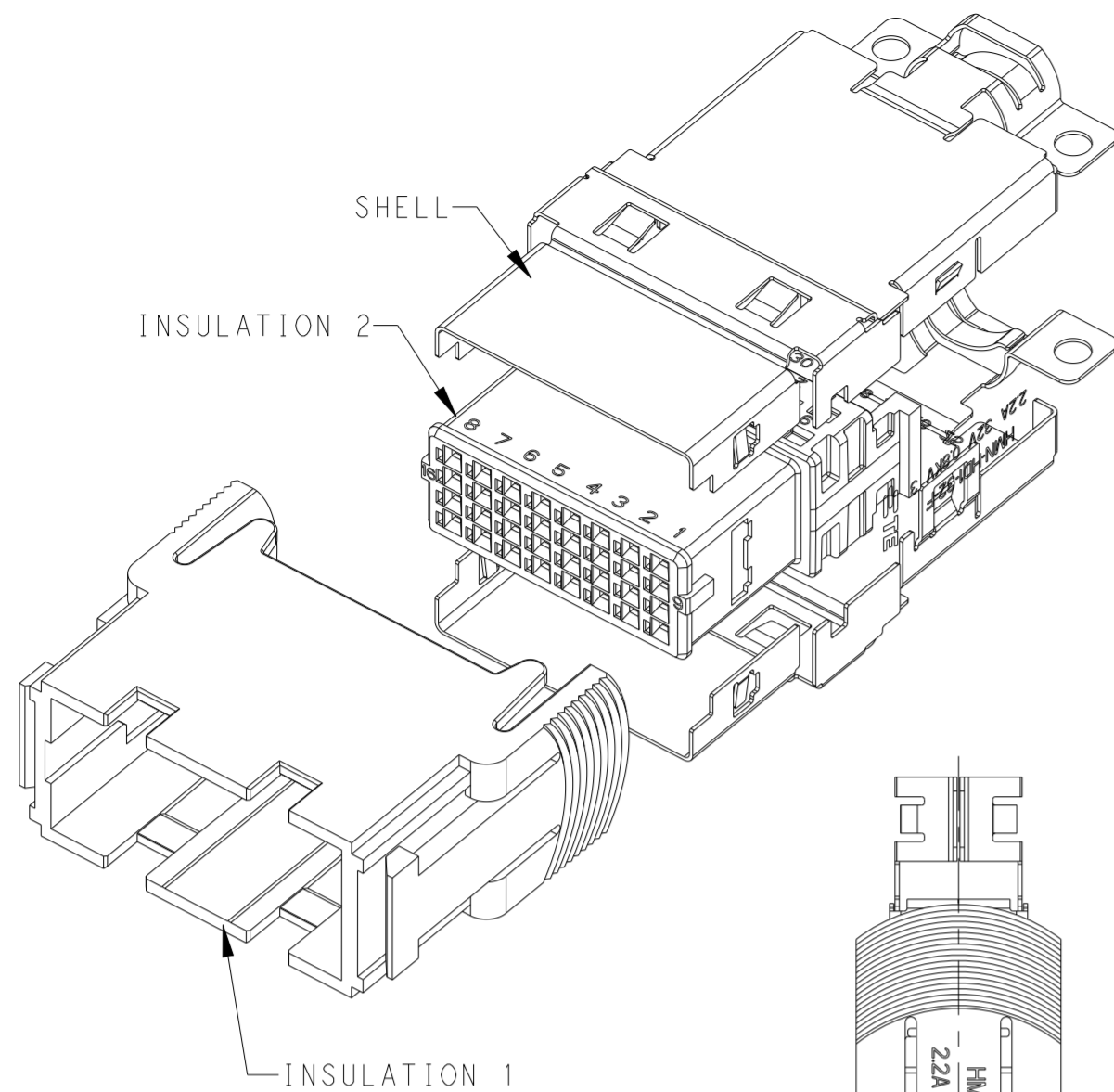
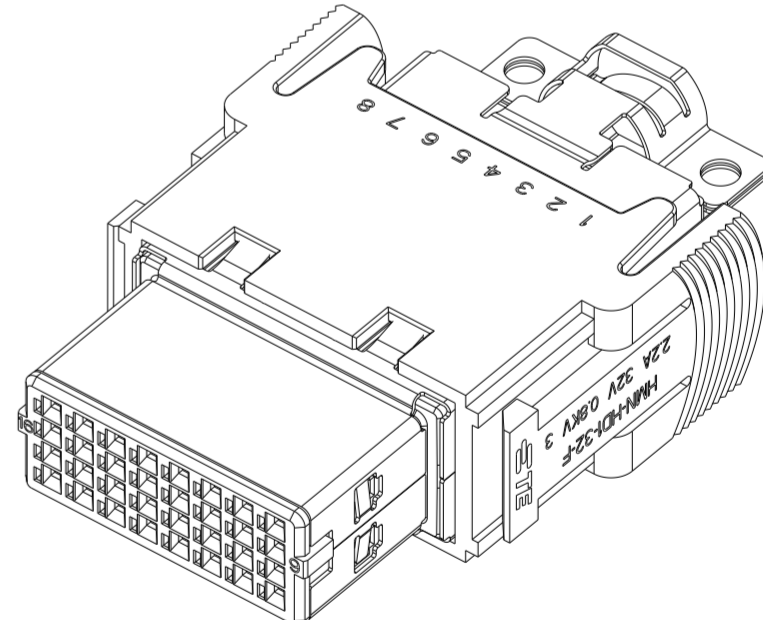

TABLE 1
表格 1

SIGNAL (32 POS) 信号 (32 POS)	1.08-1.6	AWG28-22, 0.08-0.3750mm	M	2316670-2	2316671-2	HDI RECEPTACLE CONTACT	500
	0.6-1.2	AWG30-28, 0.05-0.1050mm <td>S</td> <td>2316670-1</td> <td>2316671-1</td> <td></td> <td></td>	S	2316670-1	2316671-1		
HYBRID TYPE 混合类型	INSULATION RANGE (mm) 电缆绝缘外径范围 (mm)	WIRE RANGE 线规	SIZE 大小	REEL 卷	L/P 散件	DESCRIPTION 端子类型描述	MATING CYCLES 插拔次数
				PART NUMBER			

T2111322201-000		HMN-HD1-32-F		HMN-HD1-32-F FEMALE INSERT,8.45 HMN-HD1-32-F 母插,8.45													
PART NUMBER 料号		PART DESCRIPTION 描述															
THIS DRAWING IS A CONTROLLED DOCUMENT.		DWN DAVID WANG 06MAY2020															
DIMENSIONS: mm		CHK GINO YAO 06MAY2020															
TOLERANCES UNLESS OTHERWISE SPECIFIED:		APVD CHRIS WANG 06MAY2020															
<table border="0"> <tr><td>0 PLC</td><td>±</td></tr> <tr><td>1 PLC</td><td>±</td></tr> <tr><td>2 PLC</td><td>±</td></tr> <tr><td>3 PLC</td><td>±</td></tr> <tr><td>4 PLC</td><td>±</td></tr> <tr><td>ANGLES</td><td>±</td></tr> <tr><td>FINISH</td><td>±</td></tr> </table>		0 PLC	±			1 PLC	±	2 PLC	±	3 PLC	±	4 PLC	±	ANGLES	±	FINISH	±
0 PLC	±																
1 PLC	±																
2 PLC	±																
3 PLC	±																
4 PLC	±																
ANGLES	±																
FINISH	±																
MATERIAL -		PRODUCT SPEC 108-137507		SIZE A2													
		APPLICATION SPEC 114-137507		CAGE CODE 00779													
		WEIGHT -		DRAWING NO C-T2111322201000													
		CUSTOMER DRAWING		RESTRICTED TO -													
		SCALE 2:1		SHEET 1 OF 1													
				REV B													