

AMP INSERTION TOOL P/N 724797-1
 FOR ULTREX* 2MM PITCH CONNECTOR
 INSTRUCTION SHEET

IS - 224J
 Released 12-14-82

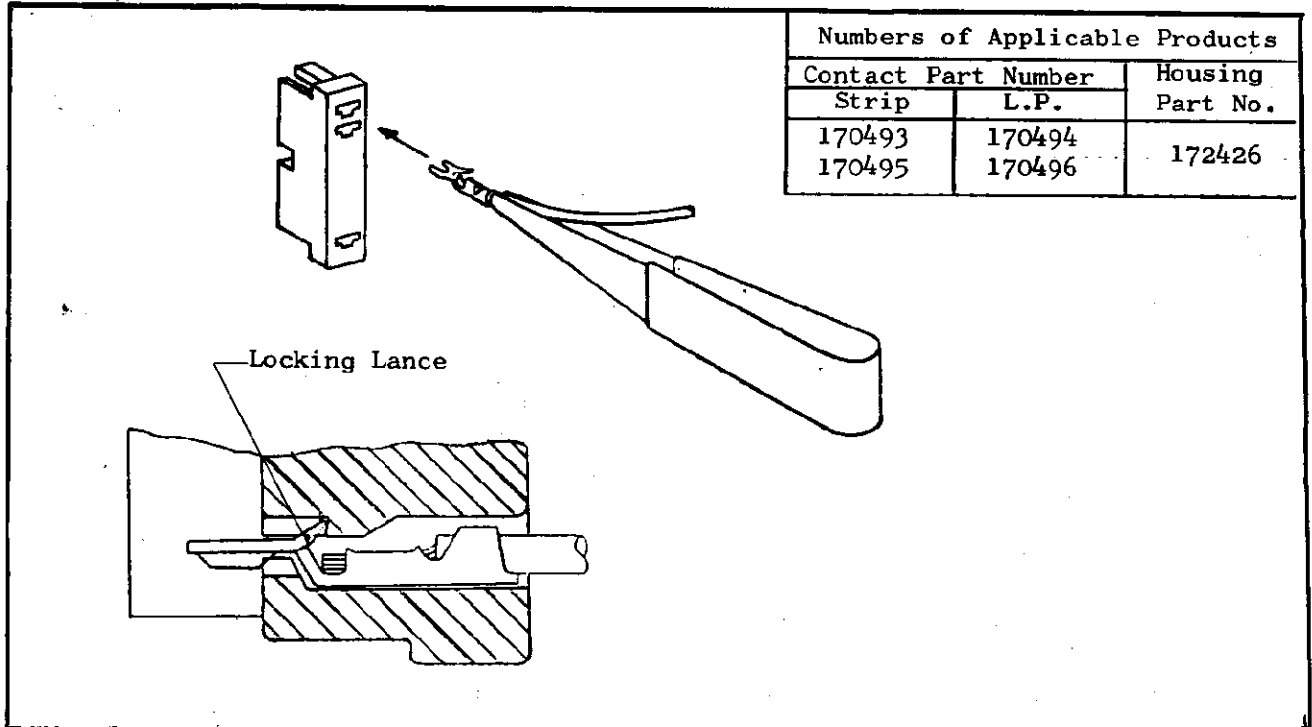

Fig. 1

1. INTRODUCTION:

AMP insertion tool P/N 724797-1 has been designed for inserting AMP ULTREX* contact into 2mm pitch connector housing, as shown in the table of Fig. 1. Read this instruction sheet carefully, before you start assembly.

2. INSERTION OF CONTACT:

This tool is basically similar to a set of pincers, having a proper shape for gripping and inserting the contact into housing cavity. Pinch the crimped wire at the portion next to the contact, and push in straight into housing, until the locking lance engages.

When insertion is finished, pull back the wire lightly to confirm if the locking lance engagement is alright.

It is recommended that you pinch the wire at the portion nearest to the contact, so that gripping of contact is firm and stable, especially when gripping thin wire that is applied on.

3. MAINTENANCE:

This tool is specifically designed for inserting application of the products shown in Fig. 1.

When not in use, store in dry, clean place, with special care not to damage the tip ends. Do not use the tool for the purpose other than stated.