



**NOTE**

All numerical values are in metric units. Dimensions are in millimeters. Figures and illustrations are for identification only and are not drawn to scale.

## 1. INTRODUCTION

This specification covers the requirements for application of receptacle and tab battery terminals that are for direct to PCB insertion. The solder legs of the terminals for direct to PCB insertion are designed to have an interference fit with the PCB slots. Please see Customer Drawings for recommended PCB layouts.

The terminals are available in strip form for inserting with semi-automatic or fully-automatic powered machines, and in loose-piece for inserting terminals to the PCB with manual or semi-automatic insertion equipment.

When corresponding with TE Connectivity Personnel, use the terminology provided in this specification to facilitate your inquiries for information. Basic terms and features of this product are provided in Figure 1.

**PCB Receptacle**

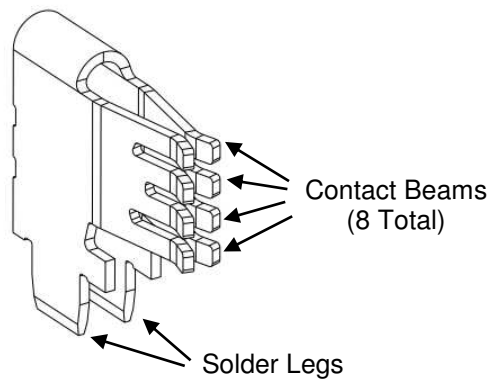

**PCB Tab**

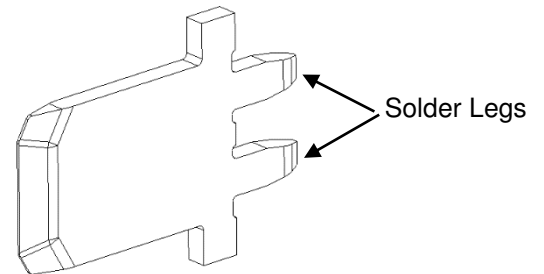
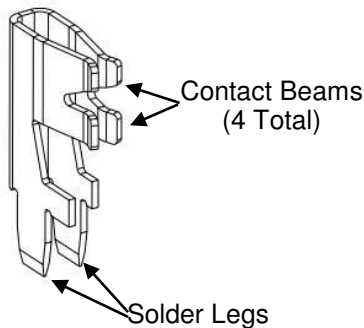
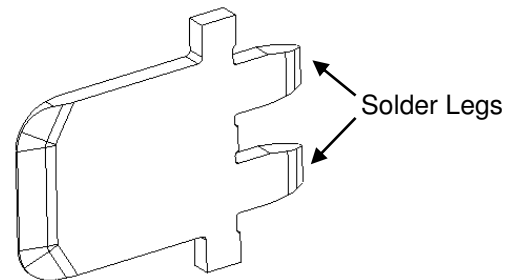

**Figure 1**

## 2. REFERENCE MATERIAL

### 2.1. Revision Summary

- Minor formatting corrections
- Added caution notes to start of Section 3

## 2.2. Customer Assistance

Product Code J975 is representative of Battery Receptacle terminals, and Product Code J976 is representative of Battery Tab terminals. Use of these numbers will identify the product line and help you to obtain product and tooling information when visiting [www.te.com](http://www.te.com) or calling the number at the bottom of page 1.

## 2.3. Drawings

Customer drawings for product part numbers will be available from [www.te.com](http://www.te.com). Information contained in the customer drawing takes priority.

## 2.4. Specifications

The Product Specification is listed below.

108-160280 Battery Terminals: Direct to PCB

## 2.5. Instructional Material

Instruction sheets (408-series) provide product assembly instructions or tooling setup and operation procedures and customer manuals (409-series) provide machine setup and operating procedures. Instructional material that pertain to this product are:

- No instructional material currently.

## 3. REQUIREMENTS



*Part is lubricated, and lubricant may be present on entire part surface. Avoid contact with terminal contact zone during handling to avoid removing lubricant from part (please see TE customer drawings for details).*



*Terminals are suitable for wave soldering. Contact TE Product Engineering for reflow solder applications.*

### 3.1. Safety

Do not stack product shipping containers so high that the containers buckle or deform.

### 3.2. Storage

#### A. Ultraviolet Light

Prolonged exposure to ultraviolet light may deteriorate the chemical composition used in the product material.

#### B. Reel Storage

When using reeled terminals, store coil wound reels horizontally and traverse wound reels vertically.

#### C. Shelf Life

The product should remain in the shipping containers until ready for use to prevent deformation to components. The product should be used on a first in, first out basis to avoid storage contamination that could adversely affect performance.

### D. Chemical Exposure

Do not store product near any chemical listed below as they may cause stress corrosion cracking in the material.

Alkalies	Ammonia	Citrates	Phosphates	Citrates	Sulfur Compounds
Amines	Carbonates	Nitrites	Sulfur Nitrites		Tartrates



**NOTE**

Where the above environmental conditions exist, phosphor-bronze terminals are recommended instead of brass.

### 3.3. Terminal to PCB Insertion

For the receptacle terminals, it is important for the insertion equipment to only press on the top surface of the receptacles in line with the solder legs (please see Figure 2):

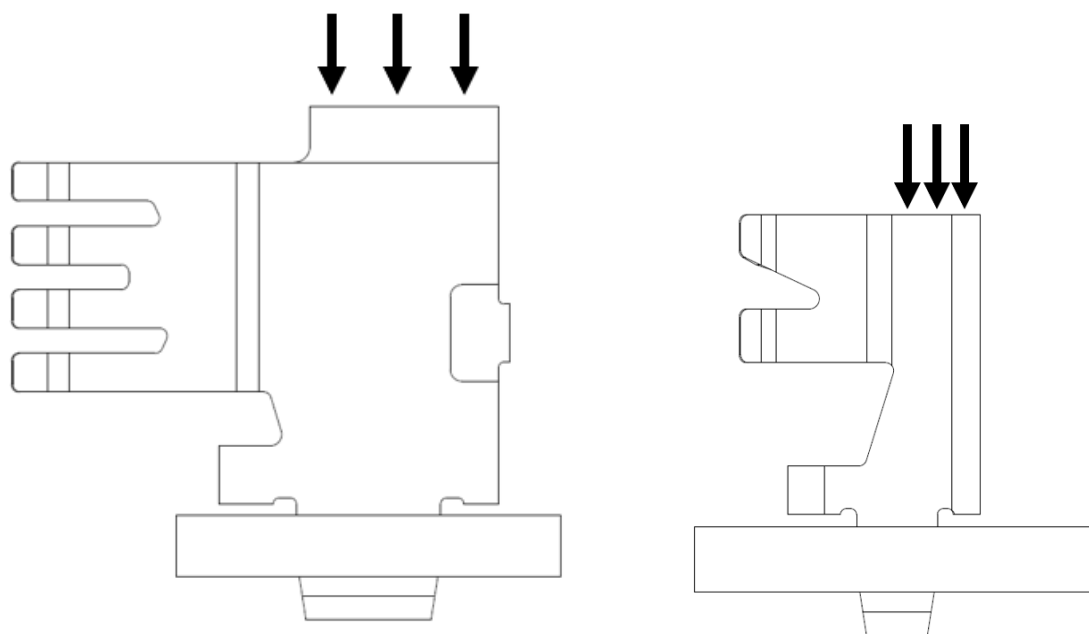

Figure 2

For the tab terminals, it is important for the insertion equipment to only press on the shoulders of the tabs (please see Figure 3):

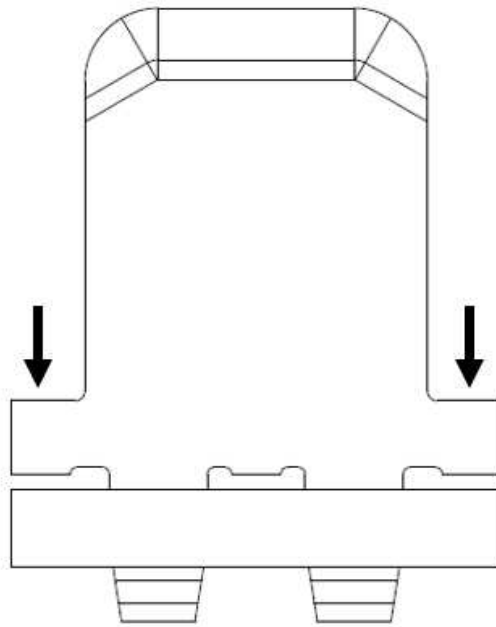

Figure 3

### 3.4. Receptacle Orientation

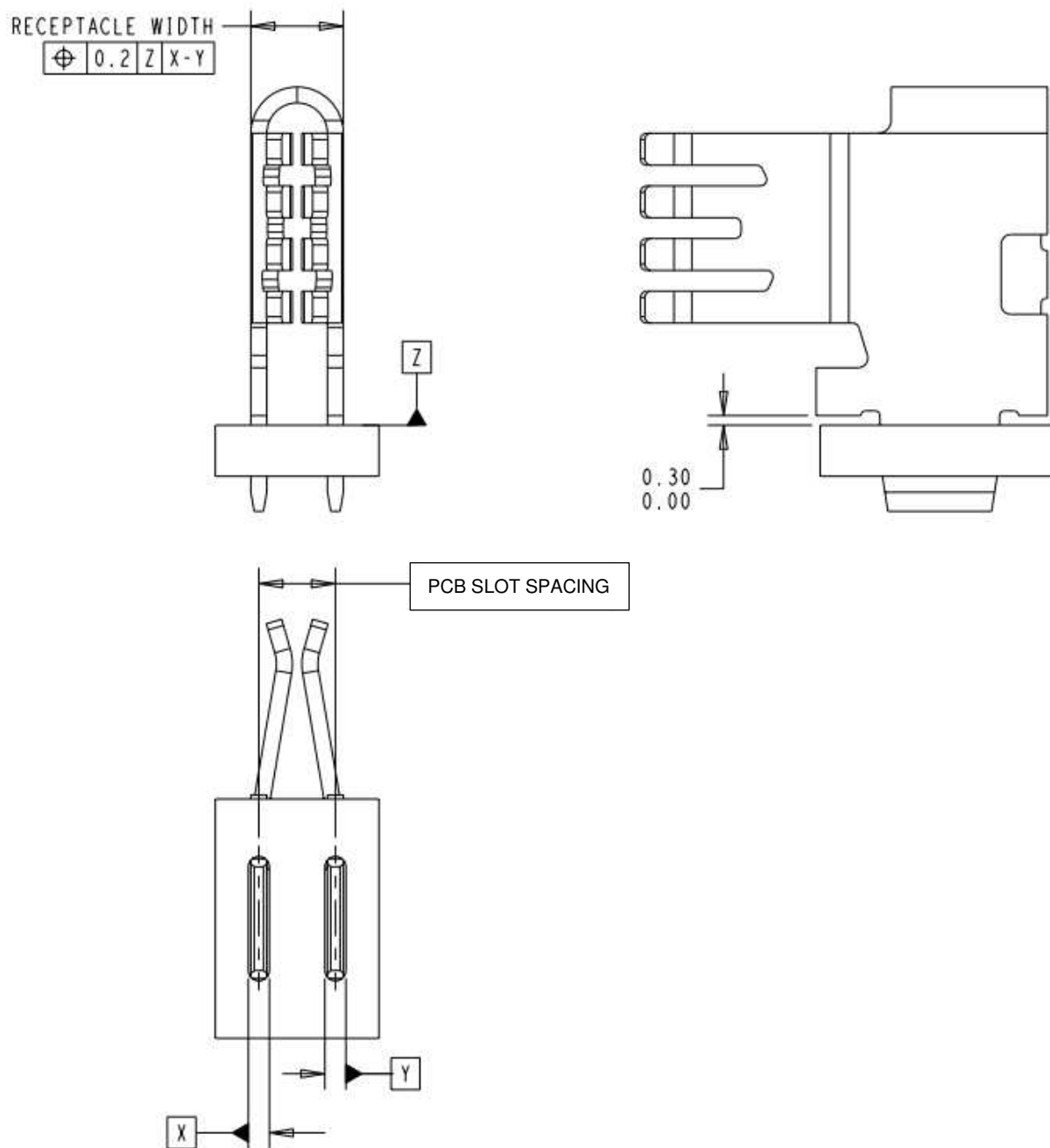

Figure 4

### 3.5. Tab Orientation

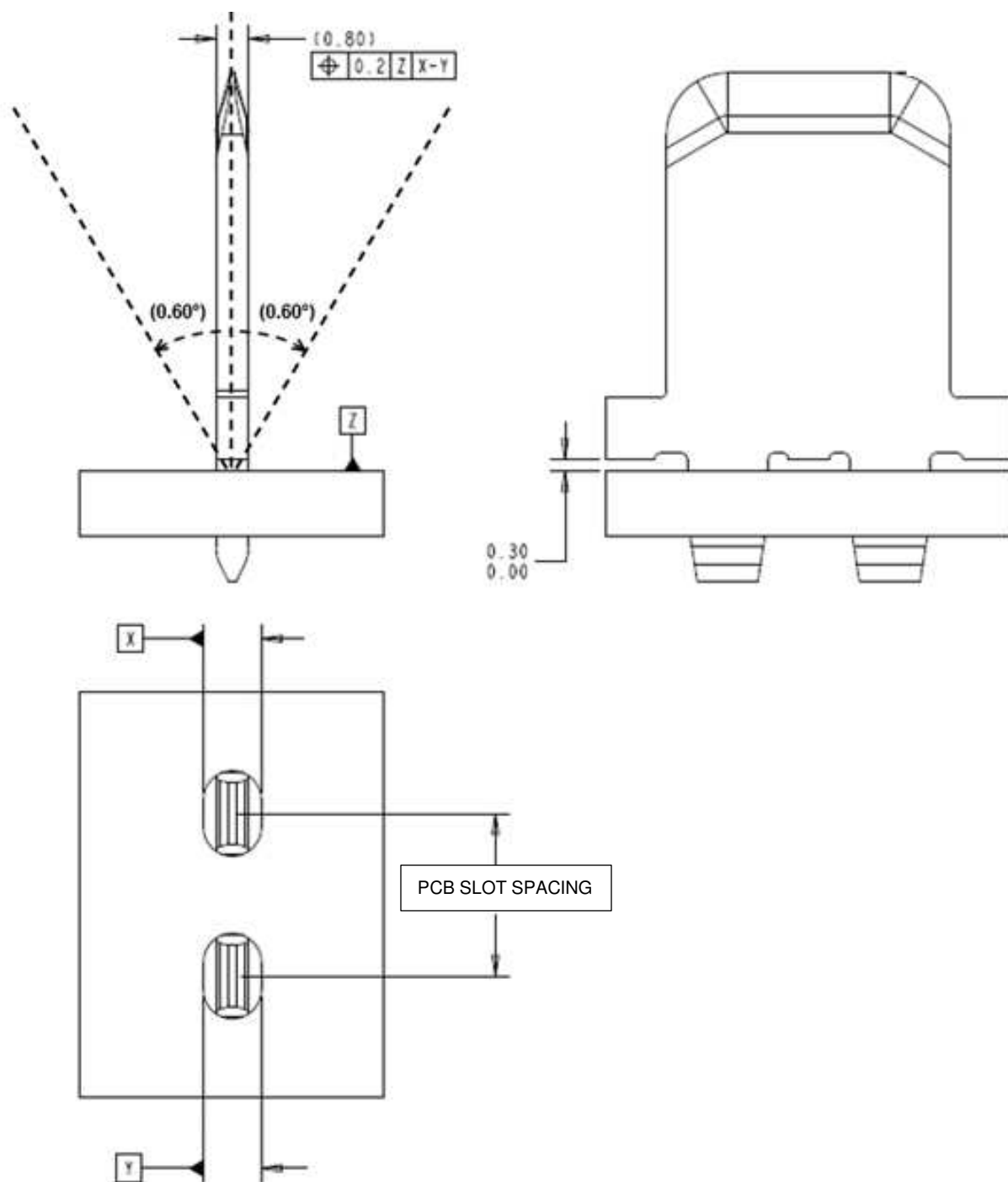

Figure 5