



---

**Power Key (PK) 5.0 W2B Product Specification**

---

**1. SCOPE**

1.1. Content

This specification covers performance, tests and quality requirements for the TE Connectivity (TE) Power Key(PK) 5.0 Connector System. The PK 5.0 product is a wire-to-board and mass terminated using insulation displacement or crimp termination technology on 5.8mm centerlines. The GIC5.8 connector system is available in 2-6 positions. It is designed to be terminated to 24 AWG to 16 AWG wire. The PK 5.0 product can meet glow wire test required by IEC 60335-1.

1.2. Qualification

When tests are performed on the subject product line, procedures specified in Figure 2 shall be used. All inspections shall be performed using the applicable inspection plan and product drawing.

1.3. Qualification Test Results

Successful qualification testing on the regular PK connector is 501-78274.

Successful qualification testing on the high current rating product line was completed between Oct 2020. The Qualification Test Report number for this testing is 502-106589.

1.4. Revision Summary

Revisions to this specification include:

- Rev F2 – Add high current rating version

**2. APPLICABLE DOCUMENTS AND FORMS**

The following documents form a part of this specification to the extent specified herein. Unless otherwise specified, the latest edition of the document applies. In the event of conflict between the requirements of this specification and the product drawing, the product drawing shall take precedence. In the event of conflict between the requirements of this specification and the referenced documents, this specification shall take precedence.

2.1. TE Connectivity Specifications

<a href="#">114-5292</a>	Application Specification
<a href="#">501-78274</a>	Qualification Test Report
<a href="#">502-106589</a>	Qualification Test Report

2.2. Commercial Standards and Specifications

EIA-364	Electrical Connector/Socket Test Procedures Including Environmental Classifications
---------	-------------------------------------------------------------------------------------

2.3. Reference Documents

<a href="#">102-950</a>	Qualification of Separable Interface Connectors
<a href="#">109-1</a>	General Requirements for Testing
<a href="#">109-197</a>	Test Specifications vs EIA and IEC Test Methods

**3. REQUIREMENTS**

3.1. Design and Construction

Product shall be of the design, construction, materials and physical dimensions specified on the applicable product drawing.

3.2. Ratings

- A. Voltage Rating: 300V AC (Except for the distance among round of PCB. When the distance among the round is 3mm or less, it is accepted 150VAC.)
- B. Current Rating: There are high current rating version and regular version for PK 5.0, For regular version see Figure 1 for applicable current carrying capability. High current rating version see Figure 2. Maximum rated current that can be carried by this product is limited by maximum operating temperature of the housings (105°C) and temperature rise of the housings (30°C). Variables to be considered for each application are: wire size, connector size, contact material, ambient temperature, and printed circuit board design.

Product Wire Size	Header except x-1376382-6, x-1376383-6, 1376384-6 and x-1376386-6				
Wire Size	16awg	18awg	20awg	22awg	24awg
Wire Length	29cm	25cm	20cm	16cm	14cm
2P	10A	8A	7A	5A	3A
3P	9A	7A	6A	4A	2A
4P	9A	7A	6A	4A	2A
6P	8A	6A	5A	3A	2A
4P(2row)	8A	6A	5A	3A	2A
6P(2row)	8A	6A	5A	2A	2A

**Figure 1 Regular PK 5.0**

Values are based on initial Temperature Rise versus Current Testing and are intended to be a guide in the selection of a connector family. All applications should be tested by the end user. The values listed are per circuit for fully loaded housings being 100% energized. Note: All combinations were not tested, and this chart contains interpolated and extrapolated values. Wire length follow EIA-364-70, If wire lengths used are less than those listed above, the current carrying ability of the system will be reduced due to less heat being conducted away from the connector. The customer should fully test all applications.

Product Wire Size	Header x-1376382-6, x-1376383-6, 1376384-6 and x-1376386-6			
Wire Size	16awg		18AWG	
Wire Length	29cm		25cm	
	Current rating with Derating*	Current rating**	Current rating with Derating*	Current rating**
2P	13A	15A	10.5A	12A
3P	11.5A	14A	10A	11.5A
4P (1 Row)	10A	12A	8.5A	10.5
4P (2 Row)	9A	10A	8A	8.5A

**Figure 2 High current PK 5.0**

\*Current rating with derating, follow IEC60512-5-2.

\*\* Current rating value was tested by temperature rise, see 3.4, follow EIA-364-70 method 1.

All the values are based on initial Temperature Rise versus Current Testing and are intended to be a guide in the selection of a connector family. All applications should be tested by the end user. The values listed are per circuit for fully loaded housings being 100% energized. Note: All combinations were not tested, and this chart contains interpolated and extrapolated values. Wire length follow EIA-364-70, If wire lengths used are less than those listed above, the current carrying ability of the system will be reduced due to less heat being conducted away from the connector. The customer should fully test all applications.

- C. Temperature Rating: -40°C to +105°C (The upper limit of the temperature includes the temperature rising by energized current.)

3.3. Performance Requirements and Test Description

The product should meet the electrical, mechanical and environmental performance requirements specified in Figure 2. All tests shall be performed at ambient environmental conditions otherwise specified.

3.4. Test Requirements and Procedure Summary

Test Description	Requirement	Procedure
Initial Examination of Product	Meets requirements of product drawing and Application Specification 114-5292.	EIA-364-18. Visual and dimensional inspection per product drawing.
Final Examination of Product	Meets visual requirements.	EIA-364-18. Visual examination.
<b>Electrical</b>		
Low Level Contact Resistance (LLCR)	10 milliohms maximum initial. 20 milliohms maximum final.	EIA-364-23. Subject mated contacts assembled in housing to 10 milliamperes and 20 millivolts maximum open circuit voltage. See Figure 4.
Insulation Resistance	1000 MΩ minimum initial. 500 MΩ minimum final.	EIA-364-21. Impressed voltage 500 V DC. Test between adjacent circuits, between The surface of housing and contact of mated connectors.
Dielectric Withstanding Voltage	2.2k VAC for 1 minute hold with no creeping discharge nor flashover shall occur. 5.0 milliamperes maximum leakage current.	EIA-364-20, Condition I. Test between adjacent circuits, between the surface of housing and contact of mated connectors.
Temperature Rise vs. Current	30°C maximum temperature rise.	EIA-364-70, Method 1. With DC. Measure temperature rising by energized current. Subject measurement must do at the place Of no influence from convection of air. And contacts assembled in housing all of circuits. Stabilize at a single current level until 3 readings at 5 minutes intervals are within 1°C. The thermocouple attached see Figure 4.
<b>Mechanical</b>		
Sinusoidal Vibration	No discontinuities of 1 microsecond or longer duration. Check LLCR before and after shock test. See 3.4.	EIA-364-28, Test Condition I. Subject mated specimens to 10 to 55 to 10Hz traversed in 1 minute with 1.52 mm maximum total excursion. Two hours in each of 3 mutually perpendicular planes. 100 mA applied. Mounting: See Fig 6

Test Description	Requirement	Procedure
Mechanical Shock	No discontinuities of 1 microsecond or longer duration. Check LLCR before and after shock test. See 3.4.	EIA-364-27. Accelerated Velocity : 490 m/2 (50G) Waveform : Half sine curve Duration : 11 m sec. Velocity Change : 3.4 m/s Number of Drops : 3 drops each to normal and reversed directions of X.Y and Z axes, totally 18 drops. Mounting:See Fig 5
Durability	Check connector mating/unmating force after Durability test. See 3.4	EIA-364-9. Mate and unmate specimens for 25 cycles at a maximum rate of 500 cycles per hour.
Connector Mating Force	Initial & After 25 Cycles 9.8×Pos N Max. 1.0×Pos kg Max.	EIA-364-13. Measure force necessary to mate specimens with latch disengaged. Operation Speed : 100 mm/min.
Connector Unmating Force	Initial & After 25 Cycles 1.47×Pos N Max. 0.15×Pos kg Max.	EIA-364-13, Method A. Measure force necessary to mate specimens with latch disengaged. Operation Speed : 100 mm/min.
TPA locking force	19.6N (2 kgf) minimum.	EIA-364-98. Measure double lock plate locking force strength at a maximum rate of 100 mm per minute.
Connector Locking Strength	29.4N (3.0 kgf) minimum.	EIA-364-98. Measure connector locking strength. Operation Speed : 100 mm/min.
Contact Mating Force	Initial & After 25 Cycles. 9.8N (1kgf) maximum per Contact.	EIA 364-9 Measured by gauge tab (see Fig.6) Operation Speed : 100 mm/min.
Contact unmating Force	Initial: 0.34N (35gf) minimum per Contact. After 25 Cycle: 0.245N (25gf) minimum per Contact.	EIA 364-9 Measured by gauge tab (see Fig.6) Operation Speed : 100 mm/min.
Contact Insertion Force	8.82N (0.9kgf) maximum per Contact	EIA-364-5 Measure the force required to insert contact into housing. Operation Speed : 100 mm/min.
Contact Retention Force	39.2N (4Kgf) Minimum per Contact	EIA-364-29 Apply an axial pull-off load to crimped wire. Use the wire of AWG #16 or AWG #18. Operation Speed: 100 mm/min.
Post Retention Force	29.4N (3.0 kgf) Min.	EIA-364-29 Measure post retention force. Operation Speed : 100 mm/min.

Test Description	Requirement		Procedure
Crimp Tensile Strength	<b>Wire Size (AWG)</b>	<b>Crimp Tensile (minimum) (N)</b>	EIA-364-8 Operation Speed: 100 mm/min Apply an axial pull-off load to crimped wire of contact secured on the tester. Subject take insulation barrel away.
	24	29.4	
	22	49.0	
	20	58.8	
	18	68.6	
	16	78.4	
<b>Environmental</b>			
Thermal Shock	Check LLCR before and after shock test. See 3.4.		EIA-364-32, Test Condition VII. Subject mated specimens to 25 cycles between -55 and 105°C with 30 minutes dwells at temperature extremes and 5 minutes transition between temperatures. The measurement is held after being left indoor for 3 hours.
Humidity/temperature Cycling	Check LLCR, Dielectric withstanding voltage and Insulation resistance after shock test. See 3.4.		EIA-364-31, Method III. Subject specimens to 10 cycles (10 days) between 25 and 65°C at 90 to 95% RH, Cold shock -10°C (not ) performed. The measurement is held after being left indoor for 3 hours.
Temperature Life (Heat aging)	Check LLCR before and after shock test. See 3.4.		EIA-364-17, Method A, Test Condition 4, Test Time Condition C. Subject mated specimens to 105±2°C for 96 hours. The measurement is held after being left indoor for 3 hours.
Salt Spray	Check LLCR before and after shock test. See 3.4. No corrosion influence performance.		EIA-364-26. Subject mated specimens to 5±1% salt concentration for 48 hours. The measurement is held after being left indoor for 3 hours.
Hydrogen Sulfide	Check LLCR before and after shock test. See 3.4.		Subject mated specimens to 3 ± 1 ppm H <sub>2</sub> S gas concentration maintained at 40 ± 2°C for 96 hours.
Ammonia	Check LLCR before and after shock test. See 3.4.		Subject mated specimens in atmosphere that rated 25 mL/L of 3% NH <sub>3</sub> for 7 hours.
Resistance to Cold	Check LLCR before and after shock test. See 3.4.		EIA-364-59 Mated connectors, -40±2°C, 96 hours
Solderability	Wet Solder Coverage :90 % Min.		TEC-109-11-12-1 Solder Temperature: 245 ± 5°C. Immersion Duration: 3 ± 0.5 seconds.

Test Description	Requirement	Procedure
Resistance to Soldering Heat	No physical damage shall occur.	TEC-109-202 Method B Test connector on PCB. Solder Temperature : $265\pm 5^{\circ}\text{C}$ Immersion Duration : $10 +2/-0$ sec. In case of manual soldering iron, apply it as $360\pm 10^{\circ}\text{C}$ for $3\pm 5^{\circ}\text{C}$ seconds without forcing pressure to affect the time of contact.
Glow Wire Test $750^{\circ}\text{C}$	Perform visual check and take picture after the test.	IEC 60695-2-11 and IEC 60335-1 No flame or $\text{Te-Ti} < 2\text{s}$ . Temperature: $750^{\circ}\text{C}$ . Duration of glow tip application $T_a$ : 30s.

**Figure 3**



**NOTE**

*Shall meet visual requirements, show no physical damage, and meet requirements of additional tests as specified in the Product Qualification and Requalification Test Sequence shown in Figure 3 & 4.*

3.5. Product Qualification and Requalification Test Sequence

TEST OR EXAMINATION	TEST GROUP (a)																		
	1	2	3	4	5	6	7	8	9	10	11	12	13	14	15	16	17	18	19
	TEST SEQUENCE (b)																		
Initial examination of product	1	1	1	1	1	1	1	1	1	1	1	1	1	1	1	1	1	1	1
LLCR	3,6		2,5	2,4	1		2	2,4,6			2,4			2,4	2,4	2,4	2,4		
Dielectric withstanding Voltage		3,7	7									4							
Insulation resistance		2,6	6									3							
Temperature rise vs. current							3												
Sinusoidal vibration								3											
Mechanical shock								5											
Durability	5												4						
Connector Mating force	2,7																		
Connector Unmating force	4,8																		
Crimping strength										2									
TPA locking force										2									
Post retention force					2														
Connector locking strength											5								
Contact insertion force												2							
Contact retention force												5							
Contact mating force													2						
Contact unmating force													5						
Glow wire test							2												
Thermal shock		4		3															
Humidity/temperature cycling		5	3																
Temperature life(Heat Aging)											3								
Salt spray														3					
Hydrogen sulfide															3				
Ammonia																3			
Resistance to Cold																	3		
Solderability																			2
Resistance to soldering heat																			2
Final examination of product	9	8	4	5	3	3	4	7	3	3	6	6	4	5	5	5	5	3	3

Figure 4



**NOTE**

(a) See paragraph 4.2.

(b) Numbers indicate sequence in which tests are performed.

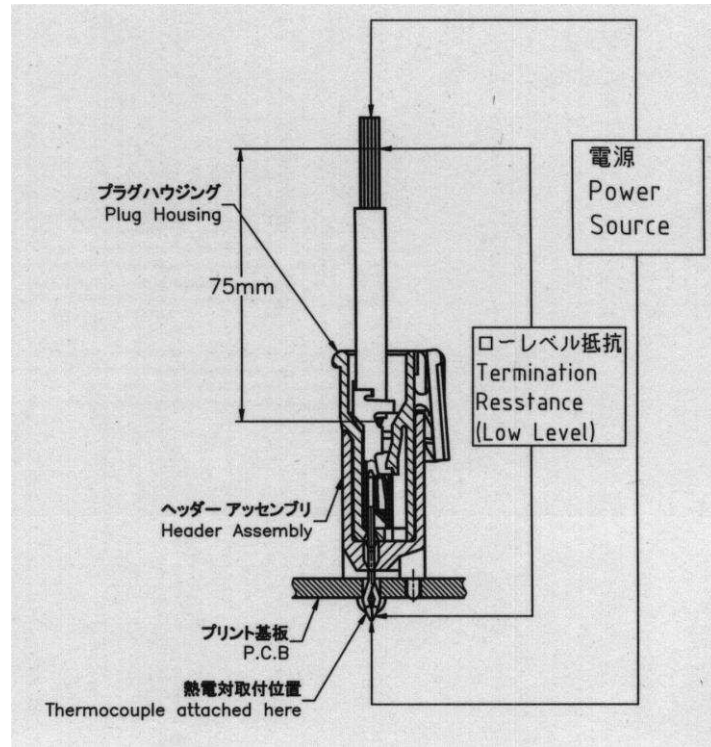

Figure 5 LLCR Measurement Points (Subtract Wire Bulk) and Temperature Rise Measurement Points

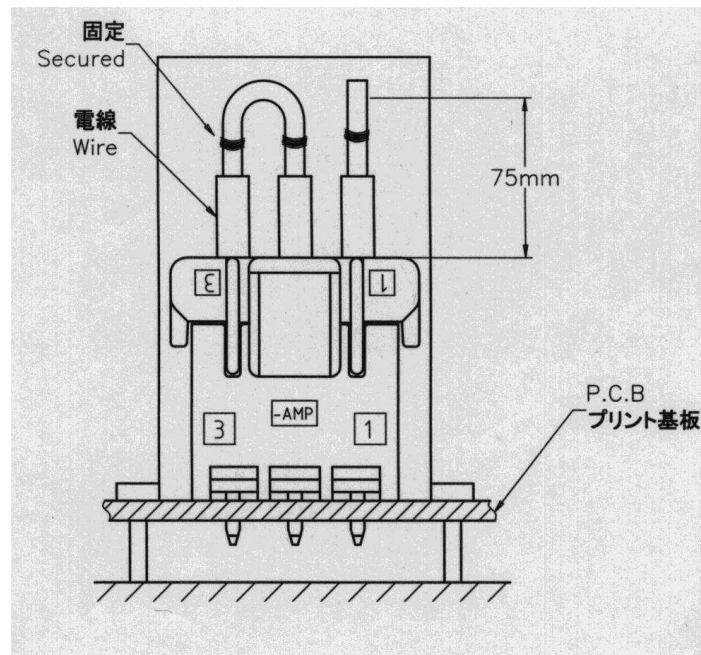
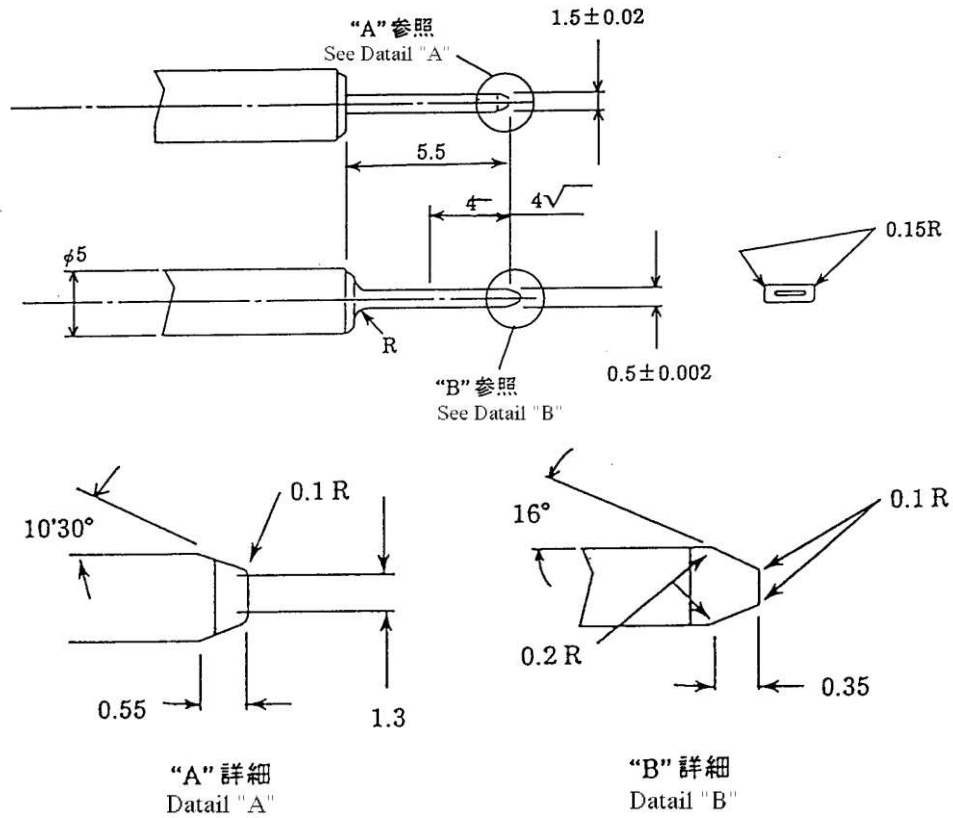

Figure 6 Vibration and Shock



**Figure 7** Gage Design for Contact Mating/Unmating Force Tests

## 3.6. Part Number List

Description	Part Number	Remark
Receptacle Contact(L)	X-1376347-X	AWG #20 ~ #16
Receptacle Contact(M)	X-1376348-X	AWG #24 ~ #20
Plug Housing	X-1376388-X	2P(Single row)
	X-1376389-X	3P(Single row)
	X-1376390-X	4P(Single row)
	X-1376391-X	6P(Single row)
	X-1376392-X	4P(Double row)
	X-1376393-X	6P(Double row)
Header Assembly	X-1376382-X	2P(Single row)
	X-1376383-X	3P(Single row)
	X-1376384-X	4P(Single row)
	X-1376385-X	6P(Single row)
	X-1376386-X	4P(Double row)
	X-1376387-X	6P(Double row)
Double Lock Plate	X-1376394-X	2P(for 2P Single row and 4P double row)
	X-1376395-X	3P(for 3P Single row and 6P double row)
	X-1376396-X	4P(only for 4P Single row)
	X-1376397-X	6P(only for 6P Single row)

**Figure 8**

**4. QUALITY ASSURANCE PROVISIONS**

4.1. Test Conditions

Unless otherwise specified, all the tests shall be performed in any combination of the following test conditions shown in Figure 7.

Temperature	15°C – 35°C
Relative Humidity	45% – 75%
Atmospheric Pressure	86.6 – 106.6 kPa

**Figure 9**

4.2. Qualification Testing

A. Specimen Selection

Specimens shall be prepared in accordance with applicable instruction sheets and shall be selected at random from current production.

B. Test Sequence

Qualification inspection shall be verified by testing specimens as specified in Figure 3 and **4Error! Reference source not found..**

4.3. Requalification Testing

If changes significantly affecting form, fit or function are made to the product or manufacturing process, product assurance shall coordinate requalification testing, consisting of all or part of the original testing sequence as determined by development/product, quality and reliability engineering.

4.4. Acceptance

Acceptance is based on verification that the product meets the requirements in Figure 2. Failures attributed to equipment, test setup or operator deficiencies shall not disqualify the product. If product failure occurs, corrective action shall be taken and specimens resubmitted for qualification. Testing to confirm corrective action is required before resubmittal.

4.5. Quality Conformance Inspection

The applicable quality inspection plan shall specify the sampling acceptable quality level to be used. Dimensional and functional requirements shall be in accordance with the applicable product drawing and this specification.