

Crimping Next Generation Grace Inertia Connector 2.5

新优雅系列 2.5 节距连接器 压接规格

1. Applicable Product Part Number

适用产品

Description 描述	Part No. 料号	Wire Size 适用线型 (mm ²)	Insulation Diameter 绝缘外径 (mm)	Remark 备注
Next Generation Grace Inertia Connector 2.5 Receptacle Contact 新优雅系列 2.5节距连接器 端子	1971795-1	(AWG 22#~28#) 0.079~0.38	φ 1.08~φ 1.5	Tin Plate Type 镀锡
	2232557-1			
	2232557-2 2232557-3			

2. Crimping Requirement

压接规格

NO.	Check Item 项目	Specified Requirements 规格值	NO.	Check Item 项目	Specified Requirements 规格值
①	Wire Stripping Length 剥线长度	2mm ± 0.3	⑥	Twisting 扭弯角度	3° Max
②	Cut-Off Tab Length 切断长度	0.25mm Max	⑦	Rolling 卷摆角度	5° Max
③	Rear Bellmouth Length 后喇叭口长度	0.13~0.50mm	⑧	Wire-End Length 线端伸出长度	0.1~0.65mm
④	Bend – Up 上翘角度	3° Max	⑨	Flash 压接凸边	0.2mm Max.
⑤	Bend – Down 下翘角度	3° Max	⑩	Wire to Insu.Jog 绝缘压接断差	0.35mm Min.

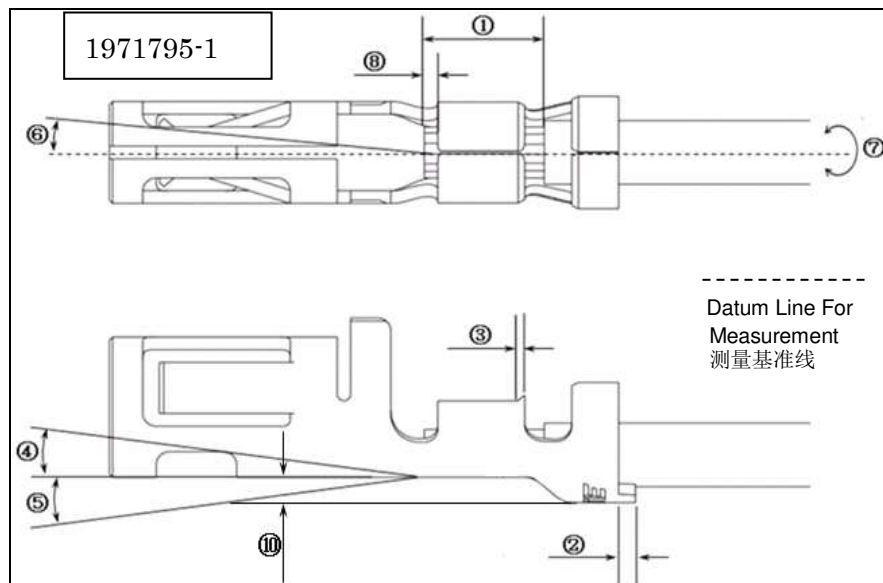

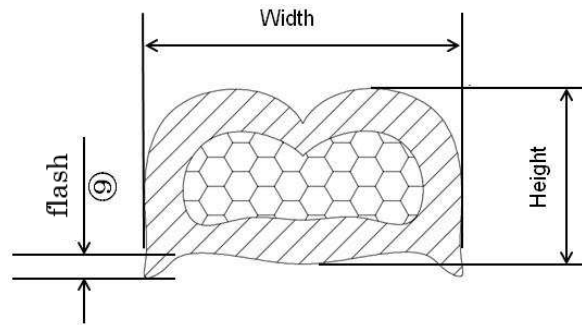
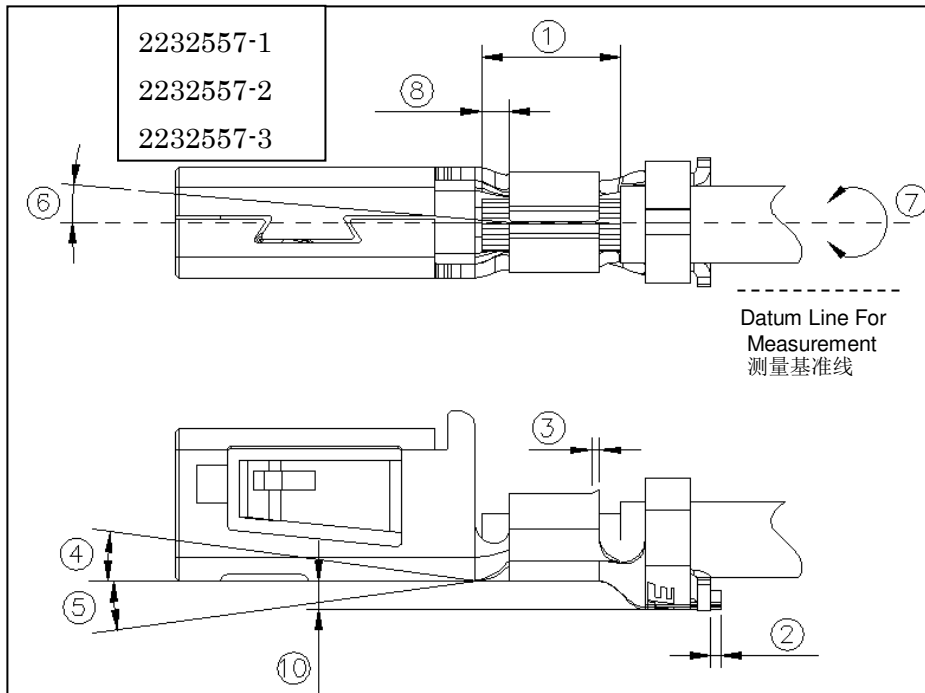

3. Crimping Data

压接参数

3.1 Applicator

自动工具

Contact Part No. (Strip) 端子料号 (带料)	Applicator No. 工具编号	Wire size 线型		Insulation Stripping Length 绝缘层剥线长度 (mm)	Wire barrel Crimp 线芯部分		Insulation Barrel width 绝缘部分压接宽度	Finished Insulation Diameter 卷缘压接完成直径 (mm)	Crimp Tensile Strength 压接拉伸强度 (N) (min.)
		No. of Conductors 导线数目	mm ² (AWG) 截面积		Width 宽度 (mm)	Crimp Height 压接高度 (mm)			
1971795-1	X-2151948-X	1	0.079 (Φ0.12/7) (#28)	2.0±0.3	1.16 (Ref) "F" shape* (Fs 型压接)	0.64±0.03	1.45 "F" shape* (F 型压接)	Φ1.08~Φ1.5	9.8
			0.12~0.15 (#26)			0.67±0.03			19.6
			0.21~0.23 (#24)			0.73±0.03			29.4
2232557-1	2836559-X		0.31~0.38 (#22)			0.80±0.03	1.45 "OV" shape		49
2232557-2									

SS

1.1 Hand Tool

手动工具

Contact Part No. (Strip) 端子料号 (带料)	Hand tool No 工具编号	Wire Size 线型		Insulation Stripping Length 绝缘层剥线长度 (mm)	Wire Barrel Crimp 线芯部分		Insulation Barrel Width 绝缘部分压接宽度	Finished Insulation Diameter 绝缘压接完成直径 (mm)	Crimp Tensile Strength 压接拉伸强度 (N) (Min)
		No. of Conductors 导线数目	mm ² (AWG) 截面积		Width 宽度 (mm)	Crimp Height 压接高度 (mm)			
1971795-1 loose piece part number	NA	1	0.079 (Φ0.12/7) (#28)	2.0±0.3	1.16 (Ref)	0.59~0.69	1.45 "F" shape* (F 型压接)	Φ1.08~Φ1.5	9.8
			0.12~0.15 (#26)						19.6
			0.21~0.23 (#24)			29.4			
2232557-3 (loose piece part number)	2439196-1		0.31~0.38 (#22)			0.69~0.79	1.45 "OV" shape		49

* F shape: follow below diagram to do the crimp for shape "F":

F 型压接: 请参照下图所示形状进行 F 型压接:

